

Reduced wiring system
PROFIBUS-DP Compatible GW unit



Operation Manual

EX510-GPR1



SMC Corporation

URL <http://www.smcworld.com>

Table of Contents

Thank you for purchasing the SMC reduced wiring system EX510 series.

Please read this manual carefully before operating this product and make sure you understand this product, its capabilities and limitations.

Please keep this manual handy for future reference.

OPERATOR

- This operation manual has been written for those who have knowledge of machinery and apparatuses that use reduced wiring units and have full knowledge of assembly, operation and maintenance of such equipment.
- Please read this operation manual carefully and understand it before assembling, operating or providing maintenance service to the actuator.

Phone

AUSTRIA / (43) 2262-62 280	ITALY / (39) 02-92711
BELGIUM / (32) 3-355 1464	NETHERLANDS / (31) 20-531 8888
CZECH REP. / (420) 5-414 24611	NORWAY / (47) 67 12 90 20
DENMARK / (45) 70 25 29 00	POLAND / (48) 22-548 50 85
FINLAND / (358) 9-859 580	PORTUGAL / (351) 2 610 89 22
FRANCE / (33) 1-64 76 1000	SPAIN / (34) 945-18 4100
GERMANY / (49) 6103 4020	SWEDEN / (46) 8-603 0700
GREECE / (30) 1- 342 6076	SWITZERLAND / (41) 52-396 3131
HUNGARY / (36) 1-371 1343	TURKEY / (90) 212 221 1512
IRELAND / (353) 1-403 9000	UNITED KINGDOM / (44) 1908-56 3888

Safety Instructions	2
Product Summary	6
Name of Parts / Accessories	7
Dimensions	8
Settings	8
Specifications	10
Wiring	11
Display/ Switch Setting	17
Troubleshooting	21

Safety Instructions

The reduced wiring system and this manual contain essential information to protect users and others from possible injury and property damage and to ensure correct handling.

Please check that you fully understand the definition of the following messages (signs) before going on to read the text, and always follow the instructions.

Please read the operation manual of related apparatus and understand it before operating the actuator.

IMPORTANT MESSAGES

Read this manual and follow its instructions. Signal words such as WARNING, CAUTION and NOTE, will be followed by important safety information that must be carefully reviewed.

WARNING

Indicates a potentially hazardous situation which could result in death or serious injury if you do not follow instructions.

CAUTION

Indicates a potentially hazardous situation which if not avoided, may result in minor injury or moderate injury.

NOTE

Gives you helpful information.

WARNING

Do not disassemble, retrofit (including change of printed circuit board) or repair.

An injury or failure can result.

Do not operate beyond specification range.

Fire, malfunction or switch damage can result.
Please use it after confirming the specification.

Do not use the product in the environment with possible presence of flammable, explosive or corrosive gas to prevent fire, explosion or corrosion.

Note the reduced wiring system does not have explosion proof construction.

These instructions must be followed when using the product in an interlocking circuit:

- Provide double interlocking by another system such as mechanical protection
 - Check the product regularly to ensure proper operation
- Otherwise malfunction can cause an accident.

These instructions must be followed while in maintenance:

- Turn off the power supply
 - Stop the supplied air, exhaust the residual pressure and verify the release of air before performing maintenance
- Otherwise it can cause injury.

CAUTION

Execute a proper performance inspection after completing the maintenance check.

Please stop driving for abnormality as neither the product nor work normally.

There is a possibility that safety cannot be secured due to the unintentional malfunction.

Provide grounding for improving safety and noise resistance of reduced wiring system.

Individual grounding is provided to the product closely with short distance.

NOTE

The direct-current power supply to combine should be UL authorization power supply.

1. Limited voltage current circuit in accordance with UL508

A circuit which power is supplied by the secondary coil of a transformer that meets the following conditions

- Maximum voltage(with no load): less than 30Vrms(42.4V peak)
- Maximum current:(1)less than 8A(including when short circuited)
(2)limited by circuit protector (such as fuse) with the following ratings

No load voltage (V peak)	Max. current rating (A)
0 to 20[V]	5.0
Above 20 to 30 [V]	100 / peak voltage

2. A circuit using max. 30 Vrms or less (42.4V peak), which power is supplied by Class-2 power supply unit in accordance with UL1310 or UL1585

Follow the instructions given below when handling your reduced wiring system. Or, it will have a risk of being damaged and operating failure.

- Operate reduced wiring system with the specified voltage.
- Reserve a space for maintenance.
- Do not remove labels.
- Do not drop, hit or apply excessive shock to the product.
- Follow the specified tightening torque.
- Do not bend or apply tensile force to cables, or apply force by placing heavy load on them.
- Connect wires and cables correctly.
- Do not connect wires while the power is on.
- Do not lay wires or cables with power line or high-voltage line in the same wiring route.

- Verify the insulation of wiring.
- Separate power line for solenoid valves from power line for Input and control unit.
- Take proper measurements against noise such as noise filter when the reduced wiring system is incorporated in equipment or devices.
- Select the proper type of protection according to the environment of operation.
- Take sufficient shielding measures when installing at a following place.
 - (1) A place where noise due to static electricity is generated
 - (2) A place where electric field strength is high
 - (3) A place where there is radioactive irradiation
 - (4) A place near power line
- Do not use the product nearby a place where electric surges are generated.
- Use reduced wiring system equipped with surge absorber when a surge-generating load such as a solenoid valve is driven directly.
- Prevent foreign matter such as remnant of wires from entering this product.
- Do not expose reduced wiring system to vibration and impact.
- Keep the specified ambient temperature range.
- Do not expose reduced wiring system to heat radiation from a heat source located nearby.
- Use a precision screwdriver with small flat blade when setting DIP switch.
- Perform maintenance and check regularly.
- Perform a proper functional check.
- Do not use the product with chemicals such as benzene and thinner.

Product Summary

System structure

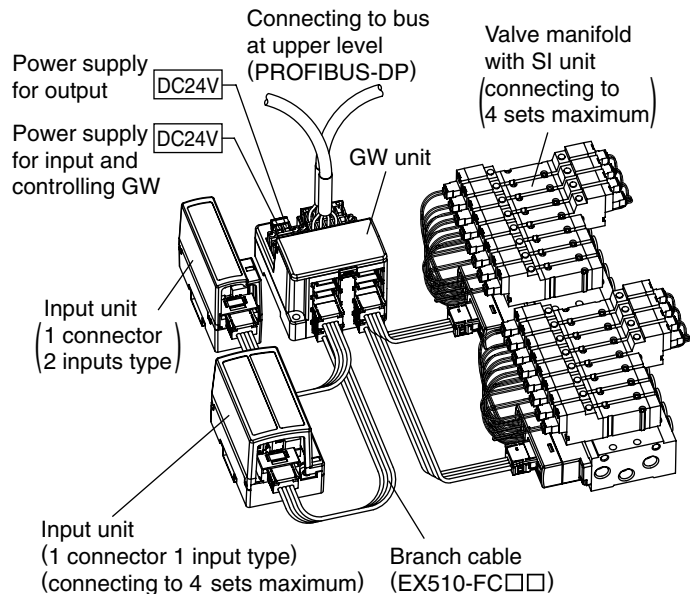

The system which realizes wiring saving and distributed installation by connecting to PROFIBUS-DP. The signal to PROFIBUS-DP is transmitted by GW unit, and the signal to input/output device which is installed discretely is collected by GW unit.

Name of Parts/ Accessories

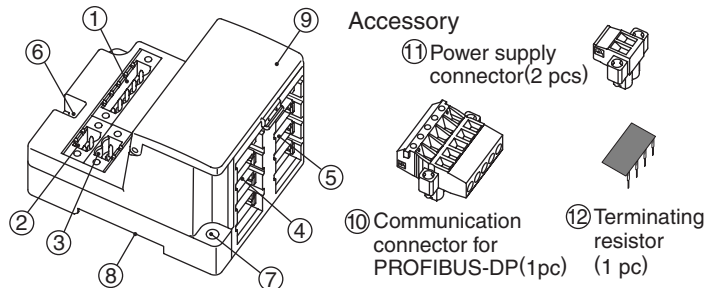

No.	Parts	Purpose
1	Communication socket (BUS)	Connect to PROFIBUS-DP line with a communication connector for PROFIBUS-DP (⑩). Connect a terminating resistor (⑫) to both end units of a transmission route*.
2	Power supply socket (PWR(V))	Supplying power for output instruments such as a solenoid valve with a power supply connector (⑪)*.
3	Power supply socket (PWR)	Supplying power for controlling GW and input instruments such as a sensor with a power supply connector (⑪)*.
4	GW unit side branch connector (for input)	Connecting an input unit etc. by using branch cables (EX510-FC□□).
5	GW unit side branch connector (for output)	Connecting SI unit (manifold valve) etc. by using branch cables (EX510-FC□□).
6	PE terminal	Used for grounding.
7	Mounting hole	Used when a unit is mounted with two M4 screws.
8	DIN rail mounting slot	Used when a unit is mounted to DIN rail.
9	Display/ setting switch area	Switch setting such as LED display in unit state, Address and I/O point.

*For wiring method, see "Wiring" in the "Operation manual".

Dimensions (in mm)

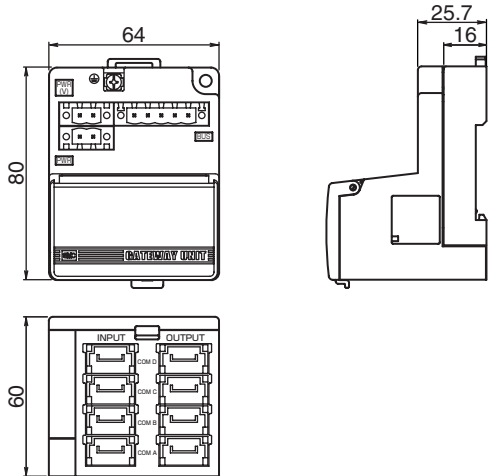

Settings

Mounted by screw

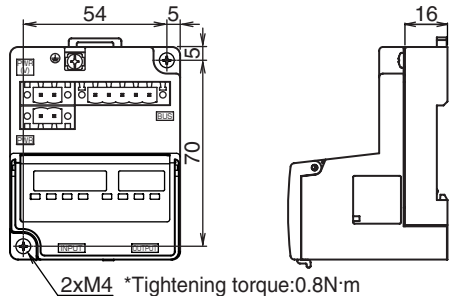

Perspective drawing
(tolerance ± 0.2)

Settings (continued)

Mounted on DIN rail

Put claw 1 at the body under DIN rail and push it upward. Push down claw 2 to the opposite rail until the claw clicks securely on to rail.

(Mounting procedure ① and ②)

For removing, lever up the DIN rail fixing plate at the body with a flat screwdriver, and remove it by tilting claw 2 side forward.

(Removal procedure ③ and ④)

Mounting

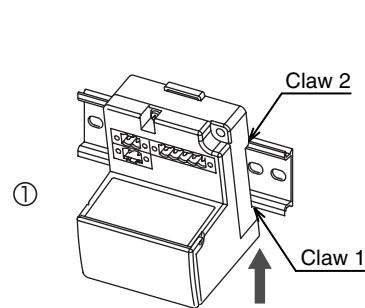

①

Removal

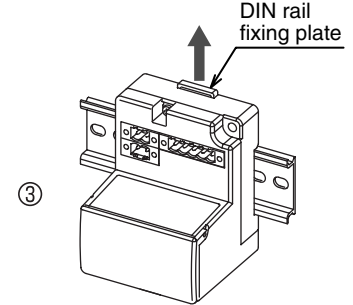

③

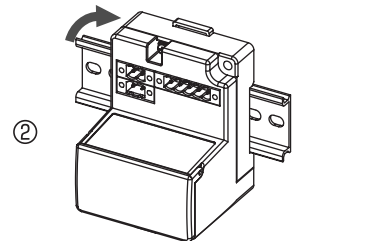

②

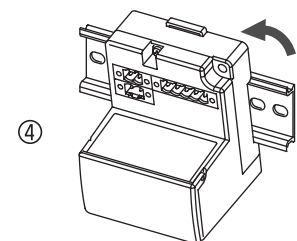

④

Specifications

Basic specifications

Rated voltage	24VDC
Range of power supply voltage	Power supply for input and controlling GW : 24VDC ±10% Power supply for output : 24VDC+10%/-5% (Warning for voltage drop is given at approx. 20V)
Rated current	Power supply for input and controlling GW : Max.4.1A (Inside GW unit: 0.1A, Input unit: 4A) Power supply for output:Max.6A
Input/ output point	Input point: Max. 64 / Output point: Max. 64 (Changeable by switch settings)

Upper level bus

Compatible system	PROFIBUS-DP V0
Bus Interface	EIA RS-485
Freeze function	Available
Synchronous function	Available
Address setting range	0 to 125
ID no.	140d HEX
Device data file	GSD file*

*This file is necessary for automatic device setting.

Communication speed [kbps]	9.6	19.2	45.45	93.75	187.5
Max. wiring length [m] *	1200				1000
Communication speed [kbps]	500	1500	3000	6000	12000
Max. wiring length [m] *	400	200	100		

*Max. wiring length differs depending on the specification of a cable.
The specification of wiring length is based on type A cable.

Lower level bus

Number of branches for input/ output	4 branches for input 4 branches for output
Communication type	Communication protocol: Dedicated for SMC Communication speed: 750kbps
Branch current for input	Max. 1A per branch
Branch current for output	Max. 1.5A per branch
Branch cable length	At 0.75A per branch : 20m or less At 1.0A per branch : 16m or less At 1.5A per branch : 10m or less

Wiring

Internal circuit

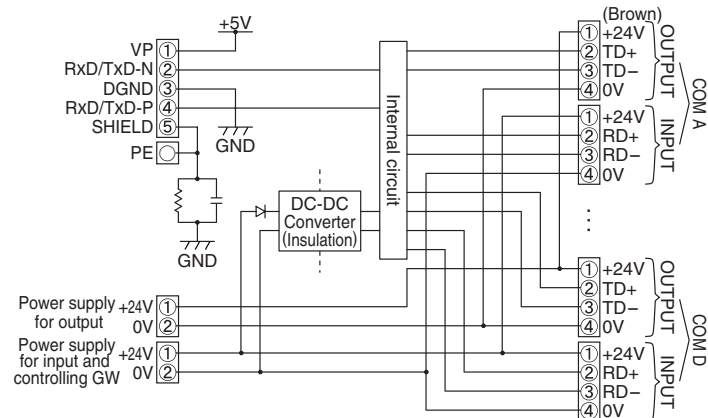

Branch wiring

The wiring between each unit should use branch cables, and be connected with branch connectors.
SI unit and Input unit have 2 branch connectors for each.

Pressure welding for branch connector

The method of pressure welding for branch connector is explained.

(1) Components

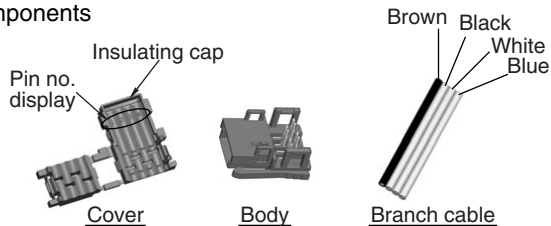

(2) Working procedure

① Set a branch cable to the cover.

- 1) Set the brown wire of the branch cable so that it comes to the pin no.1.
- 2) Meet the cable end to the insulating cap at the cover.
- 3) Fold the cover so that the branch cable can be put between the cover.
- 4) Fix the latch tip by inserting to a hole for fixing latch.

Note) Check the color of wire written on a branch connector and the color of branch cable are same.

② Fix to a body tentatively.

Fit 4 latches on a body to 4 ditches on the cover, and press them until the latch engages to the level 1.

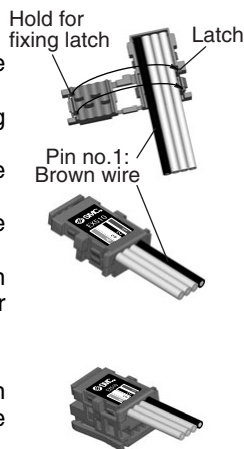

③ Press fitting

Press the cover to the body with plier etc.

④ Confirmation

It is completed with a check on 4 latches engaging.



Wiring of branch cables

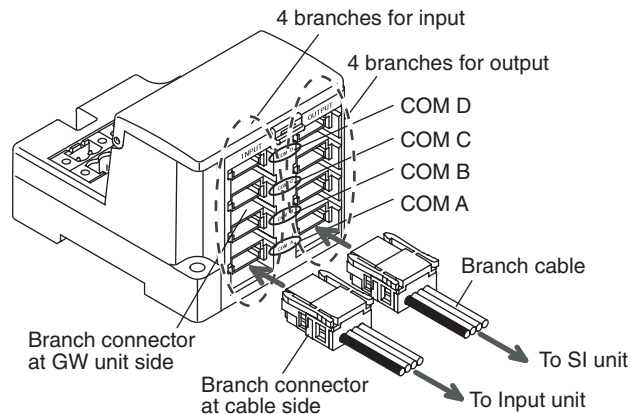

Insert branch connector on the table side from the bottom (COM A, B, C, D of branch connector of GW unit side).

Communication wiring

Connect PROFIBUS-DP dedicated cables to the communication connector for PROFIBUS-DP.

- (1) Make sure to connect the signal cables to designated pins (Refer to Drawing 1). And tighten the connector surely to 0.5 to 0.6 N·m tightening torque.

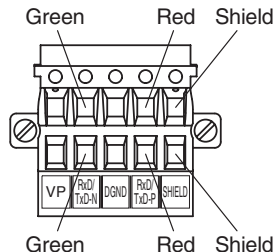

Drawing1

- (2) Make sure to connect a "terminating resistor" to the units at the both ends of the system (Refer to Drawing 2). For firmly tightening, give a torque of 0.5 to 0.6 N·m.

*The terminating resistor attached to this unit as an accessory is recommended.

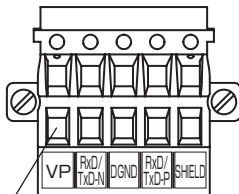

Connect the pin with VP mark on terminal resistance to VP of the communication connector.



Drawing2

The value of terminating resistor changes with cable specification. This value of terminating resistor is based on type A cable (Refer to Drawing 3).

Specification of type A cable

Impedance	135 to 165Ω
Capacitance between conductors	30 pF/m or less
Conductor resistance	110Ω/km or less
Cable diameter	0.64 mm or more
Conductor area	0.34 mm ² or more

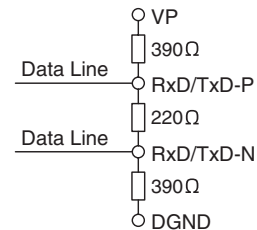

Drawing3

- (3) Refer to Drawing 4 about how to connect to the unit.

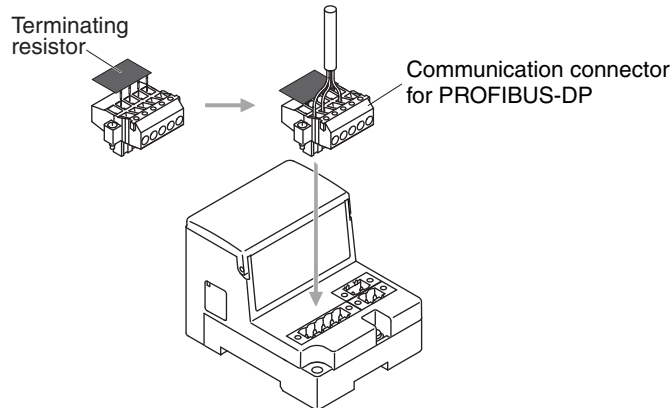

Drawing4

Power supply wiring

Connect power supply wiring to the two power supply 2pin connectors. Power supply structure consists of 2 systems, but it can be used with both single power supply and separate power supply.

Individual power supply for other units is not necessary. Make sure of connection with the designated pin. Tighten the connector securely to 0.5 to 0.6N·m tightening torque.

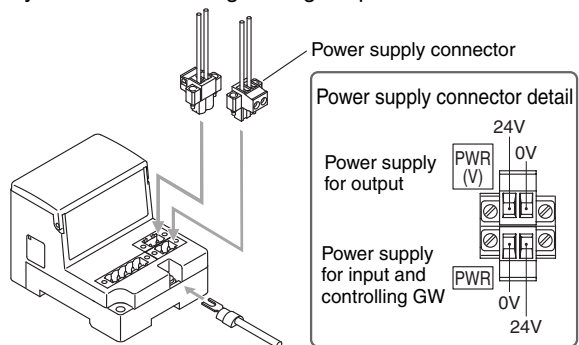

Note

A secure earth connection (Protection class 3) should be performed for PE terminal.

A. For separate power supply use

B. For single power supply use

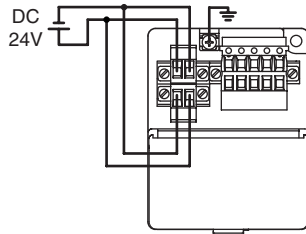
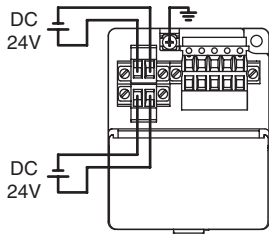

Display / Switch Setting

Setting for Display

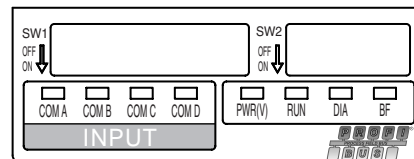

Display	Meaning
PWR (V)	The power for output is supplied with specified voltage: Lights up The power for output is not supplied with specified voltage: Goes off
RUN	Power supply for input and controlling GW is supplied: Lights up Power supply for input and controlling GW is not supplied: Goes off
DIA	With extension diagnosis information*1: Lights up Without extension diagnosis information: Goes off
BF	PROFIBUS-DP communication is abnormal: Lights up PROFIBUS-DP communication is normal: Goes off
COM A	COM A is receiving data: Lights up*2 COM A is having no data to receive: Goes off
COM B	COM B is receiving data: Lights up*2 COM B is having no data to receive: Goes off
COM C	COM C is receiving data: Lights up*2 COM C is having no data to receive: Goes off
COM D	COM D is receiving data: Lights up*2 COM D is having no data to receive: Goes off

*1: Refer to "Technical Specification" for the extension diagnosis information.

*2: It is lit when Input unit is connected and communicating normally. LED of COM A-D does not light up if the port is not set to be "used" by input point setting.

Switch setting

Make sure that switch setting is performed with power supply turned off.

The switch setting is mode available by opening a cover and using a flat driver.

Setting of Address, UNIT STATUS, HOLD/CLR, HW/SW mode (SW1)

These setting are done with SW1.

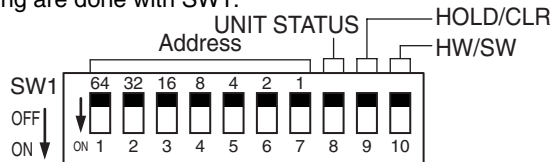

Address setting (switch No.1 to 7)

At the time of shipment from the plant, all settings are turned off and the address is set to 0. Make sure to set the address in the range of 0 to 125.

Address	64(No.1)	32(No.2)	16(No.3)	8(No.4)	4(No.5)	2(No.6)	1(No.7)
0	OFF	OFF	OFF	OFF	OFF	OFF	OFF
1	OFF	OFF	OFF	OFF	OFF	OFF	ON
2	OFF	OFF	OFF	OFF	OFF	ON	OFF
3	OFF	OFF	OFF	OFF	OFF	ON	ON
4	OFF	OFF	OFF	OFF	ON	OFF	OFF
:	:	:	:	:	:	:	:
24	OFF	OFF	ON	ON	OFF	OFF	OFF
25	OFF	OFF	ON	ON	OFF	OFF	ON
:	:	:	:	:	:	:	:
125	ON	ON	ON	ON	ON	OFF	ON
126	ON	ON	ON	ON	ON	ON	OFF
127	ON	ON	ON	ON	ON	ON	ON

*Setting of the address 126 and 127 are invalid.

UNIT STATUS setting (switch No. 8)

The setting is as follows.

The settings when shipped from plant is turned OFF, GW status information is not sent to master side as an input data.

UNIT STATUS	No.8	Function
OFF	OFF	GW status information isn't sent to master side as an input data.
ON	ON	GW status information is sent to master side as an input data.

*If the address setting is turned on, an input setting for PLC is required. Refer to "Technical Specification" for detail.

HOLD/CLR setting (switch No. 9)

The setting is as follows.

The settings when shipped from plant is turned OFF, set to CLR.

HOLD/CLR	No.9	Function
CLR	OFF	Output is cleared when a communication error occurs.
HOLD	ON	Output is held when a communication error occurs.

*HOLD/CLR setting is made available per one point by parameter setting. Refer to "Technical Specification" for detail.

HW/SW mode setting (switch No. 10)

The setting is as follows.

The setting when shipped from plant is turned OFF, set to HW mode.

Mode	No.10	Function
HW	OFF	Set Address with SW1 to 7.
SW	ON	Address are set by network. The setting when shipped from plant is 126. Note : SW1 to 7 are ignored.

Input/Output Setting (SW2)

Input/Output Setting is performed with SW2.

Number of input setting Number of output setting



Input setting (switch No.1 to 3), Output setting (switch No.4 to 6)

The setting is as follows. At the time of shipment from the plant, all settings are turned OFF, 64 Input/Output points.

No.1	No.2	No.3	Input point	COM A	COM B	COM C	COM D	
OFF	OFF	OFF	64	16	16	16	16	
OFF	OFF	ON	0	—	—	—	—	
OFF	ON	OFF	16	8	8	—	—	
OFF	ON	ON	24	8	8	8	—	
ON	OFF	OFF	32	8	8	8	8	
ON	OFF	ON	48	16	16	16	—	
ON	ON	OFF	Reserve					
ON	ON	ON						

No.4	No.5	No.6	Output point	COM A	COM B	COM C	COM D	
OFF	OFF	OFF	64	16	16	16	16	
OFF	OFF	ON	0	—	—	—	—	
OFF	ON	OFF	16	8	8	—	—	
OFF	ON	ON	24	8	8	8	—	
ON	OFF	OFF	32	8	8	8	8	
ON	OFF	ON	48	16	16	16	—	
ON	ON	OFF	Reserve					
ON	ON	ON						

*Input/Output points set at PLC must be consistent with the Input/Output points set at the GW unit.

Overall system

No.	Item	Remedy / Disposal
1	Solenoid valve is not working	<ul style="list-style-type: none"> •Check the power for output (24VDC) is supplied. •Check the branch cable is connected to SI unit. •Check the LED for power supply (PWR) and the LED for communication (COM) at SI unit are ON. •Ensure output branch current does not exceed the specification range.
2	Valve is not working as program directs	<ul style="list-style-type: none"> •Program it after checking the wiring specification of manifold block assembly.
3	Signals cannot be received even with a sensor	<ul style="list-style-type: none"> •Check the power for input and controlling GW (24VDC) is supplied. •Check the input unit indication LED is ON. •Ensure input branch current does not exceed the specification range.
4	LED of COM A-D is not LIT	<ul style="list-style-type: none"> •Check the connection of UNLIT COM port branch to input unit. •LED of unused COM port does not light up when an input unit is connected. Check the port is set to be "unused" by input point setting.
5	RUN LED goes off	<ul style="list-style-type: none"> •Check the power for input and controlling GW is supplied.
6	PWR(V) LED goes off	<ul style="list-style-type: none"> •Check the power for output (24VDC) is supplied. •Check the power supply voltage for output is above 20V. •Check the power for input and controlling GW (24VDC) is supplied.

PROFIBUS-DP compatible communication

No.	Item	Remedy / Disposal
1	BF LED lights up	<ul style="list-style-type: none">•Check the signal line from PLC is correctly connected.•Check the wiring and pin numbers.•Check the address setting is correct.•Check the connecting condition of the terminating resistor.•Check the number of input/output is set correctly.
2	DIA LED lights up	<ul style="list-style-type: none">•Check the power for output (24VDC) is powered at a specified voltage.•Check the power supply voltage for output is above 20V.•Check the input unit is connected after the input port.

*Refer to "Technical Specification" for detail of troubleshooting.