



Operation Manual

PRODUCT NAME

Refrigerated Air Dryer

MODEL / Series

IDU3E-10(-C,K,L,M,R,S,T)	IDU3E-20(-C,K,L,M,R,T)
IDU4E-10(-C,K,L,M,R,S,T)	IDU4E-20(-C,K,L,M,R,T)
IDU6E-10(-C,K,L,M,R,S,T)	IDU6E-20(-C,K,L,M,R,T)
IDU3E-23(-C,K,L,R,T,V)	
IDU4E-23(-C,K,L,R,T,V)	
IDU6E-23(-C,K,L,R,T,V)	

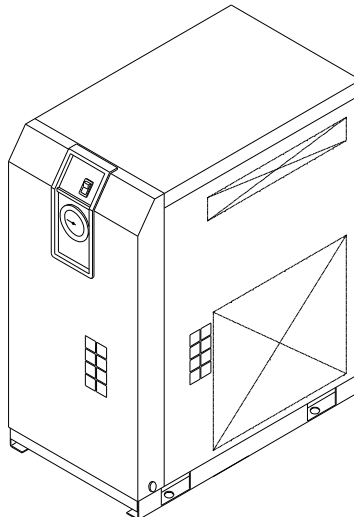

This manual is intended to explain the installation and operation of the product. Only those who have thorough understanding of the fundamental operating procedure or have basic knowledge and skills of handling industrial products are qualified to perform installation and operation.

Please read this manual prior of using the air dryer.
Keep the manual readily available for reference.

SMC Corporation

To Customers

Thanks for purchasing SMC Refrigerated Air Dryer.

This operation manual must be read and understood throughoutly before handling. It provides all essential information for maximizing product operating efficiency, as well as, for safe and longer life span operation.

For safety operation of SMC Refrigerated Air Dryer, read thoroughly and follow stated safety instructions, as well as regulation stated within ISO 4414^{*1} & JIS B 8370^{*2}.

*1) ISO 4414: Pneumatic fluid power – General rules and safety requirements for systems and their components

*2) JIS B 8370: Pneumatic fluid power – General rules relating to systems

This manual explains about installation and operation of the product. Only those who have thorough understanding of the fundamental operating procedure or have basic knowledge and skills of handling industrial product for the installation and operation of the product are qualified to perform installation and operation.

The contents of the operation manual and the other documents attached to the product cannot become a part of the contract clause or cannot change and modify existing agreements, promises, and relationship.

Any statements contained in the operation manual cannot be newly guaranteed and modify existing guarantee certificate.

You are not allowed to copy any part of this operation manual for usage of third person without informing it to us beforehand.

<p>Caution: Please understand that the contents of this operation manual are subject to changed without previous notice.</p>
--



Table of Contents

Chapter i	Safety Instructions	
i - 1	Warning: Before Using Air Dryer	i - 1
i - 1 - 1	Meanings of signs: Danger, Warning, Caution	i - 1
i - 2	Danger Classifications / Position of Danger warning label	i - 3
i - 2 - 1	Danger Classifications	i - 3
i - 2 - 2	Danger of Electricity	i - 4
i - 2 - 3	Danger of High Heat	i - 4
i - 2 - 4	Danger of Rotor	i - 4
i - 2 - 5	Danger of Compressed Air Circuit	i - 4
i - 2 - 6	Positions of Danger Warning Label	i - 5
i - 2 - 7	Danger of Refrigerant	i - 6
i - 2 - 8	Cautions about Usage	i - 7
i - 2 - 9	Other Label	i - 7
i - 3	Disposal	i - 8
i - 4	Limited warranty and Disclaimer / Compliance Requirements	i - 9
Chapter 1	Parts Name and Functions	
1 - 1	Parts Names and Functions	1 - 1
Chapter 2	Transportation / Installation	
2 - 1	Transportation	2 - 1
2 - 2	Installation	2 - 2
2 - 2 - 1	Location	2 - 2
2 - 2 - 2	Anchorage	2 - 2
2 - 2 - 3	Air piping	2 - 3
2 - 2 - 4	Drain Tube	2 - 3
2 - 2 - 5	Electric wiring	2 - 4
2 - 3	Cautions about Reinstallation	2 - 6
Chapter 3	Operation / Shutdown	
3 - 1	Check points before operation	3 - 1
3 - 2	Operation	3 - 1
3 - 3	Shutdown	3 - 2
3 - 4	Cautions about restart	3 - 2
3 - 5	Check points before restart	3 - 2
3 - 6	Precautions for long-term non-operation	3 - 2
Chapter 4	Maintenance	
4 - 1	Daily inspection	4 - 1
4 - 2	Periodical Maintenance	4 - 1
4 - 2 - 1	Cleaning of ventilation grille (suction grille)	4 - 1
4 - 2 - 2	Service parts	4 - 1
4 - 2 - 3	Cleaning of auto drain strainer	4 - 2
4 - 2 - 4	Replacement of bowl assembly	4 - 2
Chapter 5	Troubleshooting	5 - 1
5 - 1	Cause and countermeasure of errors	5 - 1

Chapter 6	References	
6 - 1	Specifications	6 - 1
6 - 2	Refrigerant with GWP reference	6 - 3
6 - 3	Dimensions.....	6 - 4
6 - 4	Electrical Circuit.....	6 - 5
6 - 5	Compressed Air and Refrigerant Circuit / Operation Principles	6 - 6
Chapter 7	Specification for Option C	
7 - 1	Specifications	7 - 1
7 - 2	Precautions for the installation and handling of the product	7 - 1
Chapter 8	Specification for Option K	
8 - 1	Safety instructions	8 - 1
8 - 2	Specifications	8 - 1
Chapter 9	Specification for Option L	
9 - 1	Safety instructions	9 - 1
9 - 2	Specification	9 - 1
9 - 3	Installation of heavy duty auto drain	9 - 2
9 - 4	Maintenance.....	9 - 2
Chapter 10	Specification for Option M	
10 - 1	Safety instructions	10 - 1
10 - 2	Specifications	10 - 2
10 - 3	Installation of motor type auto drain	10 - 3
10 - 4	Electric circuit.....	10 - 3
Chapter 11	Specification for Option R	
11 - 1	Safety instructions	11 - 1
11 - 2	Specifications	11 - 1
11 - 3	Power supply connection procedure	11 - 2
11 - 4	Cautions for handling the GFCI	11 - 3
11 - 5	Electric circuit.....	11 - 3
Chapter 12	Specification for Option S	
12 - 1	Safety instructions	12 - 1
12 - 2	Specifications	12 - 1
12 - 3	Electric circuit.....	12 - 1
Chapter 13	Specification for Option T	
13 - 1	Safety instructions	13 - 1
13 - 2	Specifications	13 - 1
13 - 3	Remote operation	13 - 1
13 - 4	How to connect the power and signal cable	13 - 2
13 - 5	How to re-start the operation	13 - 2
13 - 6	Electric circuit.....	13 - 3
Chapter 14	Specification for Option V	
14 - 1	Safety instructions	14 - 1
14 - 2	Specifications	14 - 2
14 - 3	How to perform maintenance.....	14 - 2
14 - 4	Electric circuit.....	14 - 3
Chapter 14	Service Record	
15 - 1	Service Record	15 - 1



Safety Instructions



Before use, read and comprehend important cautionary notification well on this operation manual.

i-1 Warning: Before Using Air Dryer

In this chapter, the stated contents are especially about safety way to use the product. for customer.

An Air Dryer is installed on the downstream of the air compressor to remove moisture. We, manufacturer, cannot take any responsibility if you use it for any other purpose.

An Air Dryer works with high voltage and has some parts that gets hot or rotates during operation. Ask vendor if you need component replacement and servicing.

Not only people handle the air dryer but every people who perform maintenance on or do works related to it should read safety instructions on this operation manual before handling.

This operation manual is not a general safety manual which is practiced by safety training representatives. People who handle this product or work around it need to take training to comprehend inherent risks of it and master measures for safety.

It is usually responsible for super visor to follow the safety instructions, but each operator or maintenance representative should do daily operations on their own head.

Operators and maintenance representatives should take the safety of working place and work environment into account.

It is necessary to think of the safety of working place and work environment for each task

Take enough safety training before the operation training. It is very dangerous to do operation training without any safety training. Operation training must be paid attention to its safety.

i – 1 – 1 Meaning of Signs: Danger, Warning, Caution

These safety instructions are intended to prevent hazardous situation and/or product damage.

These instructions indicate the level of potential hazard by signs “**Danger**”, “**Warning**” or “**Caution**”. Contents with these signs state about important instructions concerning safety.

Confirm where those signs are, and read and comprehend notices and cautionary notices well before handling.

“**Danger**”, “**Warning**” or “**Caution**” is the order of importance (Danger>Warning>Caution).

Followings are the meanings of those signs.



Danger

Statements with the “Danger” sign explain about conditions in which there is a possible result of serious injury or loss of life if someone handles wrongly during operation or maintenance and did not follow the procedure to avoid danger.



Warning

Statements with the “Danger” sign explain about possibilities that can result in serious injury or loss of life if someone handle wrongly during operation or maintenance and did not follow the procedure to avoid danger.





Caution

Statements with the “Danger” sign explain about possibilities that can result in injury or product damage if someone handles wrongly during operation or maintenance and did not follow the procedure to avoid danger.

i-2 Danger Classifications / Position of Danger Warning Label

To protect operator's safety, we group danger into some types uniquely and attached labels indicating those types. Confirm the contents of the danger types and positions of the labels before operation.

	Warning
<p>No one but professionals should operate an air dryer.</p> <p>Transportation, installation, and maintenance involve risks. These should be done by someone who have enough knowledge and experience about this product and incidental devices.</p> <p>No one but our service personnel or qualified person should open the cover panel of this product.</p>	

	Warning
<p>Should any problem occur, address it according to statements on this manual.</p> <ul style="list-style-type: none"> • Identify problems according to "Chapter 5 Troubleshooting." • Ask repair and maintenance. 	

	Warning
<p>The product should not be operated in the event of any problems.</p> <p>When the product gets out of order, shutdown it immediatery, and contact our service person or qualified person.</p>	

i – 2 – 1 Danger Classifications

Specific danger classification of this product is as follows.

Danger of Electricity

Since this product runs at high voltage, there is the danger of electric shock. So, we display a symbol with indications, "**Danger**", "**Warning**" or "**Caution**," on the product and this manual.



Danger of Heat

Since this product becomes hot while driving, there is the danger of burn injury. So, we display a symbol with indications, "**Danger**", "**Warning**" or "**Caution**," on the product and this manual.



Danger of Rotor

Since this product has parts that rotate while driving, there is the danger of catching your fingers in or injury. So, we display a symbol with indications, "**Danger**", "**Warning**" or "**Caution**," on the product and this manual.



i – 2 – 2 Danger of Electricity

Inside of this product, there is power-supplying section with high voltage separated by the cover panel. Do not operate the product without the cover panel.

No one but trained qualified person should operate or inspect in the power transmission sections.

**Warning**

Read with caution and pay attention to the notations on danger warning labels.

Do not remove or rub danger warning labels.

Confirm the positions of danger warning labels.

i – 2 – 3 Danger of High Heat**Warning**

Since this product has parts that become hot during operation, there is the danger of burn injury resulting from contact with them. What is more, there is also the danger of burn injury due to remaining heat after the power supply is cut. Therefore, wait until the temperature of hot parts become 50°C and below.

i – 2 – 4 Danger of Rotor**Warning**

Since this product has parts that rotate during operation, there is the danger of burn injury resulting from contact with them. Though sometimes those parts can temporarily stop the rotation, they will rotate again, and so do not work with them while driving.

i – 2 – 5 Danger of Compressed Air Circuit**Warning**

Before replacing or cleaning parts, be sure to bleed compressed air remain inside of the product until the gauge indicates “0”. If you do not do this air-bleeding, there would be the great danger of unexpected accident, such as shooting out of parts when they are being unscrewed.

i - 2 - 6 Positions of Danger Warning Label

⚠	Warning
<p>Read with caution and pay attention to the notations of danger warning labels.</p> <p>Do not remove or rub danger warning labels.</p> <p>Confirm the positions of danger warning labels.</p>	

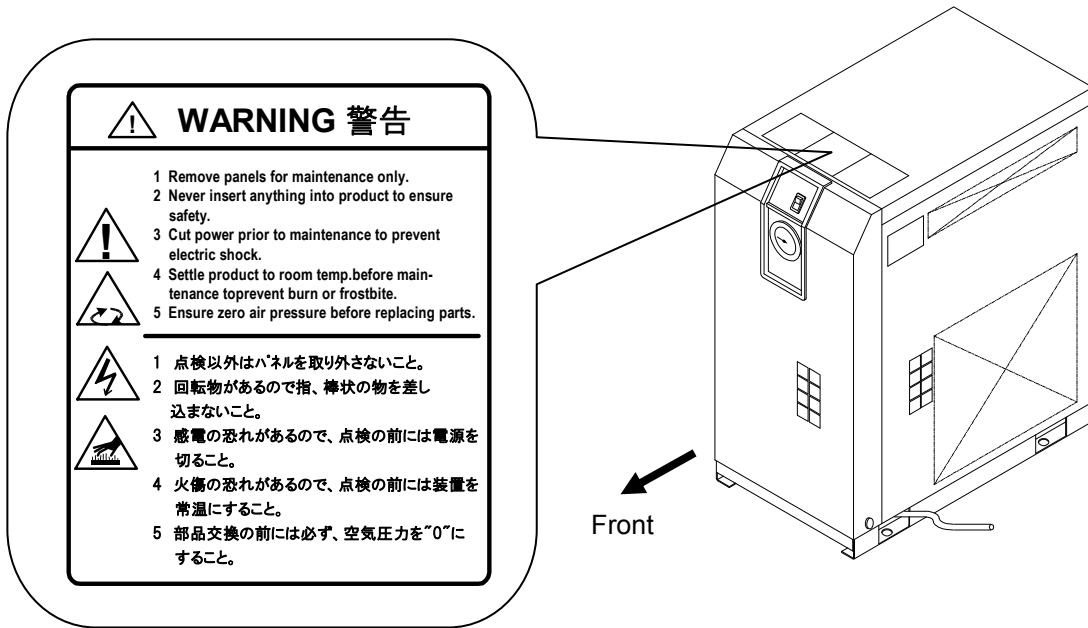

i – 2 – 7 Danger of Refrigerant

Caution

This product uses Fluorocarbon (HFC) as a refrigerant.

This product is specified by “Class 1 Fluorocarbon Collection and Destruction Law in Japan.” It is strictly forbidden to emit Fluorocarbon to the atmosphere. Before you repair this product, you should collect the refrigerant with “Refrigerant collector.” Then, ask a destruction agency to dispose of collected refrigerant. No one but someone have enough knowledge and experience about the product and incidental device should do the collection of the refrigerant. No one but service person or qualified person should remove the cover panel of the product.

The quantity and the sort of the Fluorocarbon are mentioned on the specification label that are explained on Page i – 8.

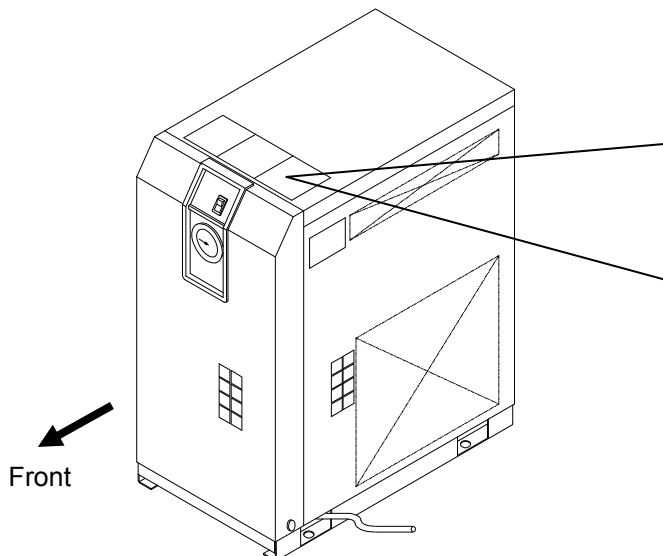

Act for Rationalized Use and Proper Management of Fluorocarbons
フロン排出抑制法 第一種特定製品

This product uses Fluorocarbon (HFC) as a refrigerant.

- 1 It is prohibited to release fluorocarbons without permission.
- 2 For the disposal of the product, fluorocarbons must first be collected.
- 3 The number and quantity of the refrigerant of the fluorocarbon used for this product is shown on the product label.
- 4 GWP values of the calculated leakage of fluorocarbons to be reported are as in the table below.

この製品には冷媒として、フロン類 (HFC) が使用されています。

- 1 フロン類をみだりに大気中に放出することは禁じられています。
- 2 この製品を廃棄する場合には、フロン類の回収が必要です。
- 3 本製品に使用している、フロン類の冷媒番号、量は、型式銘板に記載されています。
- 4 算定漏えい量の報告に使用する、フロン類の GWP 値は以下になります。

Refrigerant No.	R134a	R407C	R410A	R404A
GWP values	1430	1770	2090	3920

i - 2 - 8 Cautions about Usage

 Warning
<p>Read with caution and pay attention to the notations on danger warning labels.</p> <p>Do not remove or rub danger warning labels.</p> <p>Confirm the positions of danger warning labels.</p>

CAUTION 注意

1 Read manual before operation.
2 Ensure ventilation and maintenance space.
3 Keep water away from the product.
4 Secure In / Out connector with spanner during piping.
5 Wait 3 minutes before restart.
6 Ensure Running Condition / Evaporating Temp. in green zone.

1 ご使用前に必ず取扱説明書を読んでください。
2 通風、メンテナンススペースを確保してください。
3 雨や水滴がかからないようにしてください。
4 IN/OUTポートをスパナで固定して配管してください。
5 再起動は運転停止3分後に行ってください。
6 RUNNING CONDITION・蒸発温度計はグリーン帯で使用してください。

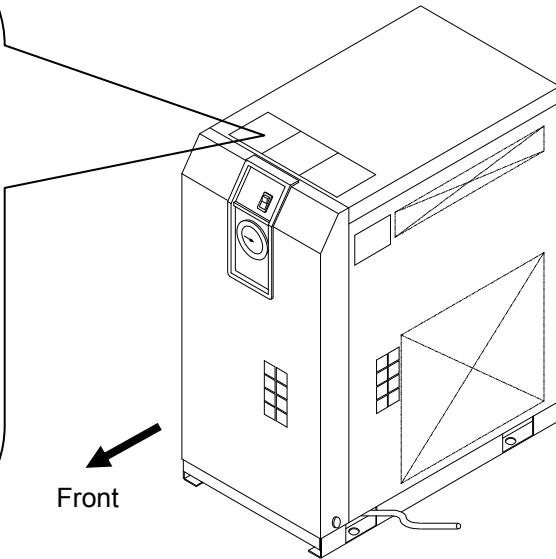

i - 2 - 9 Other Label

Confirm the model, contents of specifications on the label.

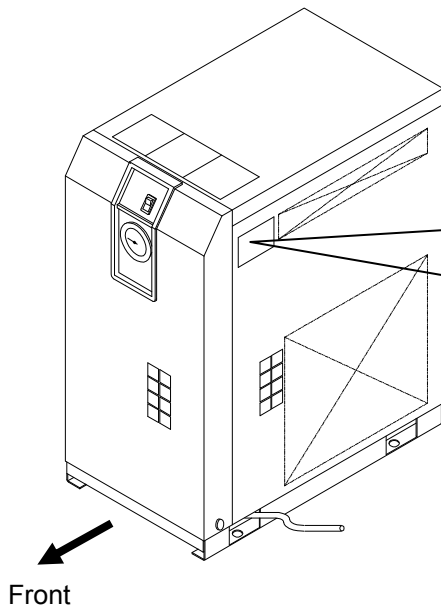

IDF * * * E - * * *

-

VOLTAGE

RUNNING CURRENT

REFRIGERANT

WEIGHT

MAX. PRESS.

SERIAL No.

4-14-1, Sotokanda, Chiyoda-ku,
Tokyo 101-0021, Japan



1550515060001

MADE IN
G

Specification Label

i-3 Disposal

When you dispose of the product, you should collect the refrigerant and the refrigerant oil enclosed in the refrigerant circuit.



Caution

A sort of Fluorocarbon (HFC) is used for this product as refrigerant.

This product is specified by "Class1 Fluorocarbon Collection Destruction Law in Japan." It is strictly forbidden by the law to emit the refrigerant to the atmosphere. Before you repair this product, you should collect the refrigerant with "Refrigerant collector." Then, ask a destruction agency to dispose of collected refrigerant.

No one but someone who has enough knowledge and experience about the product and incidental devices should do the collection of the refrigerant.

No one but a service person or qualified person should remove the cover panel of the product.

The quantity and the sort of the Fluorocarbon are printed on the specification label.



Caution

Dispose of the refrigerant and refrigerant oil according to the bylaw or regulation of local government.

Do not dispose of refrigerant oil together with domestic garbage. And do not burn it in unauthorized incinerators.

No one but someone who has enough knowledge and experience about the product and incidental devices should do the collection of the refrigerant oil.

No one but a service person or qualified person should remove the cover panel of the product.

If there are something not clear, please contact our service office.

i-4 Limited warranty and Disclaimer / Compliance Requirements

The product used subject to the following “Limited warranty and Disclaimer” and “Compliance Requirements. Read and accept them before using the product.

Limited warranty and Disclaimer

1. The warranty period of the product is 1 year in service or 1.5 years after the product is delivered. Also, the product may have specified durability, running distance or replacement parts. Please consult your nearest sales branch.
2. For any failure or damage reported within the warranty period which is clearly our responsibility, a replacement product or necessary parts will be provided.
This limited warranty applies only to our product independently, and not to any other damage incurred due to the failure of the product.
3. Prior to using SMC products, please read and understand the warranty terms and disclaimers noted in the specified catalog for the particular products.

Compliance Requirements

1. The use of SMC products with production equipment for the manufacture of weapons of mass destruction (WMD) or other weapon is strictly prohibited.
2. The exports of SMC products or technology from one country to another are governed by the relevant security laws and regulation of the countries involved in the transaction. Prior to the shipment of a SMC product of a SMC product to another country, assure that all local rules governing that export are known and followed.

Caution

**The Product is provided use in manufacturing industries.
The product herein described is basically provided for peaceful use in manufacturing industries.
If considering using the product in other industries, consult SMC beforehand and exchange specifications or a contact if necessary.
If anything is unclear, contact your nearest sales branch.**



Caution

**SMC products are not intended for use as instruments for legal metrology.
Measurement instruments that SMC manufactures or sells have not been qualified by type approval tests relevant to the metrology (measurement) laws of each country. Therefore, SMC products cannot be used for business or certification ordained by the metrology (measurement) laws of each country.**

1 Parts Name and Functions

1-1 Parts Name and Functions

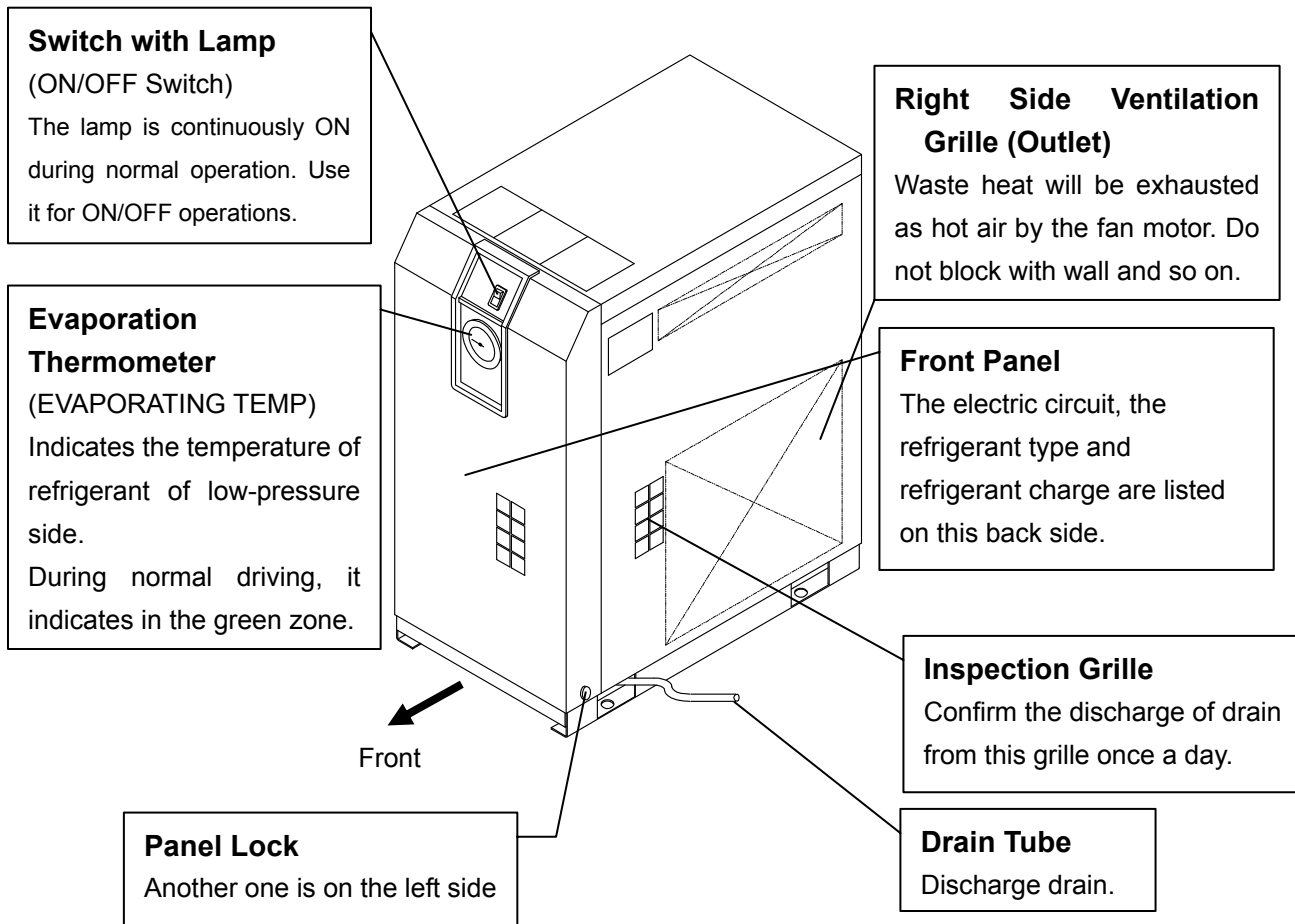
• IDU3E to 6E



View with Front Panel removed

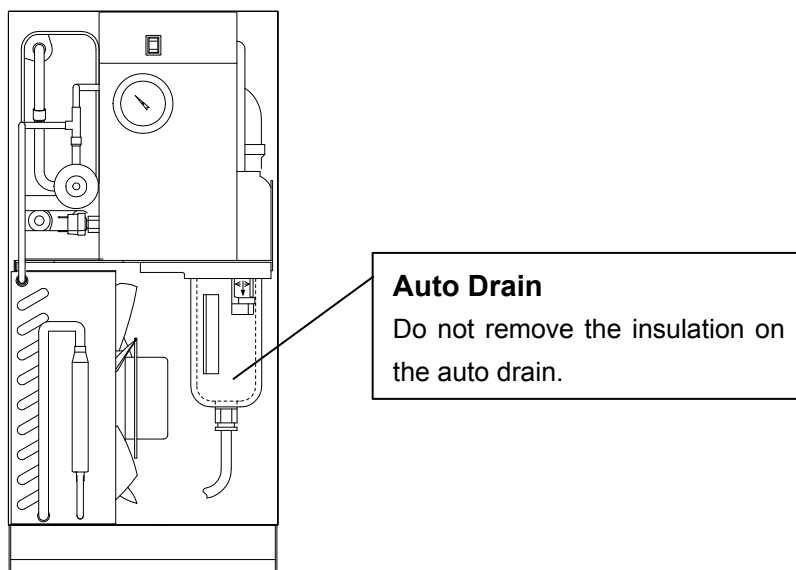

• IDU3E to 6E-10 (100V AC specification)

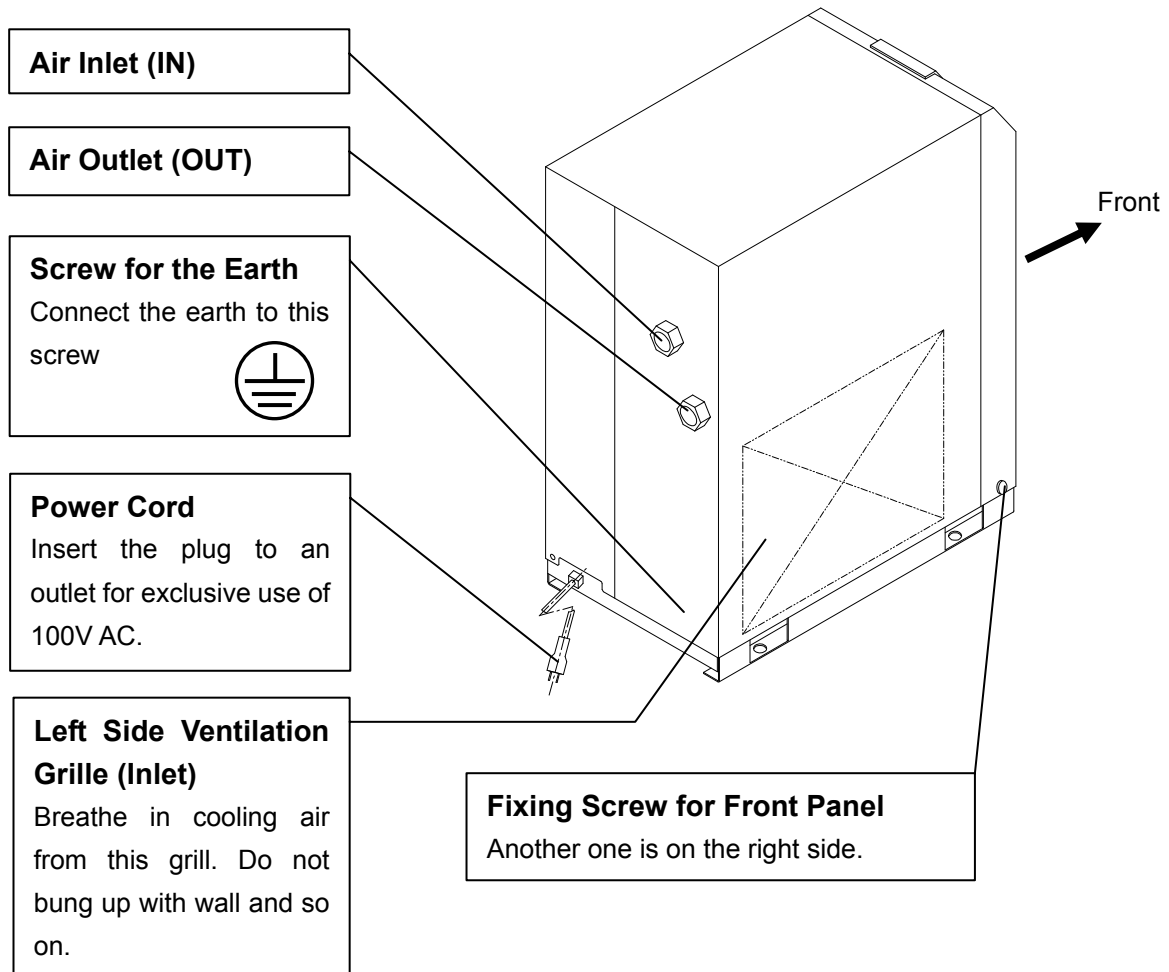

• IDU3E to 6E-20/23 (200V/230V AC specification)

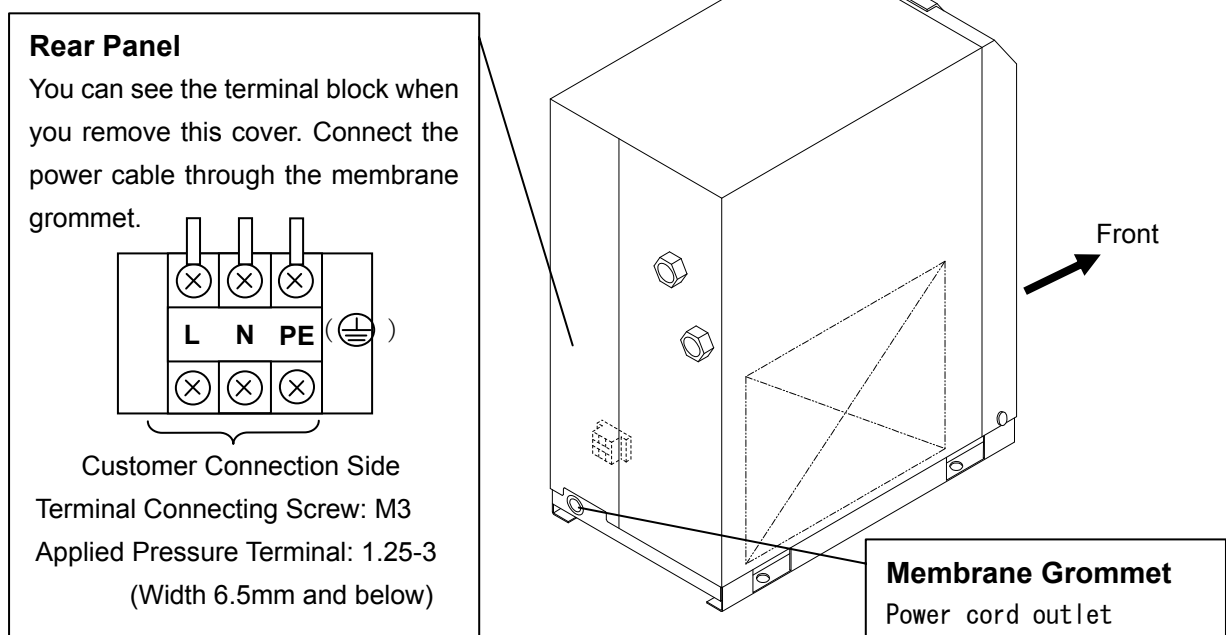

2**Transportation / Installation**** Warning**

Use the product in the right way. During Installation, operation, maintenance, and check, you should be careful in keeping the safety of human body.

 Caution

Transportation, installation, and maintenance including dangerous work must be done by a personnel who has enough knowledge and experience about the product and the system.

2-1 Transportation

When you transport the product, you should follow these instructions below.

- You should uplift the product from the base surface with careful attention to prevent falling sideways and drop.
- Do not bring the product lying sideways. If you lay it sideways, it will be broken.
 - Do not hang up the product.
 - Do not transport the product with any part such as an air filter mounted on the fittings at the air inlet or outlet port of the product. If it is unavoidable to transport the product with such a part mounted, support the part with a bracket to prevent the product from being affected by vibration during transportation.

 Warning

Those instructions above must be followed because the product is so heavy that it carries a great risk to transport.

IDU3E~6E are 23 to 28kg and 46kg or more. They must be transported by more than 2 person or transport it by forklift.

2-2 Installation

2-2-1 Location

The product should not be used or stored in the circumstances as follows.

Those circumstances will cause not only malfunction but also failures.

- Environment where the product is exposed to rainwater, moisture vapor, salty water, oil and so on.
- Locations where dust or particles are.
- Locations where inflammable or explosive gas are.
- Locations where corrosive gas, solvent, combustible gas are.
- Locations that receive direct sunlight or where radiant heat is generated.
- Locations where ambient temperature is beyond following range:
 - On-stream: 2 to 40°C
 - Storage: 0 to 50°C (when there is no drain water inside of the piping)
- Locations where temperature changes rapidly.
- Locations where strong electromagnetic noise is generated (locations where electromagnetic field, strong magnetic field, surge is generated)
- Circumstances where static electricity is produced or discharged through the body of the product.
- Locations where strong high frequency wave is generated.
- Locations where danger of thunder is apparent.
- Locations by loading on vehicles, marine vessels, and so on.
- Locations whose altitude is higher than 2,000 meters.
- Circumstances where strong vibration or impact are transmitted.
- Circumstances where too much force and weight are put on the body of the product that causes it to deform.
- Circumstances where enough spaces cannot be taken to do maintenance (in the plant where the product is operated).
 - Spaces needed for maintenance
 - Front : 600 mm
 - Rear : 600 mm
 - Top : 600 mm
 - Right : 600 mm
 - Left : 600 mm
- Locations the ventilation grille of the product can be blocked.
- Place where rejection style air of air compressor or other driers (hot wind) is inhaled.
- Condition which has sudden pressure/flow rate changes.

Warning

Do not use and store in environment having compressed air or ambient atmosphere which includes the following substances. It could result in failure of the product and damage of components, which leads to injury.

- Corrosive gas, Organic solvent, Chemicals

2-2-2 Anchorage

- The air dryer should be installed on a vibration-free, stable, horizontal flat surface.
- Refer to "Chapter6 6-3 Dimensions" for the dimensions.
- Fix by bolts to prevent falling down. The bolts can be prepared separately as an accessory.

Model No.	Name	Quantity	Applicable Model
IDF-AB500	Anchor bolt set	1(4pcs/1set)	IDU3E to ID6E

2-2-3 Air piping

- Connection to the inlet and outlet of compressed air should be made removable by using union and so on.
- Pressing the hexagonal fitting with screw wrench and so on, connect the air piping fittings to the body.
- When mounting any part such as an air filter on the fitting at the compressed air inlet or outlet port, support the part to prevent excessive force from being applied to the product
- Be careful not to let the vibration of the air compressor transmit.
- If the temperature of compressed air on the inlet side is higher than 50°C, place an aftercooler after the air compressor. Or, make the temperature of the place where the air compressor is installed lower than 50°C.
- If the air supply makes high pressure fluctuation (pulsation), take any countermeasures such as installing air tank.
- Flash the piping sufficiently in order to avoid any foreign substances such as dust, sealing tape, liquid gasket, etc. when piping before piping connection. Foreign substances in the piping can cause cooling failure or drainage failure.
- Use pipes and fittings that have enough endurance against the operating pressure and temperature. And connect it firmly to prevent air leakage.
- Provide bypass piping to make it possible to do maintenance without stopping the air compressor.

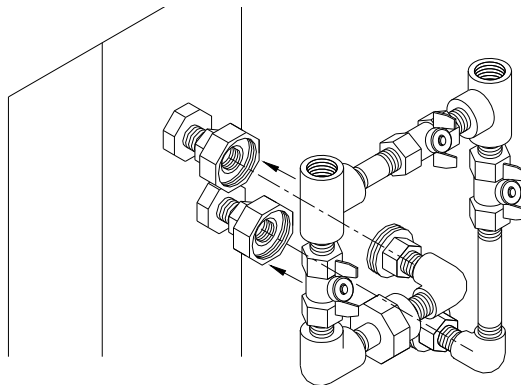

We recommend the bypass piping sets that we are selling separately as accessories.

Model No.	Name	Q.t	Applicable Model
IDF-BP305	Bypass piping sets	1	IDU3E
IDF-BP306		1	IDU4E
IDF-BP307		1	IDU6E

2-2-4 Drain Tube

- A polyurethane tube of 10mm external diameter is attached to the drain tube. The outlet end of the tube is released to atmosphere. And let drain flow through the tube into a scupper and so on.
- Using the pressure of the compressed air, drain will be discharged periodically. Fix the outlet end of the tube so as not to swing during discharge.
- Prevent the drain tube from riser piping.
- Prevent the drain tube from being folded or flatted. Since the drain tube is coming from the bottom of the body, be careful to avoid the body from stomping over the tube during installation.

2-2-5 Electric Wiring

Warning

No one but qualified person should do the wiring work.

- Before wiring, you must cut the power off for safety. Do not work under any energized conditions.
- Supply power from a stable place, which is free from the effect of surge.
- Ensure that a Ground Fault Circuit Interrupter(GFCI) with appropriate capacity for earth leakage and load is used in the power supply of the product to prevent electrical shock and burnout of the compressor motor. See “6-1 List of specifications” for details.
- Supply power for the product should meet the specifications.
- The product should be grounded for safety.
- Do not connect the earth to a water pipe, a gas pipe, or a lightning rod.
- Do not plug too many leads into a single socket. That causes exothermic heat or fire.
- Do not convert the wiring to use.
- In European countries, a circuit breaker that meets the IEC standard should be used for the supply power.

There are two methods depends on model (specified power).

IDU3E-10 ~ 6E-10 (100V specified)

- Insert the power plug into an outlet of 100V AC.
Install a Ground Fault Circuit Interrupter(GFCI) to the power supply (sensitivity of leak current 30mA and rated current 10A). (Prepare by yourself)
- Do not extend the power cable using power strip and so on. That causes decrease of the voltage and the product cannot be operated.

IDU3E-20 ~ 6E-20 (200V specified), IDU3E-23 ~ 6E-23 (230V specified)

- Remove the terminal block cover or the rear cover in the rear of the product, and connect the power (200V AC) to the terminal block.
- Install a Ground Fault Circuit Interrupter(GFCI) to the power supply (sensitivity of leak current 30mA and rated current 10A). (Prepare by yourself)

Specification of power cable

Prepare following power cable.

Power cable: 1.25mm²(16AWG), Three-cores (including the earth), External diameter: about 8 ~ 12mm

Additional length of about 0.1m is needed to wire inside of the product.

Length of the power cable

The length of the power cable should extend less than 30m from the product.

Connecting to the power supply

Connect the power cable and the earth to the terminal block. M3 screw is used for the connection part. Make sure to use round crimped terminal.

Applicable crimped terminal: 1.25-3 (Width: 6.5mm and below)

Wiring procedure

- Remove the terminal block cover or the rear panel.
- Insert the cord through the membrane grommet and connect it to the terminal block (refer to the label on the terminal block). M3 screw tightening torque: 0.6~1Nm.
During wiring work, do not touch other sections except terminal block.
- Attach the cover or the rear panel as it were.

Length of the power cable

The length of the power cable should extend less than 30m from the product.

Connecting to the power supply

Connect the power cable and the earth to the terminal block. M3 screw is used for the connection part. Make sure to use round crimped terminal.

Applicable crimped terminal: 1.25-3 (Width: 6.5mm and below)

2-3 Cautions about Reinstallation



Caution

No one but someone who has enough knowledge about the product and incidental devices should reinstall in another place. And following instructions must be executed.

If you move the product and reinstall it into another place after some operations (including trial running), instructions that are not only following ones but also all of those in the chapter 2 should be followed.

Disassembly of the power cable

Cut off the power source when you disassemble the power cable.



Warning

**No one but qualified personnel should do the electric wiring.
Cut off the power supply for safety before the wiring. Do not work under energized condition.**

Disassembly of the air piping



Warning

**No one but qualified personnel should do the air piping.
Separate the compressor from the product for safety before removing the piping. Do not remove any piping when there is remaining compressed air pressure inside of it.**

Remove the seal tape completely after detaching the piping. Remained tape will cause imperfect cooling and failure by entering into the body of the product.

Residual compressed air pressure release procedure

- Even while the dryer is removed, only when compressed air is needed, open the bypass piping valve.
- Close the compressed air inlet and outlet valve.
- Make sure the ball valve located next to the auto drain opened.
- Open the auto drain residual pressure release valve to release air pressure inside the product. Refer to the figure at right.

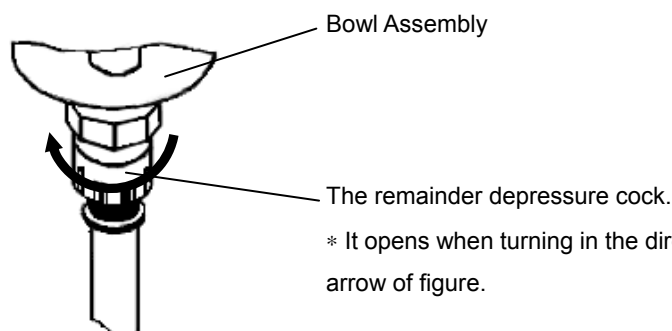

* It opens when turning in the direction of the arrow of figure.

3**Operation / Shutdown****Caution**

No one but someone who has enough knowledge and experience about the product and incidental devices should operate or shut down the product.

3-1 Check points before operation

Before a trial running, check following points.

- **Installed Condition**
By visual inspection check that the product is installed horizontally.
Make sure the product is fixed enough with anchor bolts.
Do not place heavy obstacles on the product and add unreasonable loading by piping and so on.
- **Wiring Connections**
Power cord, and the earth should be connected firmly.
- **Drain Tube**
Drain tube should be connected correctly.
- **Air Piping**
Make sure the piping for compressed air is connected correctly. Those valves of IN / Out side and bypass piping of the product and of the bypass piping should be completely fasten.
- **Ball valve**
Make sure the ball valve located next to the auto drain opened.

3-2 Operation

Start operation according to the procedure below.

- Turn on the breaker of the main power supply. Then, turn on the illuminated switch.
- The lamp will light up. Few minutes later, the cooling fan will rotate and hot air will be exhausted from the ventilation grille.
Place of the ventilation grille: IDU3E ~ 6E: Right Side Ventilation Grille
- Open the IN / Out side valve slowly. Make sure the bypass valve is completely closed. Make sure the bypass valve is completely closed. Confirm there is no air leakage.
- Depending on the condition of compressed air or ambient temperature, the cooling fan sometimes alternates between rotation and stop at the beginning. Then, the refrigerator will go into continuous run and the pointer of the evaporation thermometer will indicate in the green zone. If the pointer of the evaporation thermometer indicates higher than the green zone, refer to "Chapter5 Troubleshooting."
- After a while from the start of flowing the compressed air, drain will be discharged from the drain tube automatically.
- Keep the condition of continuous run to use.

 **Caution**

- Avoid frequent On/Off operation, which can cause troubles.
- The auto drain used for the product has a structure that closes the valve with air pressure higher than 0.15MPa. Therefore, until the pressure increase, air will be emitted from the drain outlet at the beginning of opening the IN side valve. Keep in mind that sometime the pressure cannot increase enough with air compressor that has low discharge flow rate.
- Avoid using this product under the condition which has sudden pressure/flow rate changes. Otherwise, drain (condensed water) may flow out to the secondary piping.

3-3 Shutdown

- Turn off the illuminated switch.
- The lamp will go out and then, the operation will be stopped. Depending on the condition of operation, hot air continues to be emitted from the ventilation grille by the cooling fan for a while after turning off the switch, which is not an abnormality but a process for safety shutdown.

3-4 Cautions about restart

- One must wait for at least 3 minutes before restarting air dryer after it has been shut down. Failure to do this may cause safety devices to trip due to over load.

If it is not possible to restart, refer to "Chapter 5 Troubleshooting."

3-5 Check points before restart

Check following points before you start operation. If any abnormalities occur, immediately stop the operation. Turn off the illuminated switch of the product and then the breaker to the power supply.

- There is no leakage of compressed air.
- Compressed air pressure, temperature, flow rate, and ambient temperature meet the specifications.
- Drain is being discharged from the drain tube.
- The pointer of evaporation thermometer is indicating in the green zone.
- Drainage should not be exhausted from the outlet of the air dryer.
- There are no abnormal sound, vibration, or smelling.

3-6 Precautions for long-term non-operation

- If the product will not be operated for more than 24 hours, for example at the weekend, turn off the ILS (Switch with lamp) or power supply, for energy saving and safety. It is also recommended to release the pressure and residual drainage inside the compressed air piping and this air dryer.
- The residual drainage in the air dryer may splash over the outlet when the operation is re-started, so it is recommended to install a filter on the outlet of the air dryer.

4

Maintenance

4-1 Daily Inspection

Check following points during usual operations. If you find some problems, immediately stop the operation and refer to "Chapter 5 Troubleshooting" as soon as possible.

- There is no air leakage
- The running lamp is lighting during operation
- Drain is being discharged from drain tube
- The pointer of the evaporation thermometer indicates in the green zone when it is running with pressurized air supply.
- The pointer of the evaporated thermometer indicates about 3~10°C lower than that of ambient temperature when the product is suspended with no pressurized air supply.
- There is no abnormal sound or vibration coming up from the product.
- There are no abnormal smell or smoke coming up from the product.

4-2 Periodical Maintenance**4-2-1 Cleaning of ventilation grille (suction grille)**

Clean dust and other foreign particles from the ventilation area with vacuum cleaner or air blow nozzle once a month.

**Caution**

During air blowing, put on protective glass and mask to prevent dusts from coming into throat or eyes.

4-2-2 Service parts

It is recommended to replace the following parts regularly. The interval values shown in this operation manual depend on the operating conditions (ambient temperature, installation environment, etc.), so that they are for reference.

- Table 1. List of parts to be replaced regularly

Description	Recommended replacement period *Note}
Pressure switch	One Million times.
Fan motor	20,000 hours
Magnetic Contactor, Magnetic Switch	One Million times.

*Note) If it is mounted by option "T" (With terminal block for power supply, run, alarm signal and remote operation) or special order.

4-2-3 Cleaning of auto drain strainer

Remove the dust deposited in the auto drain bowl assembly every month. Use neutral detergent for cleaning. If the degree of dirt is heavy and operating failure still continues even after cleaning, replace the product. Also, shorten cleaning interval from the next time.

4-2-4 Replacement of bowl assembly

Replace the bowl assembly with a new one if after cleaning it the auto drain continues operating failure.

**Warning**

- Maintenance of the air dryer should only be carried out by someone with sufficient knowledge and experience of air dryers and related equipment.
- Before carrying out maintenance, the important warnings in this manual must be thoroughly read and understood.

**Danger**

- When replacing or cleaning parts of the air dryer, be sure to remove the compressed air pressure inside the air dryer to "0". Never remove the bowl assembly when the air dryer is operated or air pressure remains inside. It is extremely dangerous if compressed air pressure remains inside the air dryer, as parts may come flying off at speed when loosened, or other unexpected accidents.
- This product has parts that become hot during operation and a power supply with high voltage applied. There is a risk of burns due to heat or electrification by high voltage. Even when operation is shut down after switching off the air dryer's illuminated light, there are also charging lines. When working on the charged sections, be sure to switch off the earth leakage breaker installed before starting work.
- As some parts of the air dryer will remain hot, there is a risk of burns due to residual heat after the power is switched off. So do not carry out replacement work until the temperature of these parts has fallen to 50°C or less. Wait for about 10 to 15 minutes as a guide.
- When carrying out maintenance work on the auto drain strainer and auto drain, there is a risk of touching the drain fluid during work. Please follow the safety procedure for operators specified by customer. (Example: carry out work wearing safety glasses, apron and gloves to prevent discharged fluid from touching the human body.)
- Use neutral detergent solution to clean parts such as the auto drain strainer and auto drain. Never use solvent such as thinner.
- When removing the outer casing panel or bowl assembly of the auto drain, wear gloves to prevent injuries.

How to clean and replace the bowl assembly.

When carrying out maintenance work on the auto drain and auto drain strainer, please follow the steps below.

- (1) Removal of the bowl assembly
 - 1) Turn off the illuminated ON/OFF switch.
 - 2) Disconnect the earth leakage breaker at the power supply or unplug the power plug from the socket.

- 3) Fully close the IN/OUT valves. Only open the bypass when compressed air is required during work.
- 4) Only the point that is necessary for work please remove a decoration panel.

- 5) Close the ball valve.
- 6) Open the bleed valve by turning it anticlockwise to release air left in the product.
- 7) Remove the drain tube from the bowl assembly.
- 8) Hold the bowl assembly lightly and pull down the lock button with thumb. Then, turn the bowl assembly to the left (or right) to 30° to align the marks.
- 9) Release your thumb from the lock button and slowly pull down the bowl assembly (vertically) to remove it.
- 10) Pour solution of neutral detergent into the bowl assembly and shake it well to clean.

(2) Mounting of the bowl assembly

- 1) Check the bowl packing for damage such as scratches, twisting or foreign particles attached to it. Then, apply grease thinly and fit it in the groove in the bowl assembly.
- 2) Fit the bowl assembly to the auto drain body. Turn it until the lock button clicks
- 3) Try to turn the bowl assembly lightly and check that it does not turn. If it turns, start with fitting the bowl assembly to the auto drain body again.

4) Close the bleed valve by turning it clockwise and fit the drain tube as it was.

5) Open the ball valve.

If the bowl assembly is damaged or very dirty, replace it with a new one.

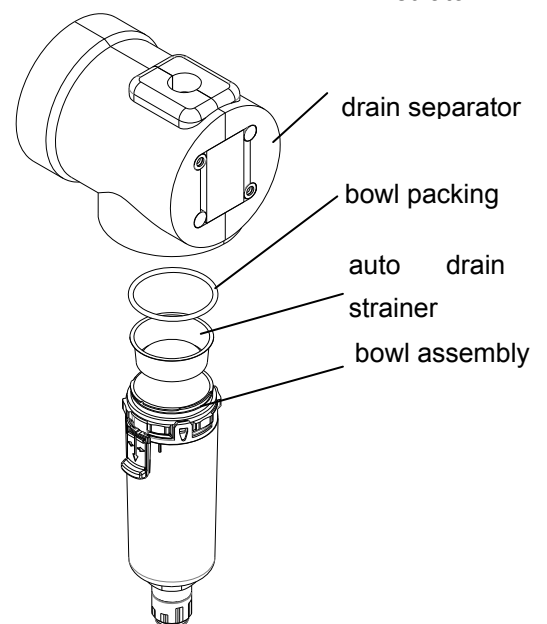
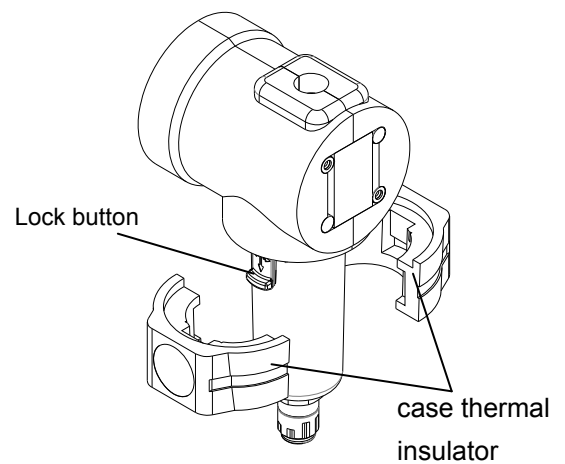
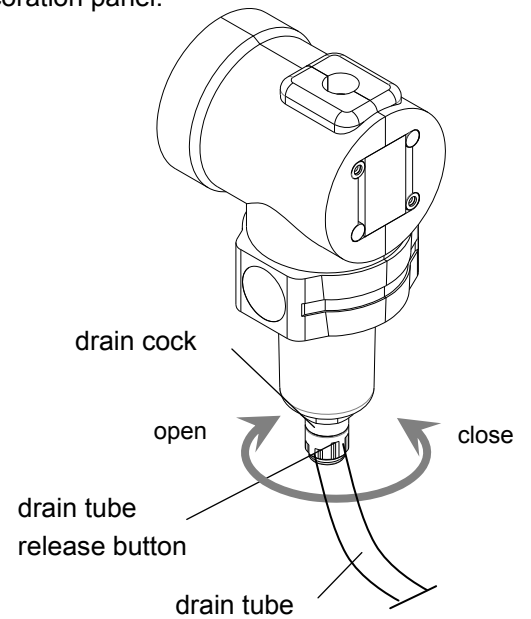

Auto drain product number for replacement

Product number	Product name	QTY	Model	Remarks
AD48-A	Bowl assembly	1	IDU3E/4E/6E	With bowl packing

Note) This product number is the product part number only for the auto drain part except the drain separator part.

The drain separator part cannot be exchanged.

Auto drain strainer and bowl packing product number for replacement

Product number	Product name	QTY	Model
IDF-S0002	Auto drain strainer	1	IDU3E/4E/6E
C42FP-260S	Bowl packing	1	IDU3E/4E/6E

Auto drain strainer is not included in bowl assembly.

Case thermal insulator product number for replacement

Product number	Product name	QTY	Model	Remarks
IDF-S1933	Case thermal insulator	1	IDU3E/4E/6E	For one set with 2 pieces

5

Troubleshooting

5-1 Cause and countermeasure of errors

Should any problem occur, inspect the following table, and if the problem cannot be solved, shut off the power supply and then contact one of our sales offices for further instructions.

Problem	Probable Causes	Remedy
Although the switch with lamp is turned on, the lamp does not light up and the product does not start operating.	The power supply cable has been loosened or disconnected.	Perform proper connection on the power cord and plug.
	The ground fault circuit interrupter is not turned ON.	Check the capacity of the ground fault circuit interrupter. - Check the product was not restarted within 3 minutes after being stopped. - Turn on the ground fault circuit interrupter and try to operate. If the ground fault circuit interrupter turns back off, the insulation failure of the product is suspected. Turn off the power supply and contact SMC.
	Connect the 3-phase power supply incorrectly. (Applicable to products using the 3-phase power supply.)	Replace 2 wires (R phase and T phase) among 3 each other.
Running lamp extinguishes and compressor stops during operation but resumes normal operation illuminating the lamp after a period of time.	The product is installed in an inappropriate location. Ambient temperature is excessive.	- Improve ventilation condition and reduce the ambient temperature as much as possible..
	The ventilation port is obstructed by a wall or clogged with dust.	- Keep the product 600mm or more away from the surrounding walls. - Clean the ventilation ports once every month.
	The compressed air temperature is too high.	- Improve the ventilation in the location where the air compressor is installed, or decrease the ambient temperature to allow the discharge air temperature of the air compressor to go down. - Install an aftercooler after the air compressor to reduce the temperature.
	The fluctuation of the power supply voltage is too large.	- Install a power supply transformer or use a different power supply to provide appropriate voltage. - The fluctuation of the power supply voltage should be kept within +/-10% of the rated voltage.

Problem	Probable Causes	Remedy
The evaporation thermometer is over the green area without hot air coming from the ventilation port (exhaust port). (The compressor for refrigeration has stopped with the lamp lit up.)	The product is installed in an inappropriate location. Ambient temperature is excessive.	- Improve ventilation condition and reduce the ambient temperature as much as possible.
	The ventilation port is obstructed by a wall or clogged with dust.	- Keep the product 600mm or more away from the surrounding walls. - Clean the ventilation ports once every month.
	The compressed air temperature is excessive.	- Improve the ventilation in the location where the air compressor is installed, or decrease the ambient temperature to allow the discharge air temperature of the air compressor to go down. - Install an aftercooler after the air compressor to reduce the temperature.
	The fluctuation of the power supply voltage is too large.	- Install a power supply transformer or use a different power supply to provide appropriate voltage. - The fluctuation of the power supply voltage should be kept within +/-10% of the rated voltage.
	The built-in overload relay of the compressor for refrigeration has started.	- Check the product was not restarted within 3 minutes after being stopped.
The evaporation thermometer is over the green area with hot air coming from the ventilation port (exhaust port).	The product is installed in an inappropriate location. Ambient temperature is excessive.	- Improve ventilation condition and reduce the ambient temperature as much as possible.
	The ventilation port is obstructed by a wall or clogged with dust.	- Keep the product 600mm or more away from the surrounding walls. - Clean the ventilation ports once every month.
	The compressed air temperature is excessive.	- Improve the ventilation in the location where the air compressor is installed, or decrease the ambient temperature to allow the discharge air temperature of the air compressor to go down. - Install an aftercooler after the air compressor to reduce the temperature.
Moisture is generated at the downstream of the compressed air line.	The bypass valve is open.	- Be sure to fully close the bypass valve.
	Condensate is not drained from the auto drain.	- Check the draining piping is not used in an upward direction nor bent. - Check the auto drain. - Check the auto drain strainer.
	The pressure fluctuation (pulsation) of the compressed air is too high.	- Install an air tank on the primary side of the dryer. - Avoid intermittent compressed air flow.
	Residual drainage in the air dryer splashes over when the unit is re-started.	- Install a filter on the outlet of the air dryer. - Blow the unit by air to eliminate the residual drainage after stopping or re-starting the operation.
	The piping of a different system without an air dryer joins the piping after the product.	- Install another air dryer (this product) in that system. - Keep the two systems separate.
The compressed air pressure is too large.	The valves at the inlet and outlet of the piping of the product are not fully opened.	- Be sure to fully open the valves at the inlet and outlet of the product.
	The air filter, etc. installed in the compressed air piping has got clogged.	- Replace the element of the air filter. (Follow the Operation Manual of the equipment.)

6

References

6-1 Specifications

Specification		Model	IDU3E-10/20	IDU4E-10/20	IDU6E-10/20
Rated Condition	Air Flow Rate	50Hz	0.32	0.52	0.75
	m ³ /min (ANR)(Note 1)	60Hz	0.37	0.57	0.82
	Operating Pressure		0.7MPa		
	Inlet Air Temperature		55°C		
	Ambient Temperature		32°C		
	Pressurized Dew Point		10°C		
Operating Range	Working Fluid		Compressed Air		
	Inlet Air Temperature		5 ~ 80°C		
	Inlet Air Pressure		0.15 ~ 1.0MPa		
	Ambient Temperature		2 ~ 40°C(Relative Humidity of 85% or less)		
Electrical Specification	Power source	100VAC(50/60Hz)	Single phase AC100/100 , 110V [Voltage fluctuations± 10%]		
		200VAC(50/60Hz)	Single phase AC200/200 , 220V [Voltage fluctuations± 10%]		
	Operating current (Note 2) A	100VAC(50/60Hz)	2.4/2.5	3.0/3.1	5.7/5.7
		200VAC(50/60Hz)	1.2/1.3	1.5/1.5	3.4/3.0
	Power consumption (Note 2) W	100VAC,200VAC (50/60Hz)	180/202	208/236	385/440
Circuit Breaker (Note 3)	100VAC	10A			
	200VAC	5A			
Condenser		Plate fin tube type with forced air cooling			
Refrigerant		R134a (HFC)			
Refrigerant Charge(AC100V/200V) g		200±5	250±5	260±5	
Drain Connection		Rc3/8	Rc1/2	Rc3/4	
Drain Connection		10mm			
Coating Color		Panel: Urbanwhite 1 Base: Urbangray 2			
Weight kg		23	27	28	
Applicable Compressor(Standard) kW		2.2	3.7	5.5	

Note1: The data for m³/min (ANR) is referring to the conditions of 20°C, 1atm. pressure & relative humidity of 65%.

Note 2: The value is that of under specified condition.

Note 3: Install GFCI breaker with sensitivity of 30mA.

Note 4: When short period power shortage (including instantly recovered shortage) is recovered, it may take a longer starting period than usual starting or may not start due to the protective devices.

Specification		Model	IDU3E-23	IDU4E-23	IDU6E-23
Rated Condition	Air Flow Rate	50Hz	0.32	0.52	0.75
	m ³ /min (ANR)(Note 1)	60Hz	0.37	0.57	0.82
	Operating Pressure		0.7MPa		
	Inlet Air Temperature		55°C		
	Ambient Temperature		32°C		
	Pressurized Dew Point		10°C		
Operating Range	Working Fluid		Compressed Air		
	Inlet Air Temperature		5 ~ 80°C		
	Inlet Air Pressure		0.15 ~ 1.0MPa		
	Ambient Temperature		2 ~ 40°C(Relative Humidity of 85% or less)		
Electrical Specification	Power source		Single phase AC230V [Voltage fluctuations± 10%]		
	Operating current (Note 2) A		1.5	1.6	2.9
	Power consumption (Note 2) W		210	220	400
	Circuit Breaker (Note 3)		5A		
Condenser		Plate fin tube type with forced air cooling			
Refrigerant		R134a (HFC)			
Refrigerant Charge(AC100V/200V)	g	230±5	270±5	290±5	
Drain Connection		Rc3/8	Rc1/2	Rc3/4	
Drain Connection		10mm			
Coating Color		Panel: Urbanwhite 1 Base: Urbangray 2			
Weight	kg	23	27	28	
Applicable Compressor(Standard)	kW	2.2	3.7	5.5	

Note1: The data for m³/min (ANR) is referring to the conditions of 20°C, 1atm. pressure & relative humidity of 65%.

Note 2: The value is that of under specified condition.

Note 3: Install GFCI breaker with sensitivity of 30mA.

Note 4: When short period power shortage (including instantly recovered shortage) is recovered, it may take a longer starting period than usual starting or may not start due to the protective devices.

6-2 Refrigerant with GWP reference

Refrigerant	Global Warming Potential (GWP)	
	Regulation (EU) No 517/2014 (Based on the IPCC AR4)	Revised Fluorocarbons Recovery and Destruction Law (Japanese law)
R134a	1,430	1,430
R404A	3,922	3,920
R407C	1,774	1,770
R410A	2,088	2,090

Note1: This product is hermetically sealed and contains fluorinated greenhouse gases.

Note2: See specification table for refrigerant used in the product.

6-3 Dimintions

IDU3E / IDU4E / IDU6E

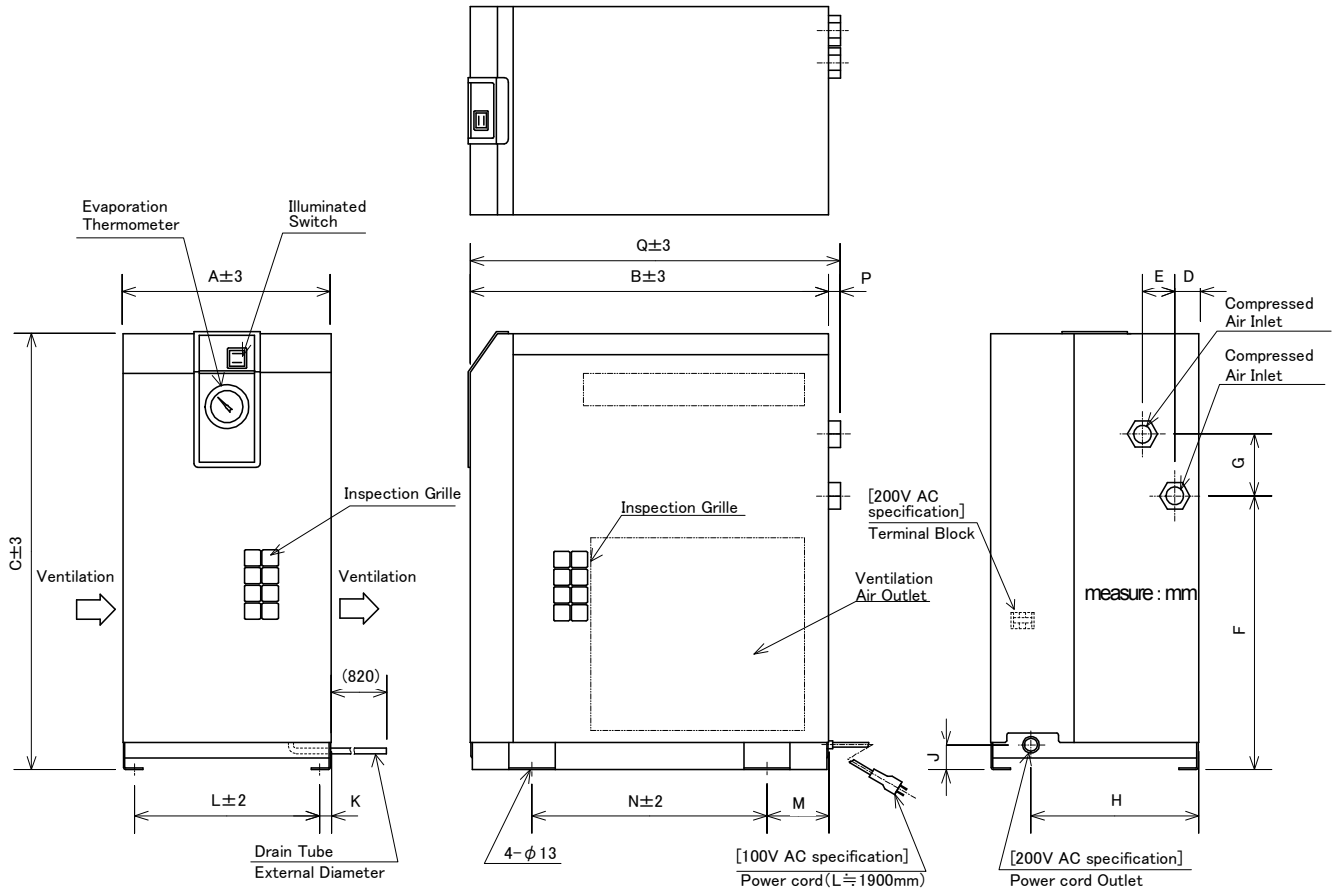

measure : mm

Model	Port size	A	B	C	D	E	F	G	H	J	K	L	M	N	P	Q	
IDU3E	Rc3/8	270	440	498	31	42±2	285	80±2	230	32	15	240±2	80	275±1	15	455	
IDU4E	Rc1/2		470	568			355							300±1		13	483
IDU6E	Rc3/4		470	568			355							300±1		15	485

6-4 Electrical Circuit

IDU3E/4E

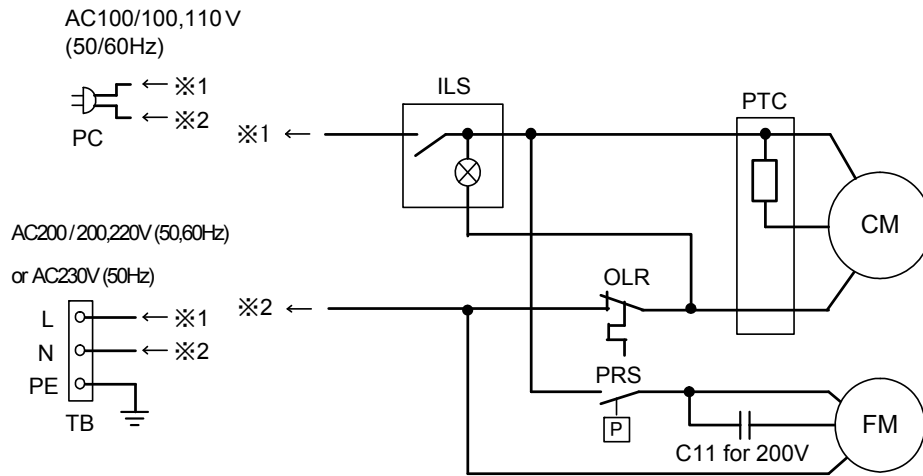

IDU6E-10

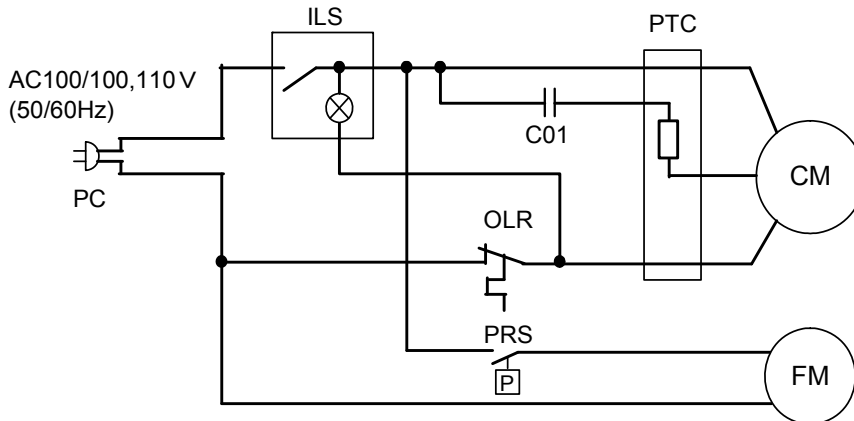

IDU6E-20/23

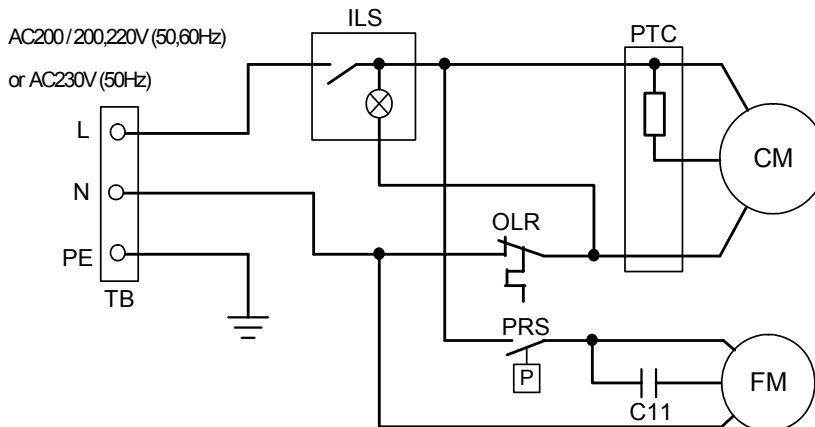

Symbol	Descrppion	Symbol	Descrppion
CM	Compressor Motor	PRS	Pressure Switch
FM	Fan Motor	C01/C11	Capacitor (Compressor / Fan Moter)
OLR	Overload	TB	Terminal Block
PTC	PTC Starter	PC	Power Supply Code
ILS	Switch with lamp		

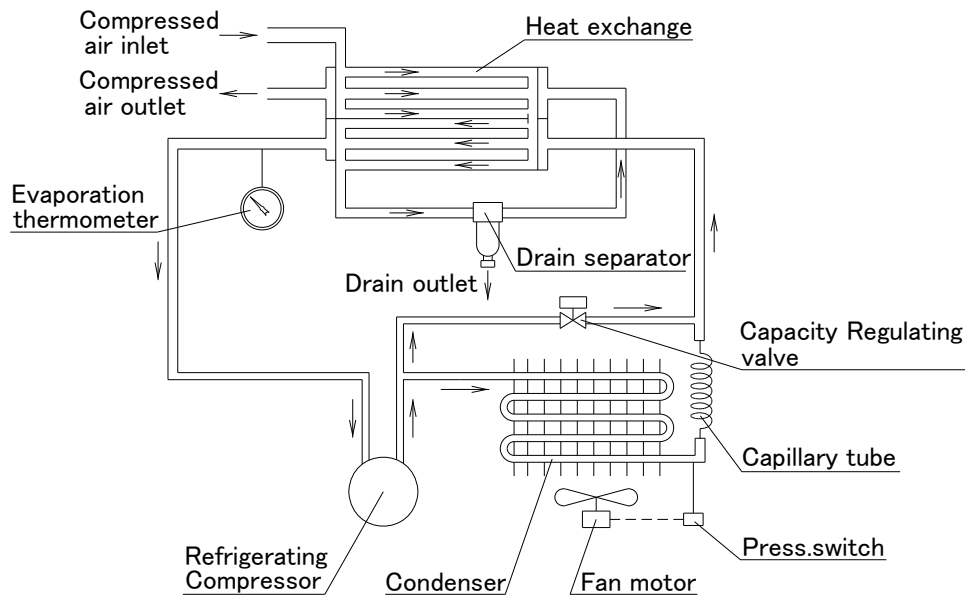
6-5 Compressed Air and Refrigerant Circuit / Operation Principles**Compressed Air Circuit**

Hot and humid air which has come in an air dryer firstly enters reheating part, exchanges its heat with dehumidified cold air and becomes cooler. Then, it enters cooling part and gives its heat to cold fleon, which cools and dehumidifies further, and separates its moisture. Finally, it exchanges its heat with hot and humid air which comes in the air dryer and goes out from the air dryer as warm and dry air.

Refrigerant Circuit

The Fluorocarbon charged in the refrigerant circuit is compressed by the compressor and cooled by the condenser to become liquid. Then, going through the capillary tube, it is decreased the pressure to reach a low temperature. Passing through the cooler part, it draws heat from compressed air and intensely boils. Finally it is inhaled into the compressor again. The capacity control valve opens to prevent dew drops from freezing when compressed air is cooled enough.



7 Specification for Option C

7-1 Specifications

The surface of copper tube is painted with a special epoxy resin for the rust proofing. The parts covered with aluminum fins and insulations are not painted.

7-2 Precautions for the installation and handling of the product

- 1) The surface of copper tube is painted with a special epoxy to improve the rust proof effect from corrosive gas, but it is not perfect rust proof. Therefore, avoid installing the product in the place exposed to corrosive gas as much as possible.
- 2) If any of the painted surfaces of copper tube is damaged, such as when the panels are removed for maintenance, the effect of its rust proofing painting is lost. Do not give damage any painted surfaces of copper tube.

8 Specification for Option K

8-1 Safety instructions

When handling the product, take care to the following precautions.

⚠ Warning

- Do not remove the auto drain with the air pressure remaining internally. If the compressed air is left in the product, when some part is loosened, it may cause sudden lurching or other unexpected accidents.
- When removing the panel, wear protective gloves to prevent injuries.
- There is a risk of touching drained waste liquid during replacement.
When draining, follow the user's own procedure to keep operators safe. (E.g. Wear protective goggles, apron and gloves to prevent contact with the drained condensate.)
- When oils can enter the drained condensate, waste water treatment is necessary. Follow the bylaws or rules of the local municipality for disposal.

8-2 Specifications

The maximum operating pressure 1.6MPa. A metal bowl with a level gauge which can confirm the water label is used for auto drain.

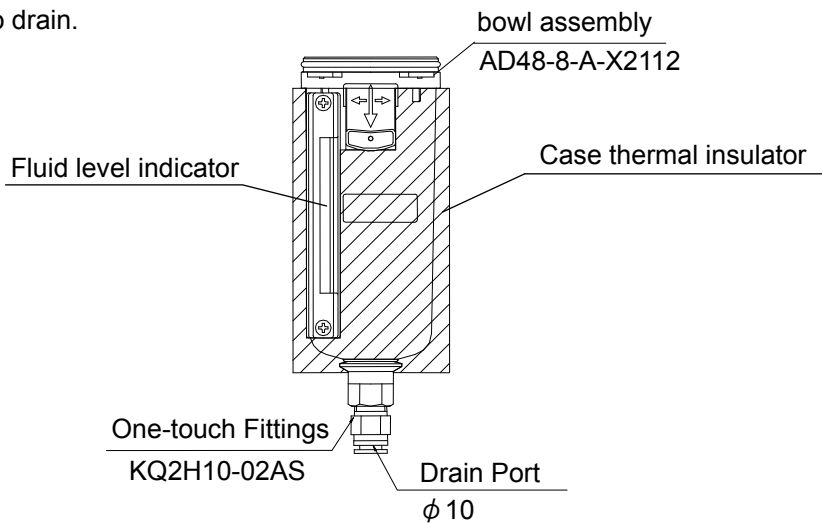

	Model	IDU3E/4E/6E-*K
Auto drain type		Float type
Auto drain valve type		N. O. (Normal Open: Open under non-energized status.)
Operating pressure		0.15 to 1.6MPa

Auto drain product number for replacement

Product number	Product name	QTY	Remarks
IDF-S1926	Bowl assembly thermal insulator	1	—
AD48-8-A-X2112	Bowl assembly	1	With bowl packing

Auto drain Parts

Product number	Product name	QTY
IDF-S0002	Auto drain strainer	1
C42FP-260S	Bowl packing	1

Case thermal insulator product number for replacement

Product number	Product name	QTY
IDF-S0529	Case thermal insulator	1

9 Specification for Option L

9-1 Safety instructions

When handling the product, take care to the following precautions.

 Warning
<ul style="list-style-type: none"> - Do not remove the auto drain with the air pressure remaining internally. If the compressed air is left in the product, when some part is loosened, it may cause sudden lurching or other unexpected accidents. - When removing the panel, wear protective gloves to prevent injuries. - There is a risk of touching drained waste liquid during replacement. When draining, follow the user's own procedure to keep operators safe. (E.g. Wear protective goggles, apron and gloves to prevent contact with the drained condensate.) - When oils can enter the drained condensate, waste water treatment is necessary. Follow the bylaws or rules of the local municipality for disposal.

9-2 Specifications

The maximum operating pressure 1.6MPa. The float type auto drain used in the standard air dryer is replaced with a heavy duty auto drain (ADH4000-04). Please attach this auto drain to the product by customer.

Item \ Model	IDU3E-***-L	IDU4E-***-L	IDU6E-***-L
Auto drain type	Floating type		
Auto drain valve type	N.O.(normally opened: Released without pressurization)		
Inlet Air Pressure <small>Note)</small>	0.15 to 1.6MPa		

Note) Use for air compressor with flow more than 50L/min (ANR).

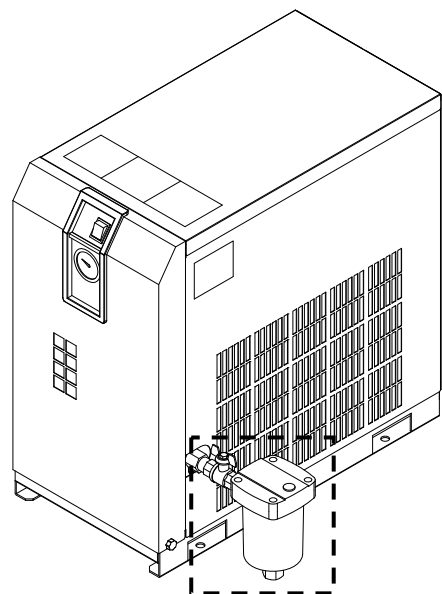

Parts shown in are accessories attached to the unit.

9-3 Installation of heavy duty auto drain

1) Hold the hexagon-head part (width across flats: 32) at port Rc1/2 of the air dryer with spanner.

Then install nipple, ball valve (width across flats: 25).

Note 1) Put up the seal tape or the sealant to the nipple. Tightening torque: 28 to 30Nm

2) Hold the ball valve with the spanner. Then install a nipple and a heavy duty auto drain.

Install with "out port" down in a vertical position. Inclination from the vertical line should be less than 5°.

3) Install one-touch fitting (width across flats: 22) to drain port (width across flats: 27) and the drain tube.

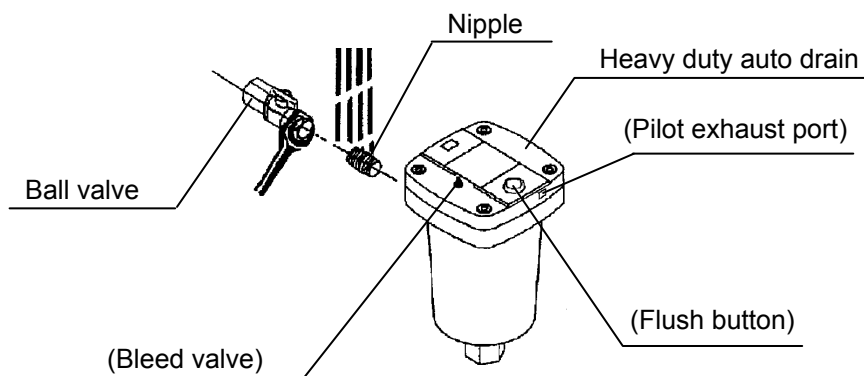

Note 2) Prepare a drain piping of out port by yourself.

Note 3) When not draining sufficiently, open the bleed valve so that drain could run through easily.

9-4 Maintenance

1) As a preventive maintenance, press the flush button of the heavy-duty auto drain regularly to clean the discharge valve (for flushing).

2) The pilot exhaust of the heavy-duty auto drain is at the position shown in the figure. **Do not close the exhaust port.** Also, clean the exhaust port to prevent it from getting blocked by dust.

3) Close the ball valve before removing the heavy duty auto drain and open the bleed valve or push the flushing button and confirm air pressure is released.

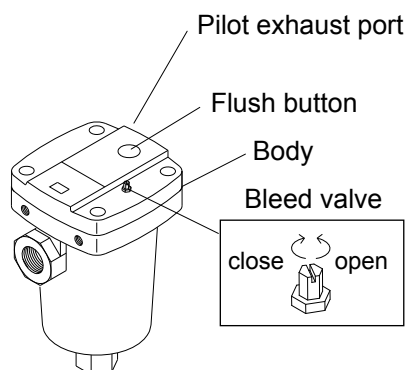

10**Specification for Option M**

For IDU3E/4E/6E-10/20

10-1 Safety instructions

When handling the product, take care to the following precautions.

**Warning**

- Do not remove the auto drain with the air pressure remaining internally. If the compressed air is left in the product, when some part is loosened, it may cause sudden lurching or other unexpected accidents.
- When removing the panel, wear protective gloves to prevent injuries.
- There is a risk of touching drained waste liquid during replacement.
When draining, follow the user's own procedure to keep operators safe. (E.g. Wear protective goggles, apron and gloves to prevent contact with the drained condensate.)
- When oils can enter the drained condensate, waste water treatment is necessary. Follow the bylaws or rules of the local municipality for disposal.

**Warning**

- Only qualified persons are allowed to wire the product.
- Use a power supply suitable for the specifications of the product.
 - Be sure to connect the ground connection.
 - Grounding should never be connected to a water line, gas line or lightning rod.
 - Multiple wiring is dangerous because it may lead to heat generation and cause a fire.
 - Do not modify the electrical wiring of the power supply.

10-2 Specifications

The float type auto drain used in the standard air dryer is replaced with a motor type auto drain (ADM200). The customer is required to mount the auto drain to the air dryer.

Items	Model	IDU3E/4E/6E-10-M	IDU3E/4E/6E-20-M
Parts number		IDF-S0087	IDF-S0090
Max. operating pressure		1.0MPa	
Operating fluid		Compressed air	
Operating cycle		Once every minute	
Operating time		2 seconds/cycle	
Power supply voltage of dryer		AC100V(50/60Hz)	AC200V(50/60Hz)
Power consumption		4W	

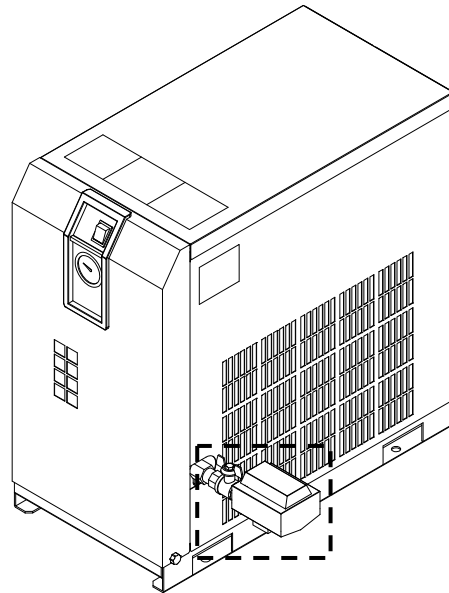

Parts shown in are accessories attached to the unit.

10-3 Installation of motor type auto drain

1) Hold the hexagon-head part at port Rc1/2 of the air dryer with spanner.

Then install nipple, ball valve (width across flats: 25).

Note 1) Put up the seal tape or the sealant to the nipple. Torque R1/2: 28 to 30Nm

2) Hold the ball valve with the spanner. Then install a nipple and a motor type auto drain.

Install with "out port" down in a vertical position. Inclination from the vertical line should be less than 5°.

3) Install one-touch fitting (width across flats: 17) to drain port (width across flats: 30) and the drain tube.

4) Connect the 2 electric cables coming out from the auto drain with the two electric cables from the dryer unit. Insert the drip-proof connector to the deepest part.

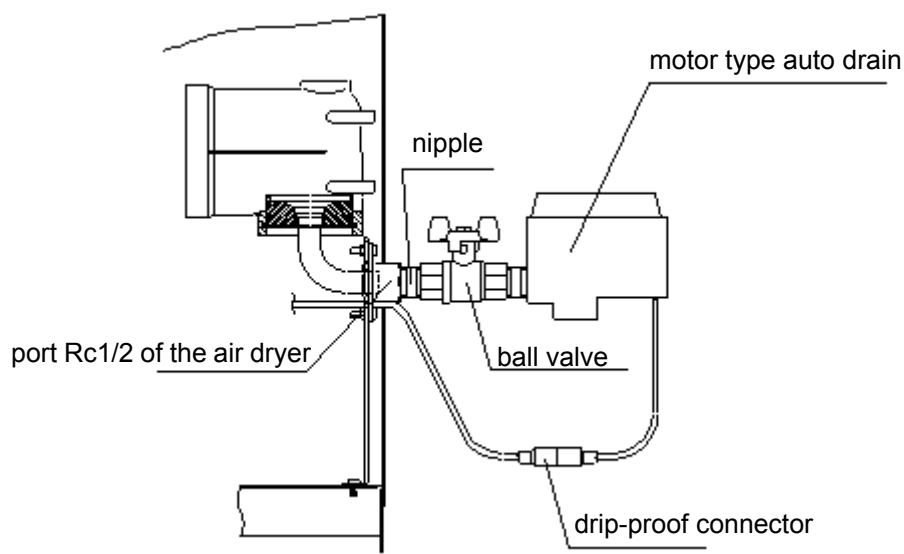

10-4 Electric circuit

For details of the electric circuit, refer to the label on the back of the front panel of this product (see page 1-1).

11

Specification for Option R

11-1 Safety instructions

When handling the product, take care to the following precautions.

**Warning**

Only qualified persons are allowed to wire the product.

- Before wiring, be sure to shut off the power supply. Never perform wiring work while the product is energized.
- Ensure a stable power supply with no voltage surges.
- Use a power supply suitable for the specifications of the product.
- Be sure to connect the ground connection.
- Grounding should never be connected to a water line, gas line or lightning rod.
- Multiple wiring is dangerous because it may lead to heat generation and cause a fire.
- Do not modify the electrical wiring of the power supply.

11-2 Specifications

Customer should connect power cords at primary side of ground fault circuit interrupter, which is different from standard such as plug-in type (AC100V) or terminal block type (AC200V). The ground fault circuit interrupter is located at the rear side (air inlet and outlet side).

Model	IDU3E/4E/6E-10-R	IDU3E/4E/6E-20/23-R
Item		
Rated current : (A)	10	5
Current sensitivity : (mA)	30	

11-3 Power supply connection procedure

- 1) Take off the rear panel.
- 2) Insert the power cable prepared by the customer into the power code fixture and bring the power cable near the terminal base through the base hole.
- 3) Connect the power cable to the terminal of the GFCI.

To the user's machine

Terminal connecting screw: M5

Connector width: 9.5mm or less

Applicable electrical wire: 1.25mm² or more

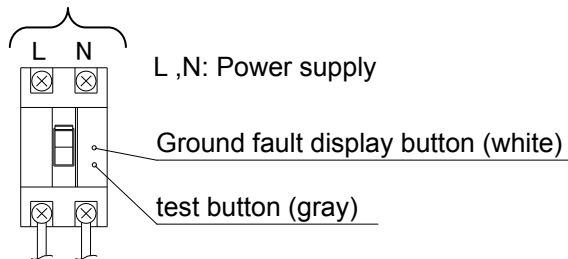

- 4) Connect the grounding cable.
 - AC100V: Connect the ground line to M4 screw on the left side of the GFCI (with the name plate).
 - AC200V: Connect it to the terminal block (ground connection thread: M3)
- 5) Mount the rear panel.

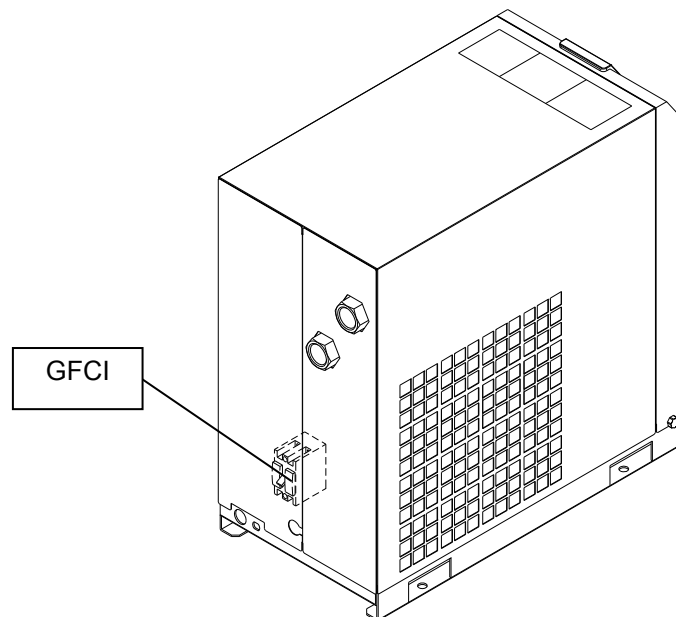

11-4 Cautions for handling the GFCI

- 1) When the breaker is tripped, cut off the power supply and contact the nearest sales distributor or SMC sales.
 - With the Ground fault display button (white) released → Current leakage
 - With the Ground fault display button (white) pressed → Over current
- 2) Check the operation once a month by pressing the test button (gray) with the breaker on and Switch with Lamp off.

11-5 Electric circuit

For details of the electric circuit, refer to the label on the back of the front panel of this product (see page 1-1).

12

Specification for Option S

For IDU3E/4E/6E-10

12-1 Safety instructions

When handling the product, take care to the following precautions.

**Warning**

Only qualified persons are allowed to wire the product.

- Before wiring, be sure to shut off the power supply. Never perform wiring work while the product is energized.
- Ensure a stable power supply with no voltage surges.
- Use a power supply suitable for the specifications of the product.
- Be sure to connect the ground connection.
- Grounding should never be connected to a water line, gas line or lightning rod.
- Multiple wiring is dangerous because it may lead to heat generation and cause a fire.
- Do not modify the electrical wiring of the power supply.

12-2 Specifications

The option allows the connection of a power cable to a terminal block.

IDU*-20 is equipped as standard.

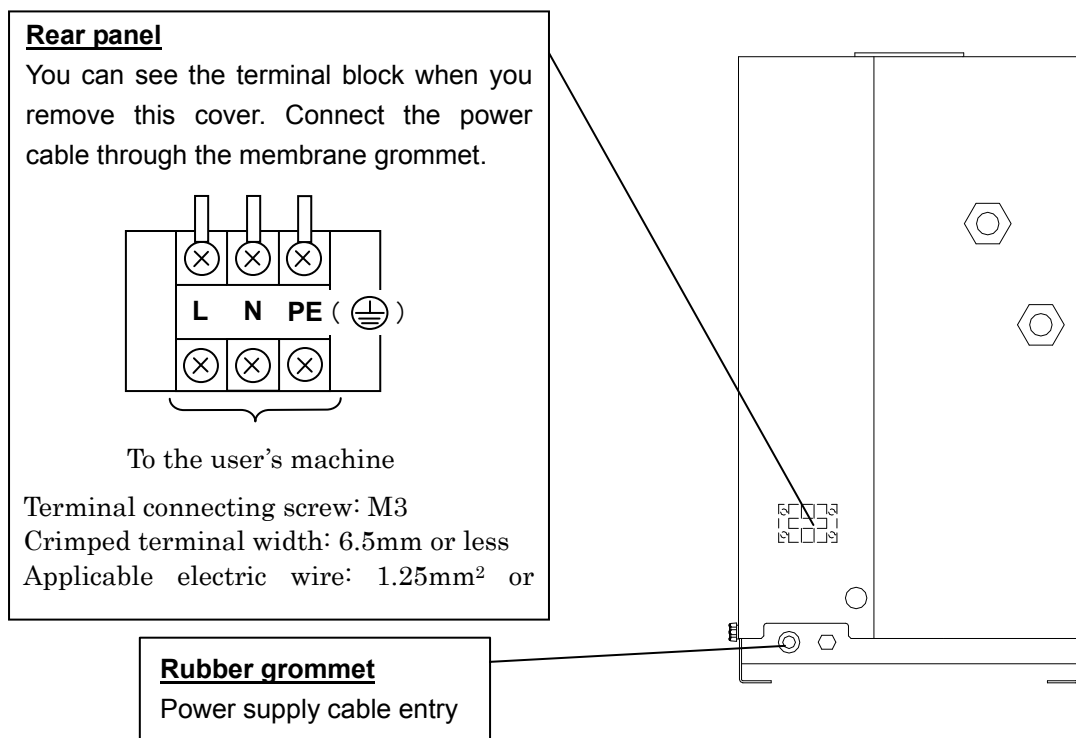
**12-3 Electric circuit**

For details of the electric circuit, refer to the label on the back of the front panel of this product (see page 1-1).

13**Specification for Option T****13-1 Safety instructions**

When handling the product, take care to the following precautions.

 Warning

Only qualified persons are allowed to wire the product.

- Before wiring, be sure to shut off the power supply. Never perform wiring work while the product is energized.
- Ensure a stable power supply with no voltage surges.
- Ensure that an ground fault circuit interrupter with appropriate capacity for ground fault and load is used in the power supply of the product to prevent electrical shock and burnout of the compressor motor.
- Use a power supply suitable for the specifications of the product.
- Be sure to connect the ground connection.
- Grounding should never be connected to a water line, gas line or lightning rod.
- Multiple wiring is dangerous because it may lead to heat generation and cause a fire.
- Do not modify the electrical wiring of the power supply.
- For use in Europe, install a breaker compliant with applicable IEC standards to the power supply of the product.

13-2 Specifications

This option installs a terminal block that has outputs for the operation and failure signals.

- The operation and failure signals are no voltage contact style
 - Operation · · · · When the product is operating; Close
 - Failure · · · When the product stops due to failure; Close
- Contact capacity
 - AC200V / 2A
 - DC24V / 2A
 - (Minimum applicable load: 20V / 5mA)

13-3 Remote operation

- When a remote operation is used, the switch with lamp should remain on; turn the power supply on and off to start and stop operations.
- Wait 3 minutes before restart after the air dryer is stopped for both manual and remote operation. Restart within 3 minutes will cause the protective equipment (overload relay) to move and the operation will be prevented.
Also, the frequency of starting and stopping should be 5 times per hour or less (to prevent the motor failed.)

13-4 How to connect the power and signal cable

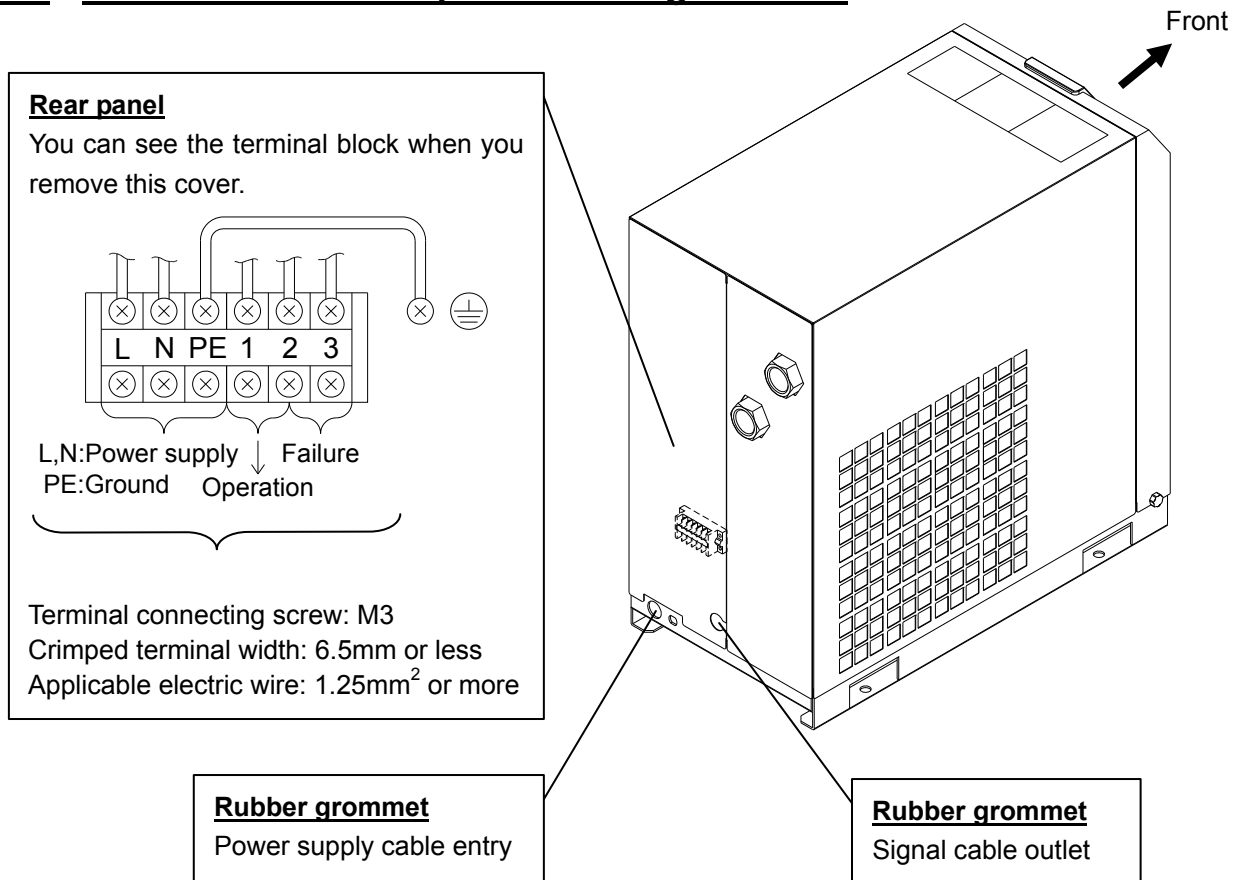

Connect the power cable and signal cable in the following procedures.

- 1) Take off the front panel.
- 2) Insert the power cable prepared by the customer into the power cord inlet (with rubber grommet) and bring the power cable near the terminal block through the base hole.
- 3) Connect the power cable to the terminal.
- 4) Insert the signal cable prepared by the customer into the signal cord inlet (with rubber grommet) and bring the signal cable near the terminal block.
- 5) Connect the signal cable to the each terminal.
- 6) Put back the front panel.

13-5 How to re-start the operation

The output of the abnormal signal can be stopped by turning off the switch with light. Remove the cause of abnormal operation and leave it for 3 minutes or longer after the stopping the operation, and turn on the switch with light to re-start.

13-6 Electric circuit

IDU3/4E-10-T

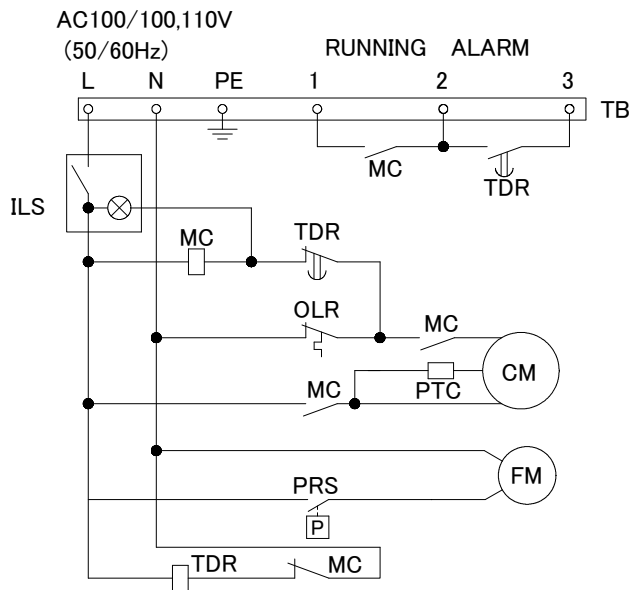

IDU3E/4E-20/23-T

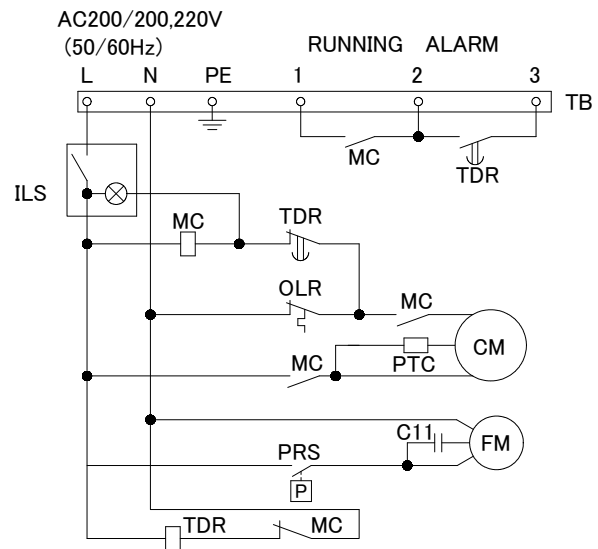

IDU6-10-T

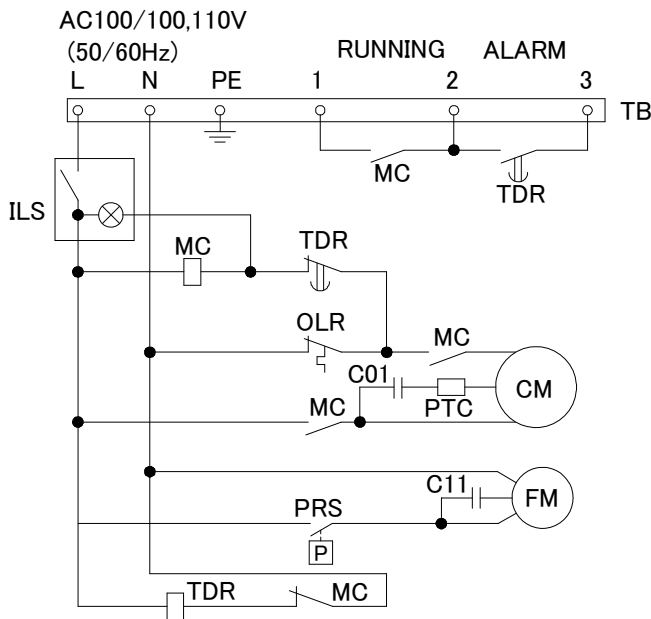

IDU6E-20/23-T

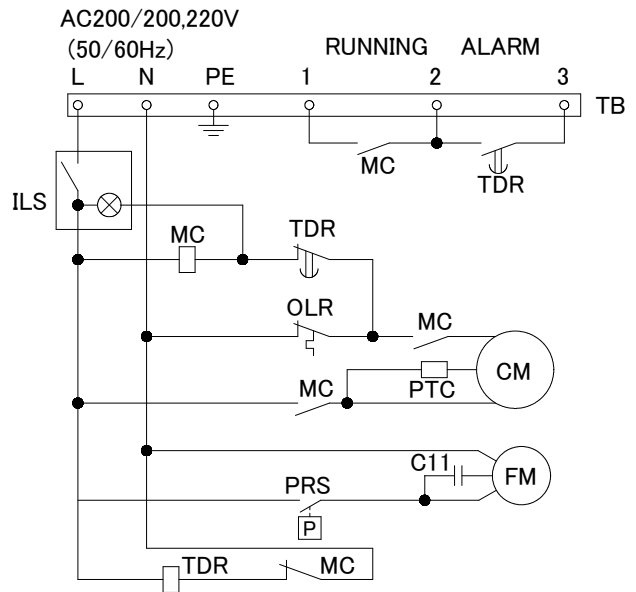

Symbol	Description	Symbol	Description
CM	Refrigerating compressor	TB	Terminal block
FM	Fan motor	C01	Capacitor for running refrigerating compressor
OLR	Overload relay	C11	Capacitor for running fan motor
ILS	Switch with lamp	TDR	Time delay relay
PTC	PTC Starter	MC	Magnetic contactor
PRS	Pressure switch		

14 Specification for Option V

This product mounts the timer operated auto drain in Item 2 Specifications. When performing the installation and maintenance work for the product, the following points must be understood and followed. Additionally, read Item 3 for replacement work.

For IDU3E/4E/6E-23

14-1 Safety instructions

When handling the product, take care to the following precautions.

Warning

1. Do not remove the auto drain if air pressure remains of the product. When removing the auto drain, stop the supply of air to the primary side of the product, exhaust the air from the secondary side and ensure there is no residual pressure. If the air pressure is left at the inside of the product, parts could suddenly pop out and cause accident when loosened.
2. Put gloves to prevent injury when removing the auto drain.
3. Operator could touch the drain waste from repalced auto drain. Follow the procedures prepared by the customer to keep safety of operators. (Ex. Put protective goggles, apron and/or gloves to protect body from toucing the drain waste for replacement worken replacing the product.)

Warning

Only qualified person must perform wiring.

1. Provide the power suitable for the product specifications.
2. Be suer to ground the product for the safety. Do not ground to water pipe, gas tube or lightening rod line.
3. Do not connect too many wires to the same outlet, which could results in heat generation and fire.
4. Do not retrofit the wiring of the dryer and the power supply line.

14-2 Specifications

The timer is set to have ON time of 0.5sec and OFF time of 0.5min. at the time of shipment from the factory. Do not change this timer setting. If it is changed, water could be discharged from the outlet line of the dryer. Service parts number will change depending on the power supply voltage of the dryer.

Model	IDU3E/4E/6E-23-V
Order number (service parts)	IDF-S0198
Max. operating pressure	1.6MPa
Power supply voltage of drain timer	AC230V±10% (50Hz)
ON time	0.5sec
OFF time	0.5min

14-3 How to perform maintenance

The product needs to be maintained. Clean it in the following procedure periodically.

- 1) Close the ball valve.
- 2) Press the test switch and make the residual pressure zero.
- 3) Remove the strainer and clean it.
- 4) Reassemble the strainer and open the ball valve.

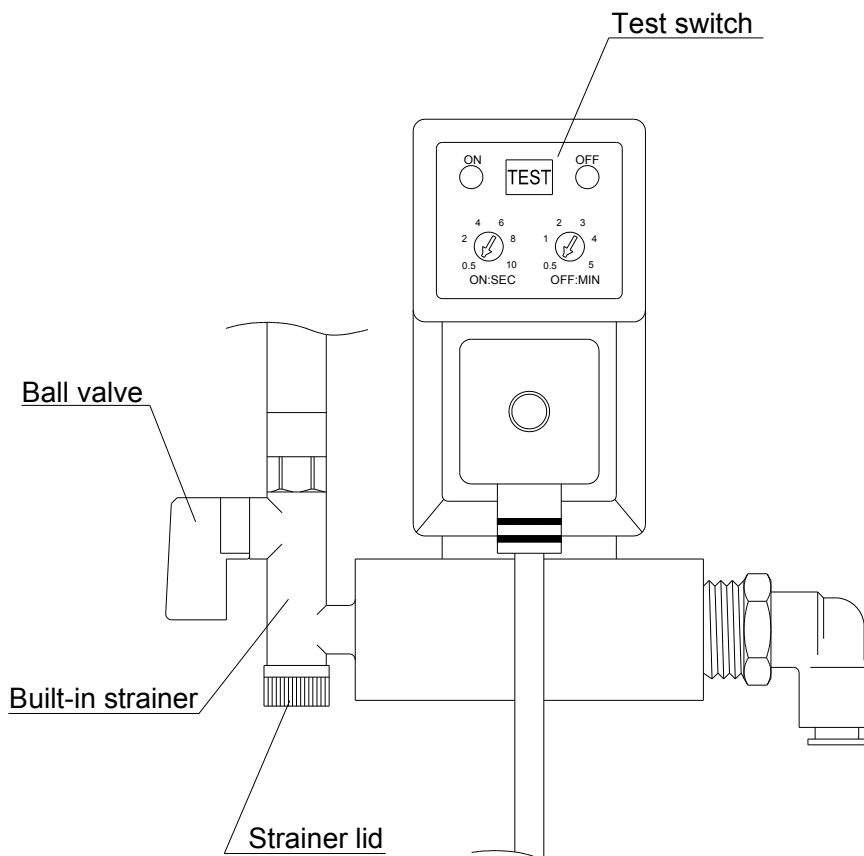

14-4 Electric circuit

The power supply of timer operated auto drain is connected to the dryer main unit. Customers do not have to wire

For details of the electric circuit, refer to the label on the back of the front panel of this product (see page 1-1).

15 Service Record

15-1 Service Record

It is recommended to keep a maintenance/service record.

Parts No.	Description	Maintenance/Service Work Description	Date

Revision
Revision A : Nov.2019

SMC Corporation

4-14-1, Sotokanda, Chiyoda-ku, Tokyo 101-0021 JAPAN
Tel: + 81 3 5207 8249 Fax: +81 3 5298 5362
URL <https://www.smcworld.com>

Note: Specifications are subject to change without prior notice and any obligation on the part of the manufacturer.
© 2019 SMC Corporation All Rights Reserved

