

OPERATION MANUAL

PRODUCT NAME: PARALLEL GRIPPER

MODEL : MHK 2 - 1 2 □

MHK 2 - 1 6 □

MHK 2 - 2 0 □

MHK 2 - 2 5 □

MHKL 2 - 1 2 □

MHKL 2 - 1 6 □

MHKL 2 - 2 0 □

MHKL 2 - 2 5 □

- Read this operation manual carefully to understand before installation and operation.
- Pay extra attention on the clause concerning the safety.
- Keep this operation manual available whenever necessary.

SMC CORPORATION

Contents

1. Specifications

2. Operating method

2 - 1. Environment

2 - 2. Air source

2 - 3. Lubrication

2 - 4. Mounting

2 - 5. Selection

2 - 6. Installation and Setting of Auto Switch

2 - 7. Piping

3. Maintenance

3 - 1. Notes



3 - 2. Structural drawing / Parts List

3 - 3. Replacing Procedure of Piston Ass'y

Notes to users

Safety Instructions

These safety instructions are intended to prevent a hazardous situation and/or equipment damage. These instructions indicate the level of potential hazard by label of “Caution”, “Warning”, or “Danger”. To ensure safety, be sure to observe ISO 4414 ^{Note 1)}, JIS B 8370 ^{Note 2)} and other safety practices.

- | |
|--|
|  Caution : Operator error could result in injury or equipment damage. |
|  Warning : Operator error could result in serious injury or loss of life. |
|  Danger : In extreme conditions, there is a possible result of serious injury or loss of life. |

(Note-1) ISO 4414 : Pneumatic fluid power—Recommendations for the application of equipment to transmission and control systems.

(Note-2) JIS B 8370 : Pneumatic systems axiom.



WARNING

- | |
|--|
| <p>① <u>The compatibility of pneumatic equipment is the responsibility of the person who designs the pneumatic system or decides its specifications.</u></p> <p>Since the products specified here are used in various operating conditions, their compatibility for the specific pneumatic system must be based on specifications or after analyses and/or tests to meet your specific requirements.</p> <p>② <u>Only trained personnel should operate pneumatically operated machinery and equipment.</u></p> <p>Compressed air can be dangerous if an operator is unfamiliar with it. Assembly, handling or repair of pneumatic systems should be performed by trained and experienced operators.</p> <p>③ <u>Do not service machinery/equipment or attempt to remove component until safety is confirmed.</u></p> <ol style="list-style-type: none">1. Inspection and maintenance of machinery/equipment should only be performed after confirmation of safe locked-out control positions.2. When equipment is to be removed, confirm the safety process as mentioned above. Cut the supply pressure for this equipment and exhaust all residual compressed air in the system. |
|--|

3. Before machinery/equipment is re-started, take measures to prevent shooting out of cylinder piston rod etc. (Bleed air into the system gradually to create back-pressure.)

④ Contact SMC if the product is to be used in any of the following conditions :

1. Conditions and environments beyond the given specifications, or if product is used outdoors.
2. Installation on equipment in conjunction with atomic energy, railway, air navigation, vehicles, medical equipment, food and beverage, recreation equipment, emergency stop circuits, press applications, or safety equipment.
3. An application which has the possibility of having negative effects on people, property, or animals, requiring special safety analysis.

1. Specifications

Specifications

MHK2 Series

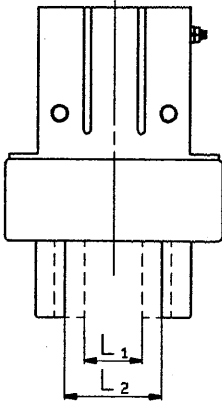

MHKL2 Series

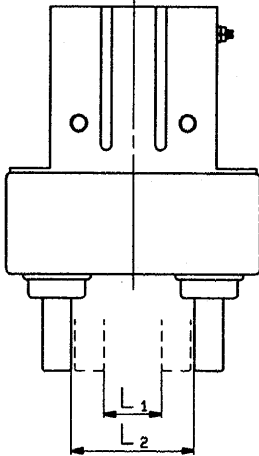

Action	Model	Bore Size	Max. Operating frequency c.p.m.	Opening /closing stroke mm (L ₂ -L ₁)	Closed dia. mm (L ₁)	Open dia. mm (L ₂)	Mass	
Double acting	MHK2-12D	12	120	4	9	13	75	
	MHK2-16D	16		6	14.6	20.6	113	
	MHK2-20D	20		10	16	26	235	
	MHK2-25D	25		14	19	33	440	
Single acting	normally open	MHK2-12S		12	4	9	13	76
		MHK2-16S		16	6	14.6	20.6	114
		MHK2-20S		20	10	16	26	237
		MHK2-25S		25	14	19	33	443
	normally closed	MHK2-12C		12	4	9	13	76
		MHK2-16C		16	6	14.6	20.6	115
		MHK2-20C		20	10	16	26	237
		MHK2-25C		25	14	19	33	443
Double acting	MHKL2-12D	12		90	11	9	20	104
	MHKL2-16D	16			14	14.6	28.6	164
	MHKL2-20D	20	18		16	34	312	
	MHKL2-25D	25	22		19	41	562	
Single acting	normally open	MHKL2-12S	12		11	9	20	105
		MHKL2-16S	16		14	14.6	28.6	165
		MHKL2-20S	20		18	16	34	314
		MHKL2-25S	25		22	19	41	565
	normally closed	MHKL2-12C	12		11	9	20	105
		MHKL2-16C	16		14	14.6	28.6	165
		MHKL2-20C	20		18	16	34	314
		MHKL2-25C	25		22	19	41	565

Symbol

Double acting

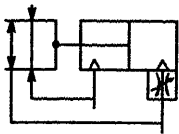

Single acting

Normally open

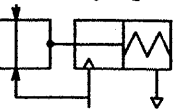

Normally closed

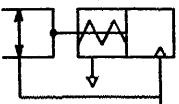

	Double acting	Single acting	
		Normally open	Normally closed
Fluid	Air		
Operating pressure	0.1~0.6MPa	0.25~0.6MPa	
Ambient and fluid temperature	-10~60°C		
Repeatability	±0.01		
Lubrication	Not required		
Auto switch (Optional)	Solid state switch (3-wire, 2-wire)		

2. Operating method

2-1 Environment

Warning

- ① Do not use in environment of corrosive grass, salt water, water, nor vapor.
- ② Do not use in direct sun light.
- ③ Do not subject to excessive vibration.
- ④ Do not use close to flame.
- ⑤ Use a cover when gripper must be used in an environment where dust or cutting oil will come in contact with gripper.
- ⑥ Consult SMC for the use in any other special environment.

2-2 Air source

Warning

- ① Use clean air.

Do not use compressed air contains chemicals, salinity, corrosive gas or synthetic oil with organic solvent. Using it may cause malfunction or damage of air gripper.

Caution

- ① Mount air filter.

Mount air filter near valve and before air gripper. Select filtration rating of $5 \mu\text{m}$ or less.

- ② Install after-cooler, air dryer and drain catch.

Compressed air contains a large amount of drain may cause malfunction of valve and other pneumatic equipment.

- ③ Use air gripper within the specified fluid and ambient temperature range.

If air gripper is used below 5°C , moisture inside the circuit is frozen and may cause damage of packings or malfunction.

Take preventative measures for freezing.

Refer to SMC "Compressed Air Cleaning System" for the details of compressed air quality described above.

2-3 Lubrication

⚠ Caution

- ① Non-lube type is lubricated already. Therefore, it is not necessary to lubricate before using. When lubricating the gripper, use the turbine oil class 1 (ISO VG32) and refuel continually. When lubrication has been started, it must be continued throughout the life of the gripper or malfunction may result.

2-4 Mounting

⚠ Warning

1. Do not drop nor dent the gripper when mounting. Slight deformation can cause unaccuracy or malfunction.
2. Tighten the screw within the specified torque range to mount the attachment. The tightening with larger torque than specified range may cause malfunction, while the tightening with smaller torque may allow movement of holding position and dropping of work.

How to mount the attachment on fingers

To mount attachment, screw bolts in finger mounting female threads with the tightening torque in the table below.

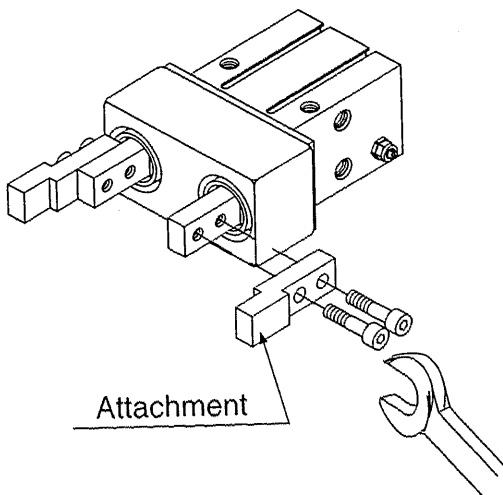

Model	Mounting bolt	Max. tightening Torque N·m
MHK2-12□ MHKL2-12□	M3 × 0.5	0.59
MHK2-16□ MHKL2-16□		
MHK2-20□ MHKL2-20□	M4 × 0.7	1.4
MHK2-25□ MHKL2-25□	M5 × 0.8	2.8

3. Adjust the holding point so that excessive force will not be applied on fingers when inserting the work.

Confirm that the gripper can operate without receiving any shock by testing with manual operation or low-speed operation.

Mounting of gripper

Axial mounting type (Body tapped)

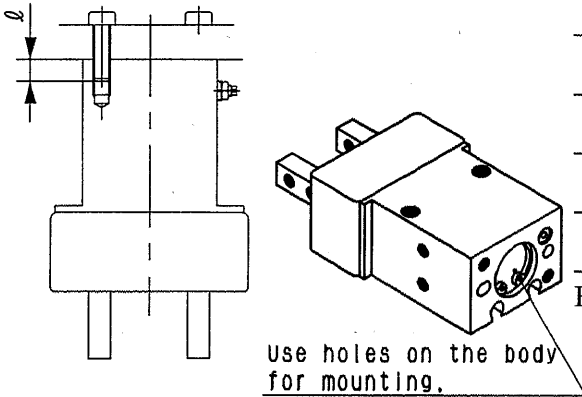

Model	mounting bolt	Max.tightening torque N · m	Max.screw-in depth (l mm)	Hole dia (mm)	hole depth (mm)
MHK2-12□ MHKL2-12□	M3×0.5	0.88	6	$\phi 13H9^{+0.043}_0$	1.5
MHK2-16□ MHKL2-16□	M4×0.7	2.1	8	$\phi 17H9^{+0.043}_0$	1.5
MHK2-20□ MHKL2-20□	M5×0.8	4.3	10	$\phi 21H9^{+0.052}_0$	1.5
MHK2-25□ MHKL2-25□	M6×1	7.3	12	$\phi 26H9^{+0.052}_0$	1.5

Refer to a catalog for location pin hole dimensions.

Length side mounting (Body tapped)

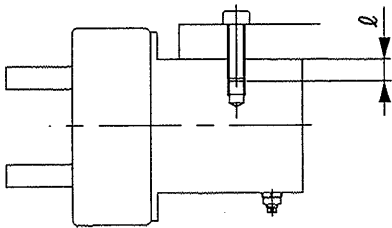

Model	mounting bolt	Max.tightening torque (N · m)	Max.screw-in depth (l mm)
MHK2-12□ MHKL2-12□	M3×0.5	0.59	4
		0.74	5
MHK2-16□ MHKL2-16□	M4×0.7	0.88	4
		1.3	5
MHK2-20□ MHKL2-20□	M5×0.8	3.3	8
MHK2-25□ MHKL2-25□	M6×1	5.9	10

Lateral side mounting (Body tapped)

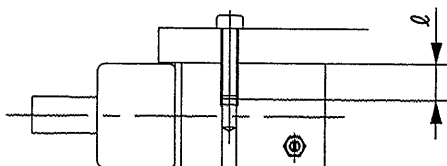

Model	mounting bolt	Max.tightening torque (N · m)	Max.screw-in depth (l mm)
MHK2-12□ MHKL2-12□	M4×0.7	2.1	8
MHK2-16□ MHKL2-16□			
MHK2-20□ MHKL2-20□	M5×0.8	4.3	10
MHK2-25□ MHKL2-25□	M6×1	7.3	12

Lateral side mounting (Through-hole mounting)

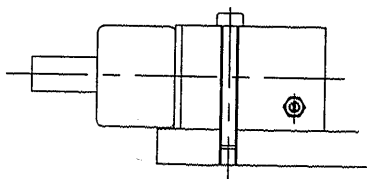

Model	mounting bolt	Max.tightening torque (N · m)
MHK2-12□ MHKL2-12□	M3×0.5	0.88
MHK2-16□ MHKL2-16□		
MHK2-20□ MHKL2-20□	M4×0.7	2.1
MHK2-25□ MHKL2-25□	M5×0.8	4.3

Caution

- ① Avoid the excessive force on fingers when mounting the attachment.
Any change of fingers may cause the malfunction and deteriorate the accuracy.
- ② Avoid external force to fingers. Fingers may be damaged by continual lateral or the impact load.

Provide clearance to prevent the work or the attachment from striking against any object at the stroke end.

1. Stroke end in finger opening condition

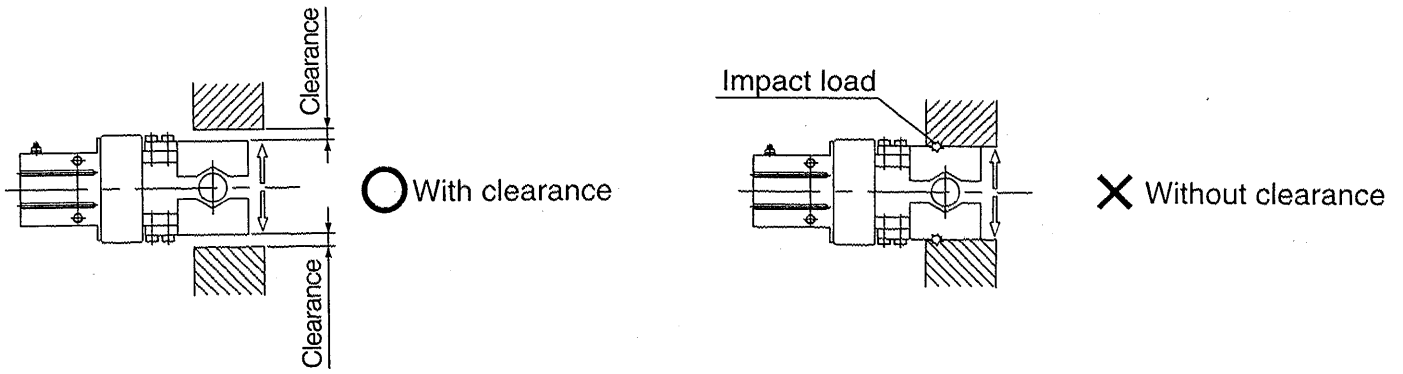

2. Air gripper traveling stroke end

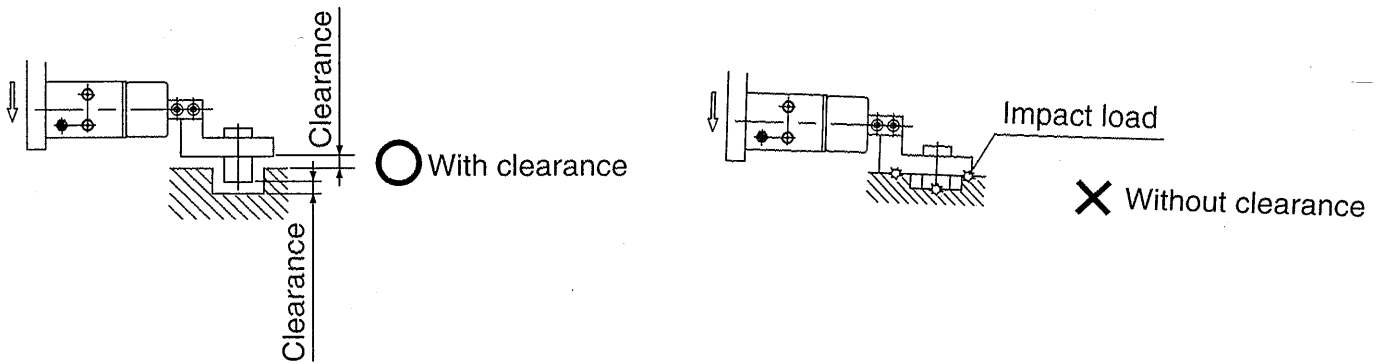

3. At opposite movement

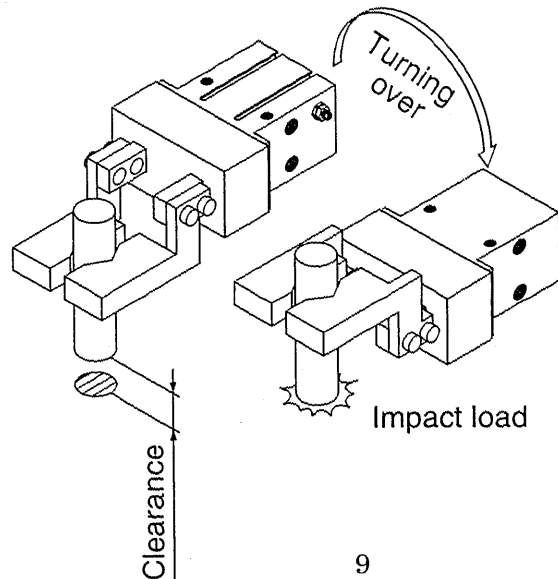

- ③ Adjust the holding point so that excessive force will not be applied on fingers when inserting the work.

Confirm that the gripper can operate without receiving any shock by testing with manual operation or low-speed operation.

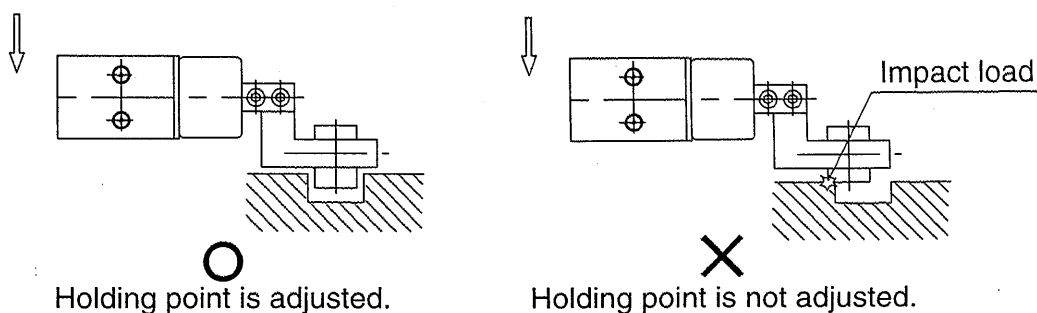

- ④ Adjust speed to open and close finger not to reach excessive speed.

If open-close speed is unnecessarily fast, impact force on finger becomes too great and will shorten its life.

Example of adjustment by SMC's speed controller.

Double acting type	Built-in needle with orifice inside is used for speed adjustment. Table below can be referred as a guide.
Single acting type	Connect speed controller to close side port of the finger and use it as meter-in style.

Applicable speed controller

Air gripper mounted type AS1200-M5
AS2200-01

In-Line type AS1000series
AS1001F, AS2051F

Model	Back turns from the needle fully closed. (※1)
MHK2-12D	3/4 ~ 1
MHK2-16D	1 ~ 1 1/4
MHK2-20D	1 1/2 ~ 1 3/4
MHK2-25D	1 3/4 ~ 2
MHKL2-12D	1 ~ 1 1/4
MHKL2-16D	1 1/4 ~ 1 1/2
MHKL2-20D	1 3/4 ~ 2
MHKL2-25D	2 ~ 2 1/4

(※ 1) When needle is tightened to slightly touch bottom.

2-5 Selection

⚠ Warning

- ① Keep the holding point within the specified range of the holding distance.
When the holding point distance becomes large, the finger attachment applies an excessively large load to the cross roller section, causing excessive play of the fingers and possibly leading to premature failure.

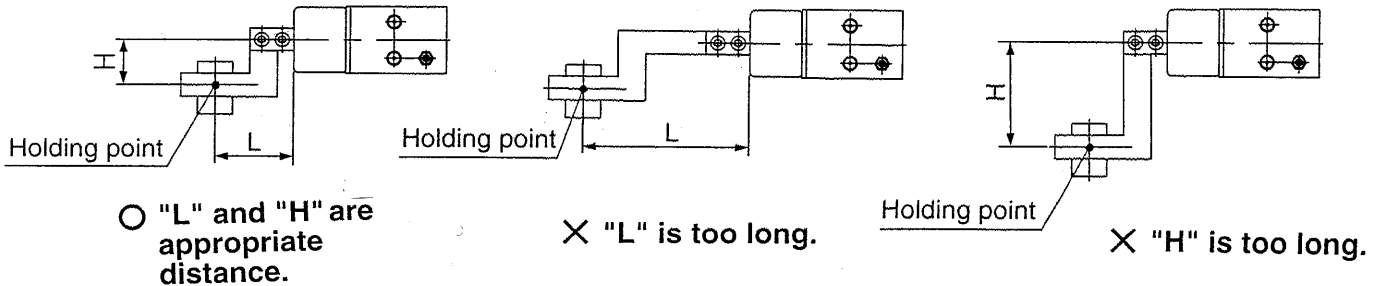

- ② For single acting type, keep the use within allowable moment referred to following table.
If moment illustrated below is given to finger, there is possibility that spring can't resist the moment and make finger return.

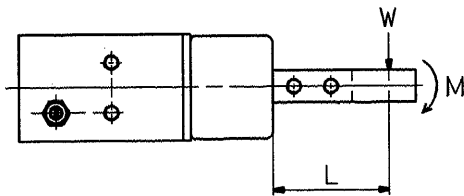

$M = \text{Allowable moment}$
($M = WL$)

Model	Allowable moment N·m
MHK2-12 S, C MHKL2-12 S, C	0.05
MHK2-16 S, C MHKL2-16 S, C	0.12
MHK2-20 S, C MHKL2-20 S, C	0.26
MHK2-25 S, C MHKL2-25 S, C	0.49

- ③ Attachment should be designed as light and short as possible.
1. Long and heavy attachment increases the inertia force to open or close the finger. It may cause unsteady movement of fingers and have an adverse effect on life.
 2. Even if holding point remains within the limited range, make the attachment as light and short as possible.

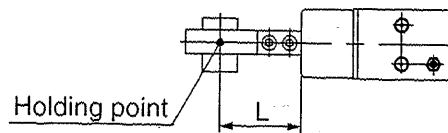

3. Please use some pieces or large size if long work or large work.

- ④ Please set roll on attachment if work is extra thin or extra fine.
Product without roll off may cause incorrect positioning or incorrect holding, due to unstable holding.

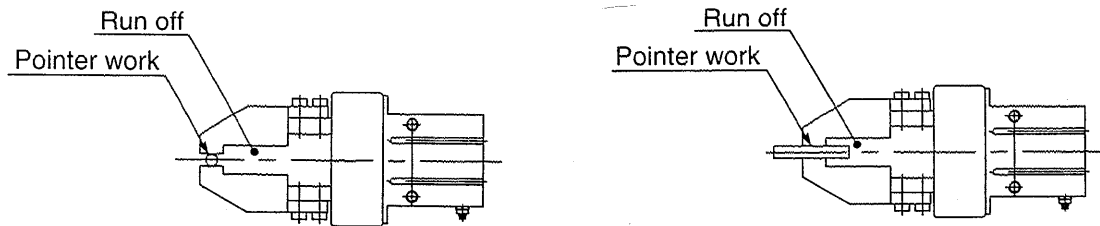

- ⑤ Select the model whose holding force is sufficient against work weight.
Incorrect selection may lead to release of work etc. Refer to “Effective holding force” and information to select the model by weight of work.
- ⑥ Do not use in applications where excessive external force or impact force may be applied to gripper. It may cause malfunction. Consult SMC with regard to any other application.
- ⑦ Select a model to have allowance in opening/closing width or work.
<If no allowance is provided>
1. Holding may be insecure due variations in air gripper opening/closing width or in work diameter.
 2. If auto-switch is used, detection failure may occur. Refer to hysteresis of auto-switch in each series to secure extra stroke for hysteresis. Especially when dual color advance waterproof auto-switch is used, stroke may be restricted depending on the setting of the lamp color at detection.

2-6 Installation and Setting of Auto Switch

① Auto switch can be used in various ways depending on the number installed and the required detecting position.

1) Detection of work (External holding)

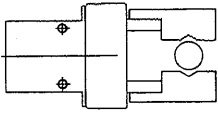
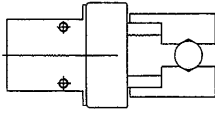
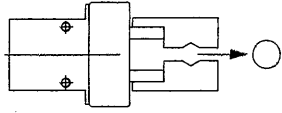
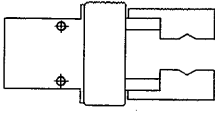
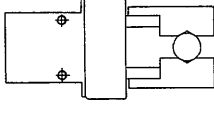
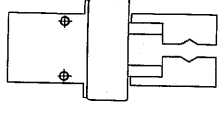
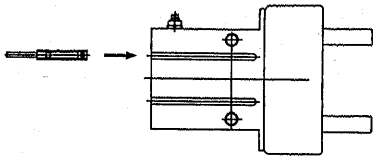
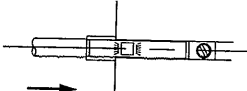
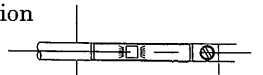
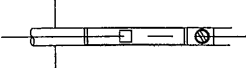
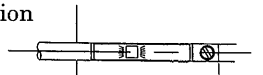
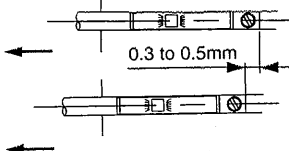
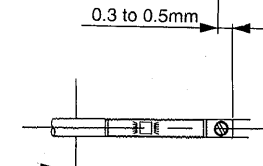
Detection example		①Confirmation of finger reset position.	②Confirmation of work holding	③Confirmation of work releasing
Detecting position		Fingers fully open position 	Work holding position 	Finger fully closed position 
Operation of auto switch		Switch ON at finger reset position (Light: ON)	Switch ON at work holding position (Light: ON)	At work holding position (Normal operation) : Switch OFF (Light: OFF) Work releasing condition (Abnormal operation) : Switch ON (Light: ON)
Combinations of detection	One Auto switch	●	●	●
	Two auto switches	●——●	●——●	●——●
Auto Switch mounting position /setting procedure		Procedure 1) Fully open the fingers. 	Procedure 1) Locate the fingers in the work holding position. 	Procedure 1) Locate the fingers in the Fully closed position. 
Connect a switch applying no or low voltage and follow the procedures for setting.		Procedure 2) Insert the auto switch mounting groove from the direction shown in the figure. 		
		Procedure 3) Slide auto switch in the direction of the arrow until the indicator light comes on. 	Procedure 3) Slide auto switch in the direction of the arrow until the indicator lights. Move switch a further 0.3 to 0.5mm in the direction of the arrow and set. 	
		Procedure 4) Slide the auto switch a further distance in the direction of the arrow until the indicator light goes out. 	Indicator lighting position 	
		Procedure 5) Move the auto switch in the opposite direction, as shown by the arrow, a distance of 0.3 to 0.5mm and set. 	Fitting position 	

Note) It is recommended that work be held at the center of the finger stroke.

If work is held around the end position of finger opening stroke, the above detecting combination may be limited due to the ON/OFF differential of the auto switches.

2) Detection of work (Internal holding)

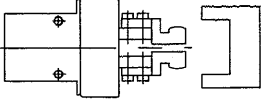
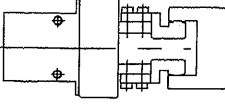
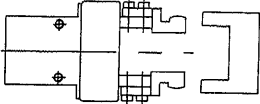
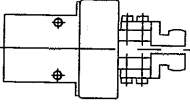
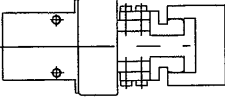
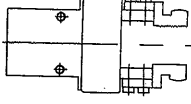
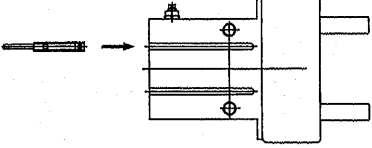
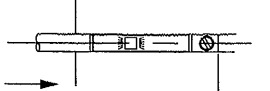
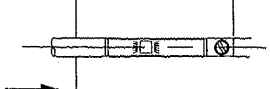
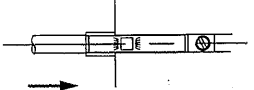
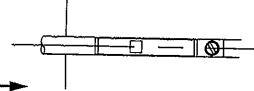
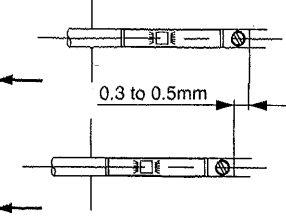
Detection example		①Confirmation of finger reset position.	②Confirmation of work holding	③Confirmation of work releasing
Detecting position		Fingers fully closed position 	Work holding position 	Finger fully open position 
Operation of auto switch		Switch ON at finger reset position (Light: ON)	Switch ON at work holding position (Light: ON)	At work holding position (Normal operation) : Switch OFF (Light: OFF) Work releasing condition (Abnormal operation) : Switch ON (Light: ON)
Combination of detection	One Auto switch	●	●	●
	Two auto switches	● ——— ●	● ——— ●	● ——— ●
		● ——— ●	● ——— ●	● ——— ●
Auto Switch mounting position /setting procedure		Procedure 1) Fully close the fingers. 	Procedure 1) Locate the fingers in the work holding position. 	Procedure 1) Locate the fingers in the fully open position. 
Connect a switch applying no or low voltage and follow the procedures for setting.		Procedure 2) Insert the auto switch installation groove from the direction shown in the following drawing. 		
		Procedure 3) Slide auto switch in the direction of the arrow until the indicator lights. Move switch a further 0.3 to 0.5mm in the direction of the arrow and set. Indicator lighting position  Fitting position  0.3 to 0.5mm	Procedure 3) Slide auto switch in the direction of the arrow until the indicator light comes on.  Procedure 4) Slide the auto switch a further distance in the direction of the arrow until the indicator light goes out.  Procedure 5) Move the auto switch in the opposite direction, as shown by the arrow, a distance of 0.3 to 0.5mm and set.  0.3 to 0.5mm	

Note) It is recommended that work be held at the center of the finger stroke.

It work is held around the end position of finger opening stroke, the above detecting combination may be limited due to the ON/OFF differential of the auto switches.

② Setting Method of Auto Switch

To set the auto switch, insert the auto switch into the switch groove of the air gripper from the direction indicated in the following drawing. After setting the position, tighten the attached switch mounting set screw with a straight bladed switchmakers screwdriver.

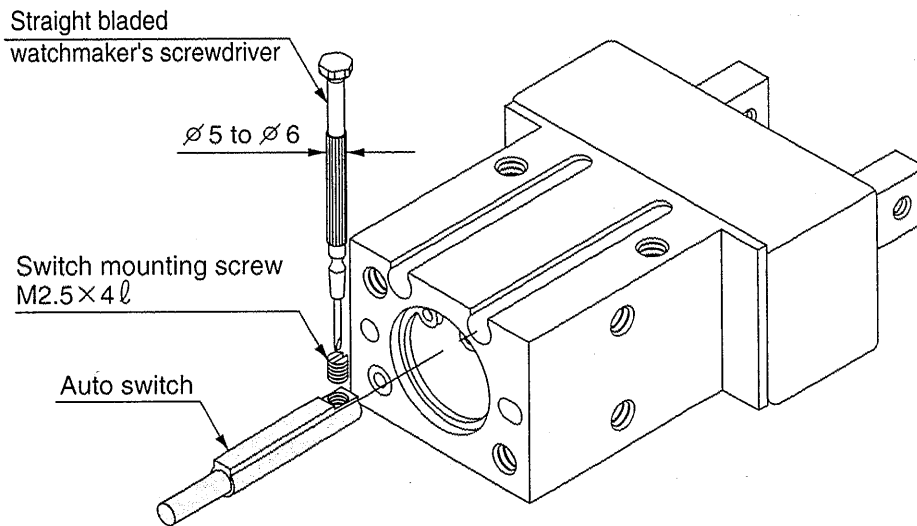

Note) Use a screwdriver with a grip diameter of 5 to 6mm to tighten the auto switch mounting screw. The tightening torque should be about 0.05 to 0.1 N·m. When you begin to feel that the screw is being tightened, turn it further by 90° .

③ Auto Switch Hysteresis

Similarly to micro switch, auto switch have hysteresis. The values in the following tables are criteria for switch position control etc.

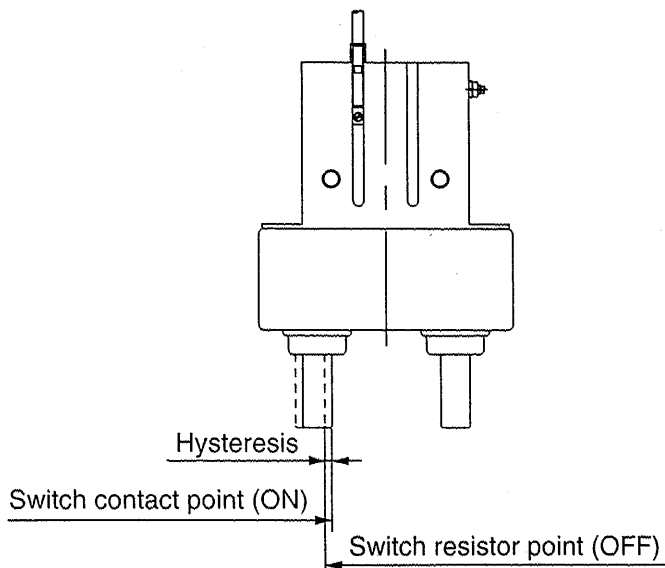

Auto Switch Model	Max. hysteresis mm		
	D-F9N(V) F9B(V)	D-F9BAL	
		ON : Red light emitting diode	ON : Green light emitting diode
MHK□2-12□	0.4	0.4	1.6
MHK□2-16□	0.4	0.4	1.6
MHK□2-20□	0.4	0.4	1.6
MHK□2-25□	0.4	0.4	1.6

④ Protrusion of Auto Switch from Edge of Body

The protrusion of an auto switch from the edge of the body in the table below.

Use the table as a guideline for mounting.

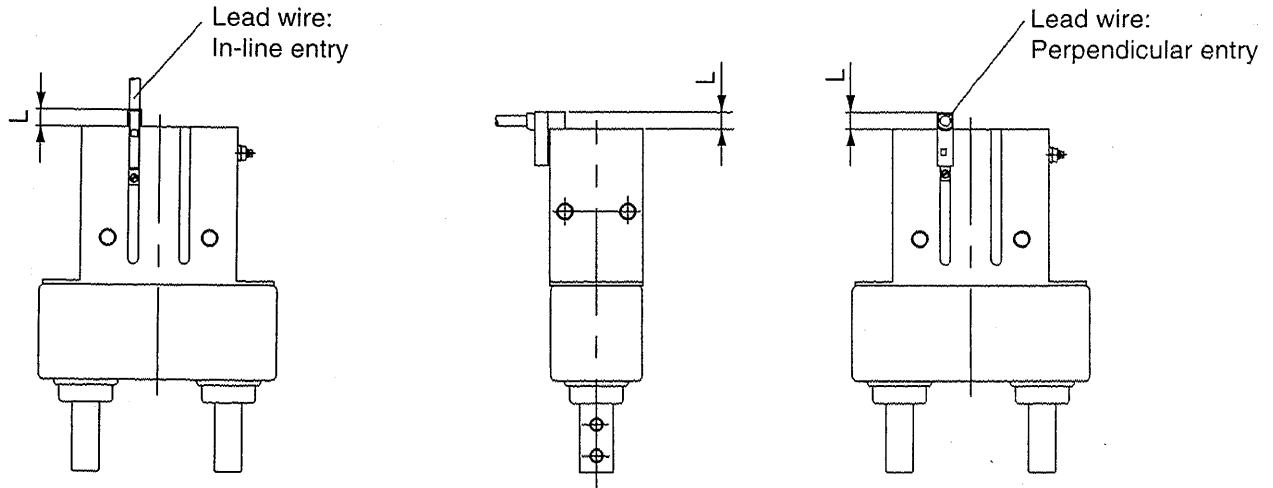

Unit : mm

Air gripper		Lead wire Auto switch finger position	In-line entry			Perpendicular entry	
			D-F9N	D-F9B	D-F9BA	D-F9NV	D-F9BV
MHK2-12□	Open	—	2	7	—	—	
	Closed	3	7	1 2	—	—	
MHK2-16□	Open	—	2	6	—	—	
	Closed	3	8	1 3	1	1	
MHK2-20□	Open	—	—	1	—	—	
	Closed	1	5	1 1	—	—	
MHK2-25□	Open	—	—	—	—	—	
	Closed	2	6	1 2	—	—	
MHKL2-12□	Open	—	—	3	—	—	
	Closed	3	7	1 2	—	—	
MHKL2-16□	Open	—	—	1	—	—	
	Closed	3	8	1 3	1	1	
MHKL2-20□	Open	—	—	—	—	—	
	Closed	1	6	1 1	—	—	
MHKL2-25□	Open	—	—	—	—	—	
	Closed	1	6	1 1	—	—	

⚠ Caution

When auto switch for MHK2, MHKL2 is set on mounting side as figure below, allow for at least 1mm on mounting plate since the auto switch is protruded from edge of gripper.

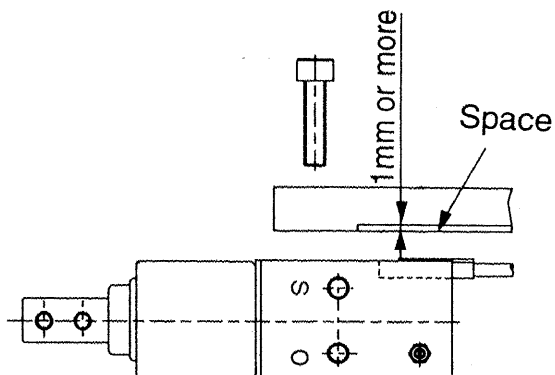

2-7 Piping

1. Preparation before piping

Thoroughly air blow (brushing) or clean to remove chips, cutting oil, and dust in the pipe.

2. How to wrap seal tape

When installing piping and fittings, care should be taken to avoid entering of chips from piping threads and seal materials into the product. In addition, when wrapping seal tape, please leave 1.5~2 threads uncovered on the pipe end.

3. Operating air

Air supplied to the cylinder should be filtered off by using SMC made AF series air filter, and operate pressure reduced air to the specified setting pressure by such as AR series regulator.

3 Maintenance

3-1 Notes

Warning

1. Do not enter the transfer line nor put the object. It may cause unexpected accidents.
2. Do not enter your hands between finger and attachment. It may cause unexpected accidents.
3. Confirm that no work is held by fingers before releasing the compressed air to remove the gripper from the line.
4. Dropping of work can be dangerous.

3-2 Structural drawing / Parts List

Double acting/Finger open condition

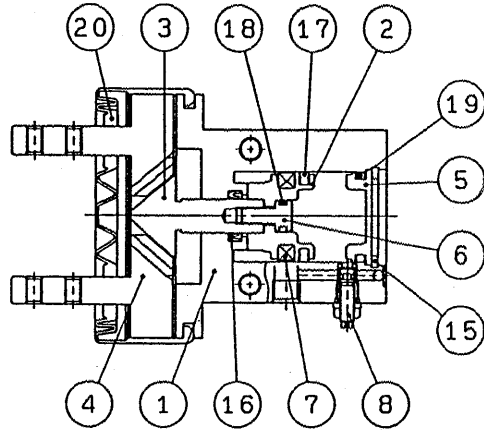

Single acting/Normally open

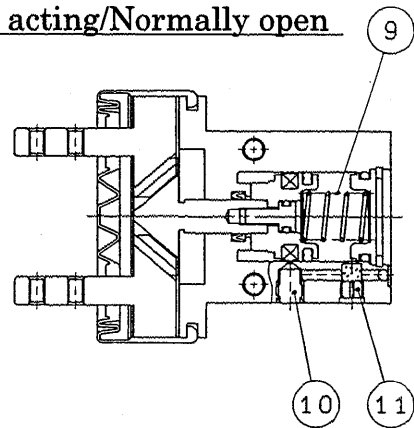

Double acting/Finger closed condition

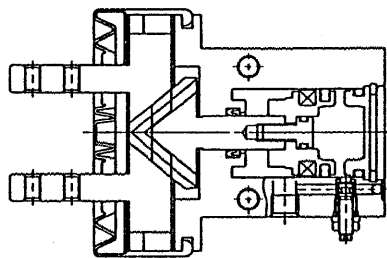

Single acting/Normally closed

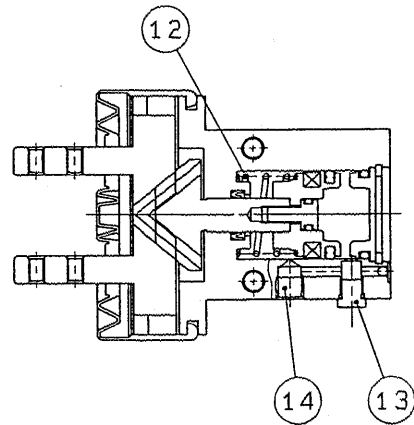

Parts List

No.	Description	Material	Note
1	Body	Aluminum alloy	Hard anodized
2	Piston	Aluminum alloy	Hard anodized
3	Cam	Carbon steel	Heat treatment, Special treatment
4	Finger	Carbon steel	Heat treatment, Special treatment
		Stainless steel SUS 304	Optional
5	Cap	Aluminum alloy	Hard anodized
6	Piston bolt	Stainless steel	

No.	Description	Material	Note
7	Rubber magnet	Synthetic rubber	
8	Needle Ass'y		
9	N.O. spring	Piano wire	
10	Plug	Brass	Electroless nicke plated
11	Exhaust plug	Brass	Electroless nicke plated
12	N.C. spring	Piano wire	
13	Plug Ass'y	Brass	Electroless nicke plated
14	Exhaust plug A	Brass	Electroless nicke plated
15	Retaining ring C	Carbon steel	Nickel plated

Seals List

No.	Description	Material	Part No.							
			MHK2-12□	MHKL2-12□	MHK2-16□	MHKL2-16□	MHK2-20□	MHKL2-20□	MHK2-25□	MHKL2-25□
16	Packing set	NBR	MHK12-PS		MHK16-PS		MHK20-PS		MHK25-PS	
17										
18										
19										
20	Dust cover	*2) CR	P3318105	P3318113	P3318205	P3318213	P3318305	P3318313	P3318405	P3318413
		*2) FKM	P3318105-1	P3318113-1	P3318205-1	P3318213-1	P3318305-1	P3318313-1	P3318405-1	P3318413-1
		*2) Si	P3318105-2	P3318113-2	P3318205-2	P3318213-2	P3318305-2	P3318313-2	P3318405-2	P3318413-2

Note 1) No.16 to 19 is supplied in one unit for packing set. Designate the part number for each bore size when ordering.

Note 2) CR: Chloroprene rubber, FKM: Fluoro rubber, Si: Silicon rubber.

3-3 Replacing Procedure of Piston Ass'y

1. Remove Retaining ring C and cap using special jig.

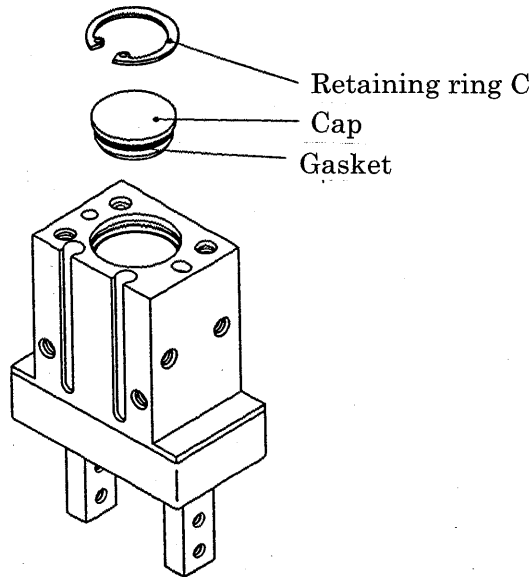

2. Unfasten piston bolt.

Hexagonal wrench size

ϕ 12	2.5
ϕ 16	2.5
ϕ 20	2.5
ϕ 25	4

3. Take out piston assembly and then replace packing.

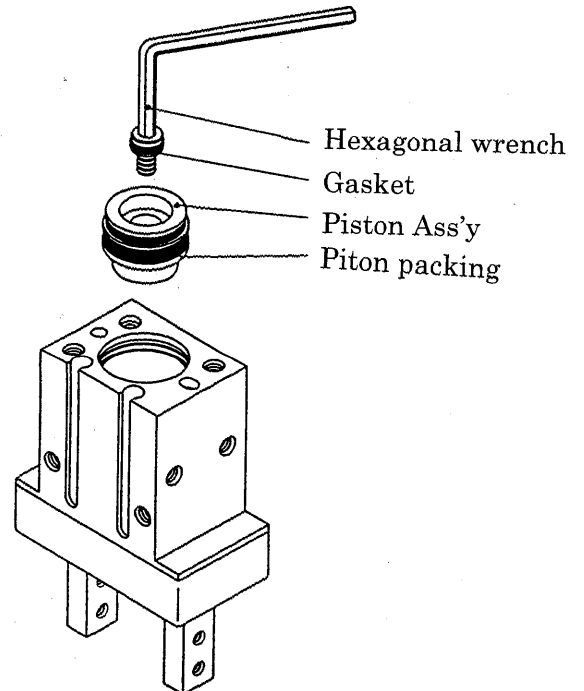

4. Follow this procedure backward for assembly.

Tightening Torque

(N·m)

ϕ 12	0.9
ϕ 16	0.9
ϕ 20	0.9
ϕ 25	4.2

- Contact SMC for grease : Special grease is available.