

# OPERATION MANUAL

PRODUCT NAME: MHZL2 SERIES

MODEL : MHZL2-10

MHZL2-16

MHZL2-20

MHZL2-25

- Read this operation manual carefully to understand before installation and operation.
- Pay extra attention on the clause concerning the safety.
- Keep this operation manual available whenever necessary.

# Contents

## 1. Specifications

## 2. Operating method

2 - 1. Precautions on design

2 - 2. Selection

2 - 3. Mounting

2 - 4. Air source

2 - 5. Piping

2 - 6. Environment

2 - 7. Lubrication

## 3. Maintenance

3 - 1. Notes

3 - 2. Exploded view



3 - 3. Replacing Procedure of Packing

3 - 4. Structural drawing / Parts List • Seal Kits

## Notes to users

### Safety Instructions

These safety instructions are intended to prevent a hazardous situation and/or equipment damage. These instructions indicate the level of potential hazard by label of “Caution”, “Warning”, or “Danger”. To ensure safety, be sure to observe ISO 4414<sup>Note 1)</sup>, JIS B 8370<sup>Note 2)</sup> and other safety practices.

- |  |
|--|
|  <b>Caution</b> : Operator error could result in injury or equipment damage.                          |
|  <b>Warning</b> : Operator error could result in serious injury or loss of life.                      |
|  <b>Danger</b> : In extreme conditions, there is a possible result of serious injury or loss of life. |

(Note – 1) ISO 4414 : Pneumatic fluid power – Recommendations for the application of equipment to transmission and control systems.

(Note – 2) JIS B 8370 : Pneumatic systems axiom.



### WARNING

- |  |
|--|
| <p>① <u>The compatibility of pneumatic equipment is the responsibility of the person who designs the pneumatic system or decides its specifications.</u></p> <p>Since the products specified here are used in various operating conditions, their compatibility for the specific pneumatic system must be based on specifications or after analyses and/or tests to meet your specific requirements.</p> <p>② <u>Only trained personnel should operate pneumatically operated machinery and equipment.</u></p> <p>Compressed air can be dangerous if an operator is unfamiliar with it. Assembly, handling or repair of pneumatic systems should be performed by trained and experienced operators.</p> <p>③ <u>Do not service machinery/equipment or attempt to remove component until safety is confirmed.</u></p> <ol style="list-style-type: none"><li>1. Inspection and maintenance of machinery/equipment should only be performed after confirmation of safe locked – out control positions.</li><li>2. When equipment is to be removed, confirm the safety process as mentioned above. Cut the supply pressure for this equipment and exhaust all residual compressed air in the system.</li></ol> |
|--|

3. Before machinery/equipment is re-started, take measures to prevent shooting out of cylinder piston rod etc. (Bleed air into the system gradually to create back-pressure. )

④ Contact SMC if the product is to be used in any of the following conditions :

1. Conditions and environments beyond the given specifications, or if product is used outdoors.
2. Installation on equipment in conjunction with atomic energy, railway, air navigation, vehicles, medical equipment, food and beverage, recreation equipment, emergency stop circuits, press applications, or safety equipment.
3. An application which has the possibility of having negative effects on people, property, or animals, requiring special safety analysis.

# 1. Specifications

## Specifications

Model		MHZL2-10	MHZL2-16	MHZL2-20	MHZL2-25	
Bore size mm		10	16	20	25	
Fluid		Air				
Operating pressure MPa	* <sup>1</sup> )D	0.2to0.7	0.1to0.7			
	* <sup>2</sup> )S • * <sup>3</sup> )C	0.35to0.7	0. 25to0.7			
Ambient and fluid temperature		- 10to60°C				
Repeatability		± 0.01 mm				
Max. operating frequency		120 c.p.m.				
Lubrication		Not required				
Action		Double acting, Single acting				
Holding force Per 1 finger	* <sup>1</sup> )D	External folding force	11	34	42	65
		Internal folding force	17	45	66	104
Persecution Value N	* <sup>2</sup> )S	External folding force	7.1	27	33	50
	* <sup>3</sup> )C	Internal folding force	13	38	57	85
Opening stroke mm		8	12	18	22	
Note1)Weight g	* <sup>1</sup> )D	60	135	270	470	
	* <sup>2</sup> )S	70	145	290	515	
	* <sup>3</sup> )C		140			

Note 1) Not including auto switch.

\*<sup>1</sup>) D; Double acting

\*<sup>2</sup>) S; Single acting(N.O)

\*<sup>3</sup>) C; Single acting(N.C)

## 2. Operation Guide for Air Gripper.

### 2-1 Precautions on design

#### ⚠ Warning

1. A protective cover is recommended to minimize the risk of personal injury due to accidental contact with moving parts of the gripper.
2. Measures should be taken to protect against unexpected drop of work due to loss of air pressure.
3. Contact SMC for other applications than work transfer. (i.e. Positioning, crimping)

### 2-2 Selection

#### ⚠ Warning

1. Keep the holding point within the specified range of the holding distance.

When the holding point distance becomes large, the finger attachment applies an excessively large load to the cross roller section, causing excessive play of the fingers and possibly leading to premature failure. Refer to catalog for details.

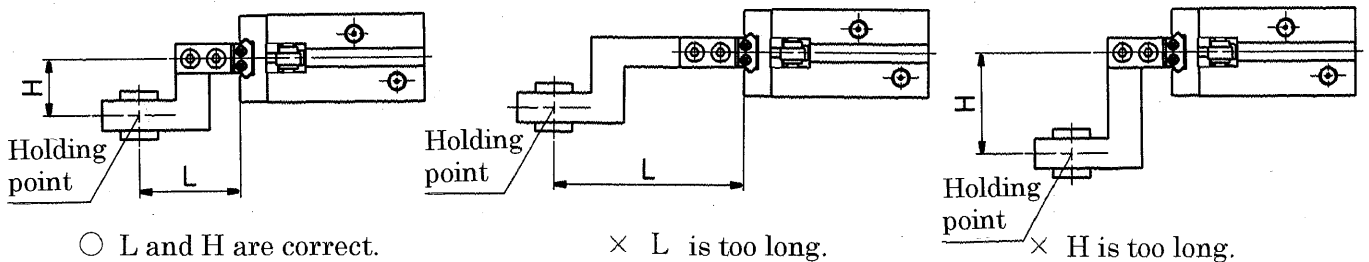

2. Attachment should be designed as light and short as possible.

- 1) Long and heavy attachment increases the inertia force to open or close the finger. It may cause unsteady movement of fingers and have an adverse effect on life.
- 2) Even if holding point remains within the limited range, make the attachment as light and short as possible. Refer to catalog for details.

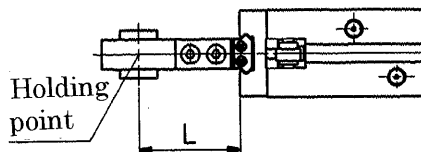

- 3) Please use some pieces or larger size if long work or large work.

3. Please set roll on attachment if work is extra thin or extra fine.

Product without roll off may cause incorrect positioning or incorrect holding, due to unstable holding.

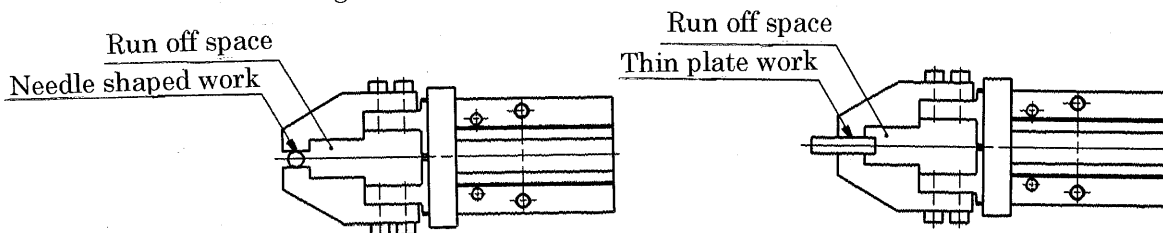

4. Select the model whose holding force is sufficient against work weight.  
Incorrect selection may lead to release of work etc. Refer to “Effective holding force” and information to select the model by weight of work.
5. Do not use in applications where excessive external force or impact force may be applied to gripper. It may cause malfunction. Consult SMC with regard to any other application.
6. Select a model to have allowance in opening/closing width to work.  
< If no allowance is provided >
  - 1) Holding may be insecure due variations in air gripper opening/closing width or in work diameter.
  - 2) If auto-switch is used, detection failure may occur. Refer to hysteresis of auto-switch in each series to secure extra stroke for hysteresis. Especially when dual color advance waterproof auto-switch is used, stroke may be restricted depending on the setting of the lamp color at detection.
7. Please tell us when holding with spring force alone on single type.  
It may cause returning failure or unstable holding, due to operating failure.

## 2-3 Mounting

### Warning

1. Do not drop nor dent the gripper when mounting. Slight deformation can cause unaccuracy or malfunction.
2. Tighten the screw within the specified torque range to mount the attachment.  
The tightening with larger torque than specified range may cause malfunction, while the tightening with smaller torque may allow movement of holding position and dropping of work.

#### How to mount the attachment on fingers

To mount attachment, screw bolts in finger mounting female threads with the tightening torque in the table below.

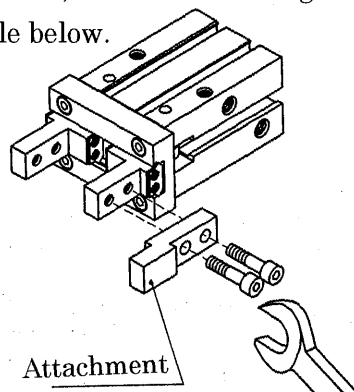

Model	mounting bolt	Max.tightening torque N · m
MHZL2-10	M2.5×0.45	0.31
MHZL2-16	M3×0.5	0.59
MHZL2-20	M4×0.7	1.4
MHZL2-25	M5×0.8	2.8

3. Adjust the holding point so that excessive force will not be applied on fingers when inserting the work.  
Confirm that the gripper can operate without receiving any shock by testing with manual operation or low-speed operation.

## Mounting of gripper

### Axial mounting type (Body tapped)

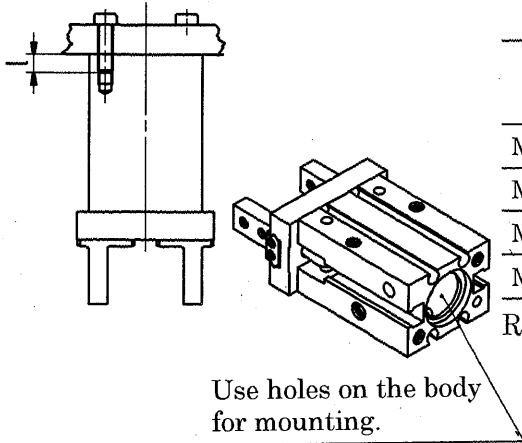

Model	mounting volt	Max.tightening torque N · m	Max.screw- in depth (mm)	Hole dia (mm)	hole depth (mm)
MHZZL2-10	M3×0.5	0.88	6	φ 11H9 <sup>+0.043</sup> <sub>0</sub>	2
MHZZL2-16	M4×0.7	2.1	8	φ 17H9 <sup>+0.043</sup> <sub>0</sub>	2
MHZZL2-20	M5×0.8	4.3	10	φ 21H9 <sup>+0.052</sup> <sub>0</sub>	3
MHZZL2-25	M6×1	7.3	12	φ 26H9 <sup>+0.052</sup> <sub>0</sub>	3.5

Refer to a catalog for location pin hole dimensions.

### Length side mounting (Body tapped)

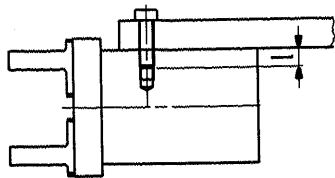

Model	mounting volt	Max.tightening torque N · m	Max.screw- in depth (mm)
MHZZL2-10	M3×0.5	0.9	6
MHZZL2-16	M4×0.7	1.6	4.5
MHZZL2-20	M5×0.8	3.3	8
MHZZL2-25	M6×1	5.9	10

### Lateral side mounting (Body tapped)

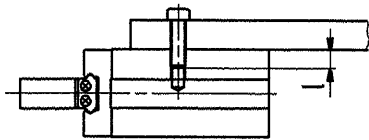

Model	mounting volt	Max.tightening torque N · m	Max.screw- in depth (mm)
MHZZL2-10	M3×0.5	0.69	5
MHZZL2-16	M4×0.7	2.1	8
MHZZL2-20	M5×0.8	4.3	10
MHZZL2-25	M6×1	7.3	12

### Lateral side mounting (Through-hole mounting)

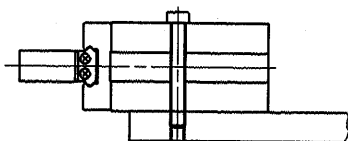

Model	mounting volt	Max.tightening torque N · m	Max.screw- in depth (mm)
MHZZL2-10	M2.5×0.45	0.49	5
MHZZL2-16	M3×0.5	0.88	8
MHZZL2-20	M4×0.7	2.1	10
MHZZL2-25	M5×0.8	4.3	12

Note) D-Y59type, D-Y69type, D-Y7type auto-switch usage are limited for body tap type. Make screw-in depth ≤ above table, not to push switch by end of bolt.



## ⚠ Caution

1. Avoid the excessive force on fingers when mounting the attachment.  
Any change of fingers may cause the malfunction and deteriorate the accuracy.
2. Avoid external force to fingers. Fingers may be damaged by continual lateral or the impact load.  
Provide clearance to prevent the work or the attachment from striking against any object at the stroke end.

### 1. Stroke end in finger opening condition

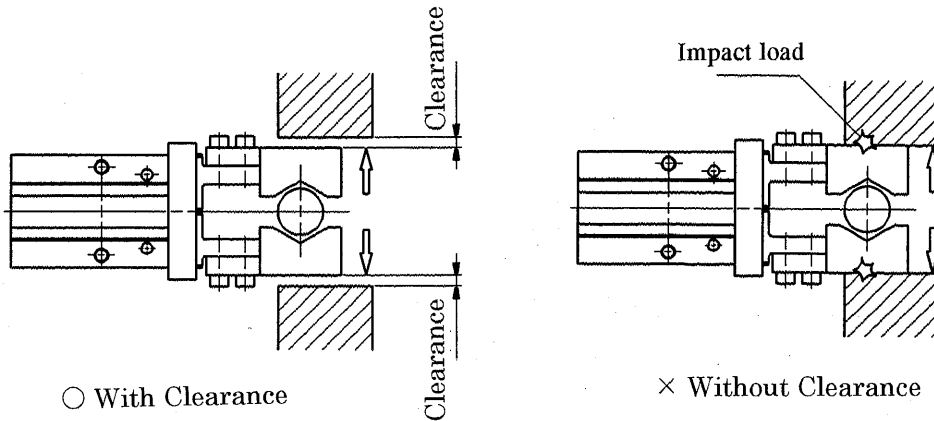

### 2. Air gripper traveling stroke end

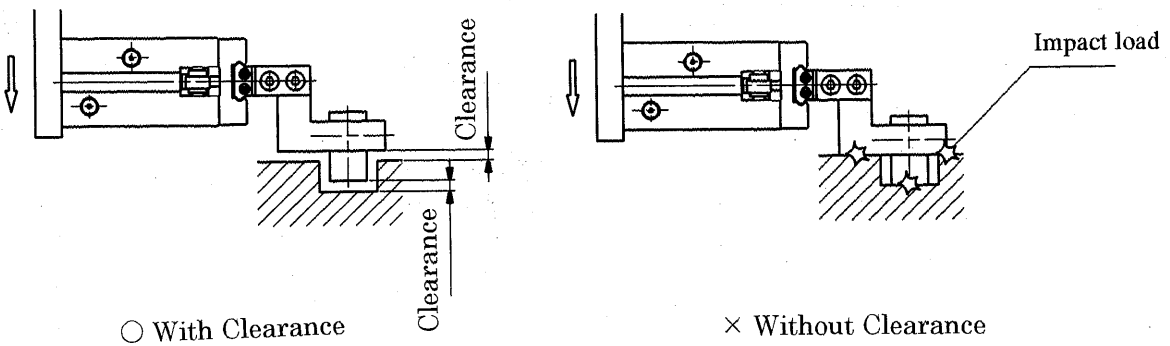

### 3. At opposite movement

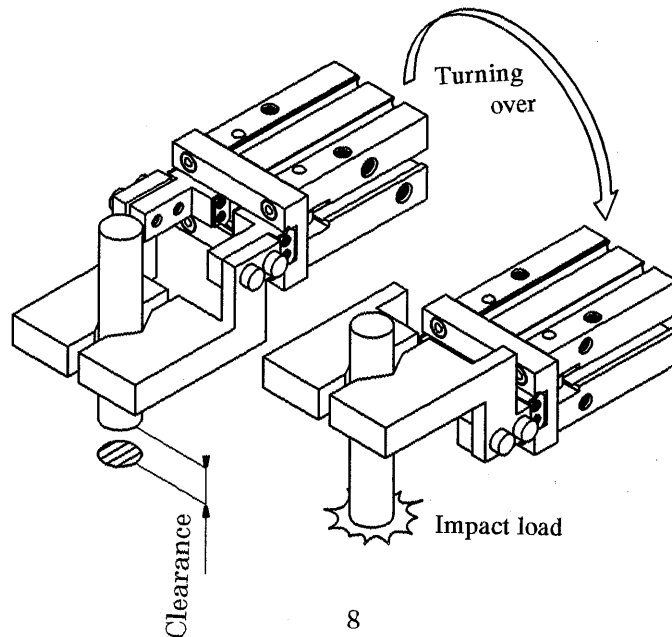

- Adjust the holding point so that excessive force will not be applied on fingers when inserting the work.

Confirm that the gripper can operate without receiving any shock by testing with manual operation or low-speed operation.

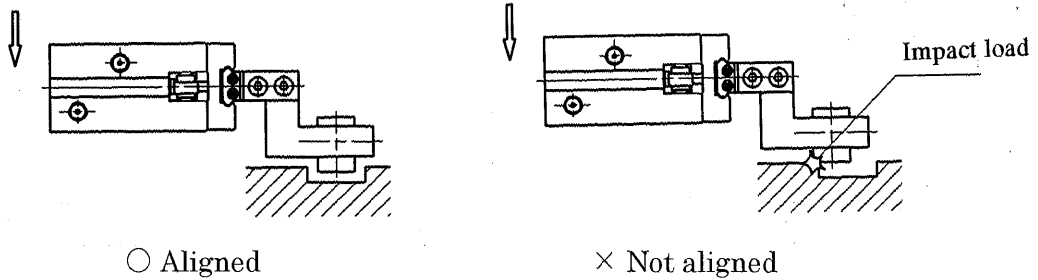

- Excessive finger opening/closing speed may cause play or damage of air gripper due to inertia of fingers or attachment. Mount speed controller to avoid impact.

Applicable speed controller

- Air gripper mounted type ..... AS1200-M5  
AS2200-01
- In-Line type ..... AS1000series  
AS1001F, AS2051F

## 2-4 Air source

### ⚠ Warning

- Use clean air.

Do not use compressed air contains chemicals, salinity, corrosive gas or synthetic oil with organic solvent. Using it may cause malfunction or damage of air gripper.

### ⚠ Caution

- Mount air filter.

Mount air filter near valve and before air gripper. Select filtration rating of  $5\ \mu\text{m}$  or less.

- Install after-cooler, air dryer and drain catch.

Compressed air contains a large amount of drain may cause malfunction of valve and other pneumatic equipment.

- Use air gripper within the specified fluid and ambient temperature range.

If air gripper is used below  $5^\circ\text{C}$ , moisture inside the circuit is frozen and may cause damage of packings or malfunction. Take preventative measures for freezing.

Refer to SMC "Compressed Air Cleaning System" for the details of compressed air quality described above.

## 2-5 Piping

### Caution

1. Preparation before piping.

Thoroughly flush the fittings to prevent dust or chips from entering the gripper.

## 2-6 Environment

### Warning

1. Do not use in environment of corrosive grass, salt water, water, nor vapor.
2. Do not use in direct sun light.
3. Do not subject to excessive vibration.
4. Do not use close to flame.
5. Use a cover when gripper must be used in an environment where dust or cutting oil will come in contact with gripper.
6. Consult SMC for the use in any other special environment.

## 2-7 Lubrication

### Caution

1. Non-lube type is lubricated already. Therefore, it is not necessary to lubricate before using. When lubricating the gripper, use the turbine oil class 1 (ISO VG32) and refuel continually. When lubrication has been started, it must be continued throughout the life of the gripper or malfunction may result.

## 3. Maintenance

### 3-1 Notes

#### Warning

1. Do not enter the transfer line nor put the object. It may cause unexpected accidents.
2. Do not enter your hands between finger and attachment. It may cause unexpected accidents.
3. Confirm that no work is held by fingers before releasing the compressed air to remove the gripper from the line. Dropping of work can be dangerous.

3-2 Exploded view

Finger Ass'y No.	
Ø10	MHZL-A1002
Ø16	MHZL-A1602
Ø20	MHZL-A2002
Ø25	MHZL-A2502

Finger Ass'y

Guide bolt

Tightening torque	
Ø10	0.15N·m
Ø16	0.31N·m
Ø20	0.59N·m
Ø25	1.37N·m

Anaerobic adhesive

Body Ass'y

Hexagon socket set screw

Body Ass'y	
Ø10	MHZL-A1001
Ø16	MHZL-A1601
Ø20	MHZL-A2001
Ø25	MHZL-A2501

Tightening torque	
Ø10	0.15N·m
Ø16	0.31N·m
Ø20	0.59N·m
Ø25	1.37N·m

Anaerobic adhesive

Piston Ass'y

Piston Ass'y	
Ø10	MHZL-A1003
Ø16	MHZL-A1603
Ø20	MHZL-A2003
Ø25	MHZL-A2503

Cap Ass'y

Retaining ring type C

### 3-3 Replacing Procedure of Packing

1. Remove C-shaped snap ring and cap using special jig.

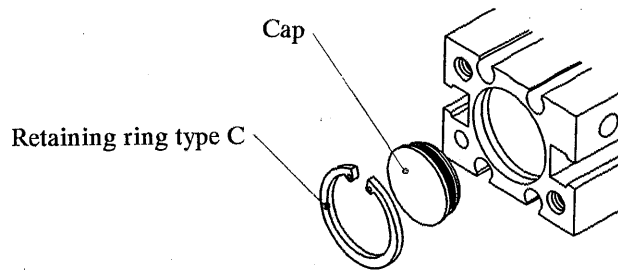

2. Unfasten guide bolt, remove guide.

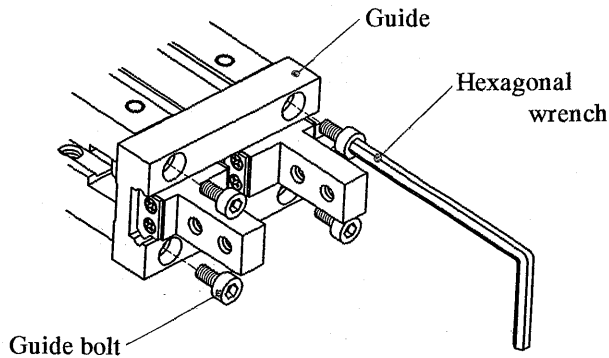

Hexagonal wrench size

$\phi 10$	1.5
$\phi 16$	2
$\phi 20$	2.5
$\phi 25$	3

3. Unfasten hexagon socket head cap screw, draw lever shaft, remove lever.

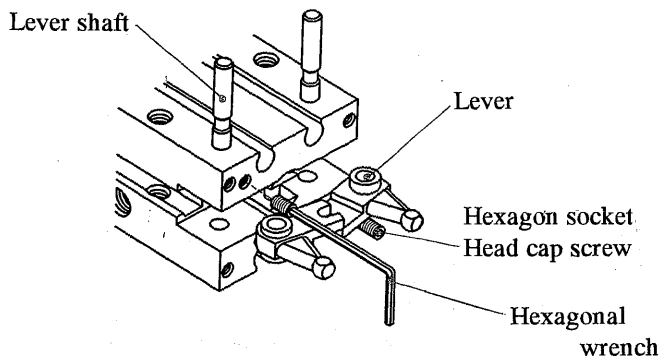

Hexagonal wrench size

$\phi 10$	0.9
$\phi 16$	1.3
$\phi 20$	1.5
$\phi 25$	2

4. Take out piston assembly and then replace packing.

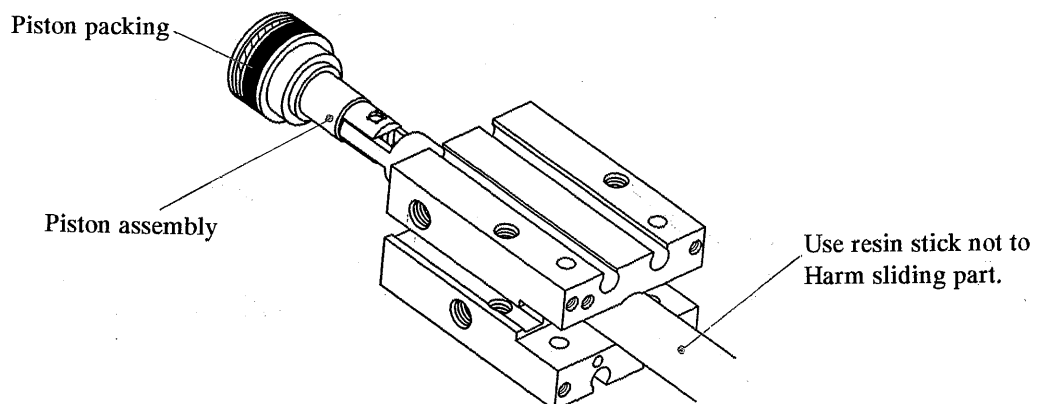

- Follow this procedure backward for assembly.
- Refer to the disassembly drawing for piston bolt tightening torque.
- Contact SMC for grease. Special grease is available.

### 3-4 Structural drawing / Parts List • Seal Kits

Double acting/Finger open condition      Single acting/Normally open

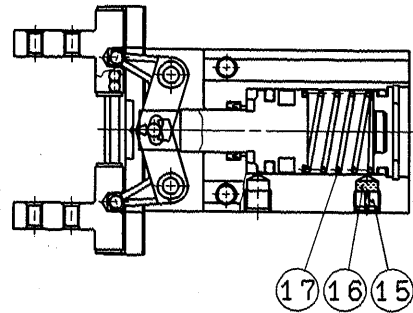
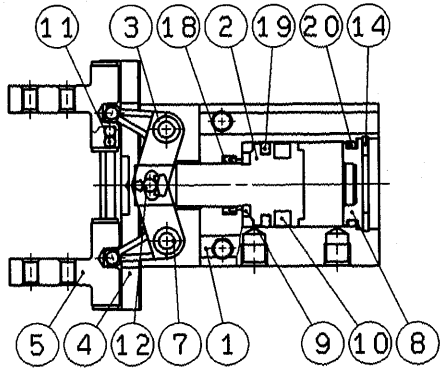

Single acting/Normally closed

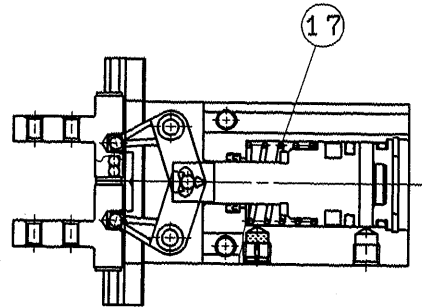
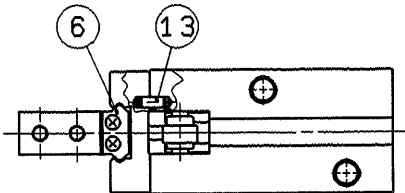

Double acting/Finger closed condition

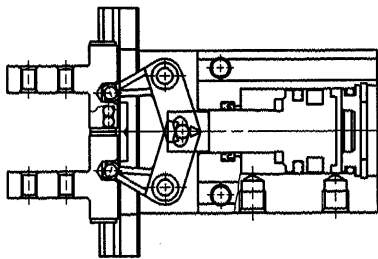

#### Parts List

No.	Description	Material	Note
1	Body	Aluminum alloy	Hard anodized
2	Piston	φ 10-16;Stainless steel φ 20-25;Aluminum alloy	φ 20-25 ; Hard anodized
3	Lever	Stainless steel	Heat treatment
4	Guide	Stainless steel	Heat treatment
5	Finger	Stainless steel	Heat treatment
6	Roller stopper	Stainless steel	
7	Lever shaft	Stainless steel	Nitrided
8	Cap	Aluminum alloy	Hard anodized
9	Dumper	Urethane rubber	
10	Rubber magnet	Synthetic rubber	

No.	Description	Material	Note
11	Steel ball	Steel	
12	Needle roller	Steel	
13	Parallel pin	Stainless steel	
14	Retaining ring C	Steel	Nickel plated
15	Exhaust plug A	Brass	Electroless nickel plated
16	Exhaust filter A	Polyvinyl formal	
17	Spring	Stainless steel wire	
18	Rod packing	NBR	
19	Piston packing	NBR	
20	Gasket	NBR	

#### Replaceable Parts List : Seal Kits

Part No.				Description
MHZL2-10	MHZL2-16	MHZL2-20	MHZL2-25	Kits include items 18,19 and 20 from the table above
MHZL10-PS	MHZL16-PS	MHZL20-PS	MHZL25-PS	

\*Seal kits consist of items 18,19 and 20 contained in one kit, and can be ordered using the order number for each respective cylinder bore size.