



Operation Manual

PRODUCT NAME

Mechanically jointed rodless cylinder
With cam follower guide,
With single-axis linear guide
With double-axis linear guide

MODEL / Series / Product Number

MY2C/H/HT Series

SMC Corporation

Contents

Safety Instructions ----- P. 2 to 3

1. Product Specifications

1.1 Specifications ----- P. 4

2. Operation and Mounting

2.1 Air Supply ----- P. 5

2.2 Operating Environment ----- P. 6

2.3 Design ----- P. 6

2.4 Mounting and Installation ----- P. 8

2.5 Piping ----- P. 10

2.6 Speed Control ----- P. 11

2.7 Shock Absorbing Mechanism ----- P. 11

2.8 Directional Control ----- P. 12

2.9 Mounting of Auto Switch ----- P. 13

3. Maintenance and Inspection

3.1 Inspection ----- P. 14

3.2 Maintenance ----- P. 14

3.3 Replacement Parts ----- P. 14

4. Troubleshooting

----- P. 15



Safety Instructions

These safety instructions are intended to prevent hazardous situations and/or equipment damage. These instructions indicate the level of potential hazard with the labels of "Caution," "Warning" or "Danger." They are all important notes for safety and must be followed in addition to International Standards (ISO/IEC)^{*1)}, and other safety regulations.

*1) ISO 4414: Pneumatic fluid power -- General rules relating to systems.

ISO 4413: Hydraulic fluid power -- General rules relating to systems.

IEC 60204-1: Safety of machinery -- Electrical equipment of machines .(Part 1: General requirements)

ISO 10218-1992: Manipulating industrial robots -Safety.

etc.



Caution

Caution indicates a hazard with a low level of risk which, if not avoided, could result in minor or moderate injury.



Warning

Warning indicates a hazard with a medium level of risk which, if not avoided, could result in death or serious injury.



Danger

Danger indicates a hazard with a high level of risk which, if not avoided, will result in death or serious injury.

Warning

1. The compatibility of the product is the responsibility of the person who designs the equipment or decides its specifications.

Since the product specified here is used under various operating conditions, its compatibility with specific equipment must be decided by the person who designs the equipment or decides its specifications based on necessary analysis and test results.

The expected performance and safety assurance of the equipment will be the responsibility of the person who has determined its compatibility with the product.

This person should also continuously review all specifications of the product referring to its latest catalog information, with a view to giving due consideration to any possibility of equipment failure when configuring the equipment.

2. Only personnel with appropriate training should operate machinery and equipment.

The product specified here may become unsafe if handled incorrectly.

The assembly, operation and maintenance of machines or equipment including our products must be performed by an operator who is appropriately trained and experienced.

3. Do not service or attempt to remove product and machinery/equipment until safety is confirmed.

1. The inspection and maintenance of machinery/equipment should only be performed after measures to prevent falling or runaway of the driven objects have been confirmed.

2. When the product is to be removed, confirm that the safety measures as mentioned above are implemented and the power from any appropriate source is cut, and read and understand the specific product precautions of all relevant products carefully.

3. Before machinery/equipment is restarted, take measures to prevent unexpected operation and malfunction.

4. Contact SMC beforehand and take special consideration of safety measures if the product is to be used in any of the following conditions.

1. Conditions and environments outside of the given specifications, or use outdoors or in a place exposed to direct sunlight.

2. Installation on equipment in conjunction with atomic energy, railways, air navigation, space, shipping, vehicles, military, medical treatment, combustion and recreation, or equipment in contact with food and beverages, emergency stop circuits, clutch and brake circuits in press applications, safety equipment or other applications unsuitable for the standard specifications described in the product catalog.

3. An application which could have negative effects on people, property, or animals requiring special safety analysis.

4. Use in an interlock circuit, which requires the provision of double interlock for possible failure by using a mechanical protective function, and periodical checks to confirm proper operation.



Safety Instructions

Caution

1. The product is provided for use in manufacturing industries.

The product herein described is basically provided for peaceful use in manufacturing industries.

If considering using the product in other industries, consult SMC beforehand and exchange specifications or a contract if necessary.

If anything is unclear, contact your nearest sales branch.

Limited warranty and Disclaimer/Compliance Requirements

The product used is subject to the following “Limited warranty and Disclaimer” and “Compliance Requirements”.

Read and accept them before using the product.

Limited warranty and Disclaimer

1. The warranty period of the product is 1 year in service or 1.5 years after the product is delivered, whichever is first.*2)

Also, the product may have specified durability, running distance or replacement parts. Please consult your nearest sales branch.

2. For any failure or damage reported within the warranty period which is clearly our responsibility, a replacement product or necessary parts will be provided.

This limited warranty applies only to our product independently, and not to any other damage incurred due to the failure of the product.

3. Prior to using SMC products, please read and understand the warranty terms and disclaimers noted in the specified catalog for the particular products.

***2) Vacuum pads are excluded from this 1 year warranty.**

A vacuum pad is a consumable part, so it is warranted for a year after it is delivered.

Also, even within the warranty period, the wear of a product due to the use of the vacuum pad or failure due to the deterioration of rubber material are not covered by the limited warranty.

Compliance Requirements

1. The use of SMC products with production equipment for the manufacture of weapons of mass destruction (WMD) or any other weapon is strictly prohibited.

2. The exports of SMC products or technology from one country to another are governed by the relevant security laws and regulations of the countries involved in the transaction. Prior to the shipment of a SMC product to another country, assure that all local rules governing that export are known and followed.

1. Product Specifications

1-1. Specifications

	ø16	ø25	ø40
Fluid	Air		
Proof pressure	1.2 MPa		
Max. operating pressure	0.8 MPa		
Min. operating pressure	0.1MPa		
Ambient and fluid temperature	+5 to +60 °C (No freezing)		
Lubrication	Not required (non-lube)		
Stroke length tolerance	1000 or less $+1.8_0$ mm	2700 or less $+1.8_0$ mm	
	1001 to max stroke $+2.8_0$ mm	2701 to max stroke $+2.8_0$ mm	
Cushion	Air cushion, Shock absorber		
Piston speed	100 to 1500 mm/s		

Warning

1. Confirm the specifications.

The product is designed for use only in industrial compressed air systems. Do not operate at pressures or temperatures etc., beyond the range of specifications, as this can cause damage or malfunction. (Refer to the specifications.)

Contact SMC in advance for non-industrial uses, or if using with a fluid other than compressed air. SMC does not guarantee against any damage if the product is used outside the specification range.

2. Do not operate the product with the guide load factor that is more than the allowable value.

Mechanically jointed rodless cylinder has a guiding function with the cylinder. It is possible to mount a load directly to the cylinder. Use caution not to allow the guide load factor to exceed the allowable value.

Operation with the load out of the allowable range may cause damage to the cylinder or an operation failure at an earlier stage.

Refer to the catalogue for the calculation method for the allowable guide load.

3. Confirm the applicable range of the specifications.

The product specifications are applicable to all the standard strokes including an intermediate stroke and long stroke.

For custom-made products/special products other than shown above may not have specifications that are different from the specifications described in this manual. Please contact SMC for the specifications of custom-made or special products.

⚠ Caution

1. Air leakage due to removal of the seal belt

Mechanically jointed rodless cylinders may have a temporary external air leakage in some operating conditions due to the product construction when negative pressure is generated inside the cylinder with external force, inertial force, or etc. When this happens, refer to "How to put back the seal belt when it comes off" shown below and carefully return the seal belt to the position not to damage the seal belt. Damage to the seal belt may cause permanent air leakage.

How to put back the seal belt when it comes off

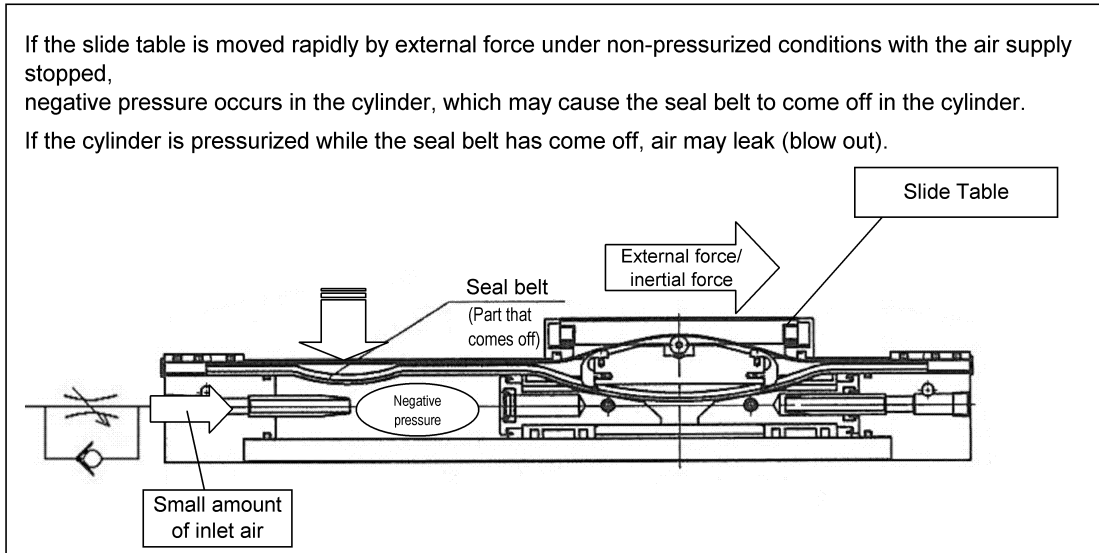

	Procedure	Cautions
①	Shut off the air supply and keep it unpressurized	Do not leave any residual pressure.
②	Remove the piping connected to the cylinder, and release it to atmosphere.	Remove anything that will act as a restrictor, such as a speed controller, wherever possible.
③	Make sure the cylinder can perform a total stroke	If a stroke adjustment unit is mounted, remove it or adjust the stroke to perform a total stroke. If an external stopper is mounted, remove it or take measures so it will not stop the cylinder from performing the total stroke.
④	Move the slide table slowly by hand to make a full return stroke.	If the slide table gets stuck (does not move smoothly) while it is being moved, do not force it. Pull it back slightly and then move it forward again. (If the cylinder is mounted vertically, remove work pieces and move the slide table by hand, the same as it would in operation)
⑤	Connect the piping to the cylinder and supply air gradually.	If there are no remarkable amount of air leaks, this completes the procedure.

2. Operation and Mounting

2-1. Air supply

The compressed air supplied to the cylinder should be filtered by SMC AF series air filter and regulated to the specified set pressure by SMC AR series regulator.

⚠ Warning

1. Use clean air.

Do not use compressed air that contains chemicals, synthetic oils including organic solvents, salts or corrosive gases etc., as this can cause damage or malfunction.

Caution

1. Install an air filter.

Install an air filter upstream near the valve. Select an air filter with a filtration size of 5µm or smaller.

2. Install an aftercooler, air dryer or drain catch before the filter.

Compressed air that contains excessive foreign material may cause malfunction of valves and other pneumatic equipment.

3. Discharge condensates regularly.

If condensate in the drain bowl is not emptied on a regular basis, the condensate will overflow and allow it to enter the compressed air lines. This will cause a malfunction of pneumatic equipment. If the drain bowl is difficult to check and remove, installation of a drain bowl with an auto drain option is recommended.

4. Use the product within the specified fluid and ambient temperature range.

When operating at temperatures below 5°C, moisture in the circuit may freeze and cause damage to the seals or a malfunction. Use within the specified operating temperature range.

5. Usage of ultra dry air as fluid

If ultra dry air is used as a fluid, the lubrication characteristics of the equipment will deteriorate and this can affect the reliability (life) of the product. Contact SMC before using with ultra dry air.

6. Lubrication of non-lubricating cylinder

The product has been lubricated during manufacturing, so it does not require lubrication in service.

If a lubricant is used in the system, use turbine oil Class 1 (with no additive) ISO VG32.

Once lubricant is used in the system, lubrication must be continued because the original lubricant applied during manufacturing will be washed away.

For detailed information regarding the quality of the compressed air described above, refer to SMC's "Air Cleaning Systems".

2-2. Operating Environment

Warning

1. Do not use in environments where there is a danger of corrosion.

2. Do not use in direct sunlight.

3. Do not operate in a location subject to vibration or impact.

4. When using auto switches, do not operate in an environment with strong magnetic fields.

5. Grease base oil can decrease depending on external environment and operating conditions. This may reduce the lubrication performance and shorten the life of the equipment.

6. Avoid using the product in an environment that exposed to foreign matter.

If the cylinder is used in an environment where there is possible contact with cutting chips, dust (paper, yarn debris, etc.), spatter or any liquids (cutting oil, light oil, moisture, etc.), debris may enter the cylinder and cause operation failure.

When operating in such an environment is unavoidable, mount a cover to the product or mount the product on the Ceil. Note that some liquid coolant may give adverse influence to the sealing parts.

7. Avoid storing the product in high temperature and/or humid conditions.

Rust may be generated or the sealing parts may be deteriorated in such an environment.

2-3. Design

The compatibility of the product is the responsibility of the person who designs the equipment or decides its specifications.

Warning

1. There is a possibility of dangerous sudden action by cylinders if force is changed due to twisting of sliding parts of machinery.

In such cases, human injury may occur; e.g., by catching hands or feet in the machinery, or damage to the machinery itself may occur. Therefore, the machine should be designed to operate smoothly and avoid such dangers.

2. A deceleration circuit or shock absorber etc. may be required.

When a driven object moves at a high speed or the load is heavy, it may be unfeasible for only the cylinder's air cushion or shock absorber to absorb the shock. Therefore, provide a speed reduction circuit to reduce the cylinder's speed or install an external shock absorber to dampen the shock. If these countermeasures are taken, confirm the rigidity of the equipment carefully.

3. A protective cover is recommended to minimize the risk of personal injury.

If the driven object or moving parts of the product will pose a hazard to humans, a construction that prevents direct contact with the exposed area must be provided.

For product with stroke adjustment unit, the clearance between the slide table (slider) and the stroke adjustment unit at the stroke end is small.

When the cylinder is operating at a high speed and high frequency, the surface temperature of the cylinder tube increases, and may cause injury to personnel.

4. Be certain that the mounting fasteners will not become loose..

When the product operates with high frequency or is installed where there is a lot of vibration, ensure that all parts remain secure.

5. Design the system so external forces over the maximum specifications will not be applied

The product can break, causing a risk of injury to personnel or damage to equipment.

6. The cylinder generates a large force. Install on a sufficiently rigid mounting base, taking this force into consideration.

There is a risk of injury to personnel or damage to equipment.

7. Consider an air pressure drop that caused by a power source related malfunction.

There is a danger of workpieces dropping if there is a decrease of thrust due to a drop in circuit pressure caused by a power source malfunction etc. Therefore, safety equipment should be installed to prevent damage to machinery and/or injury to personnel. Suspension equipment and lifting devices also require measures to prevent dropping.

8. Consider the possibility of power source related malfunctions.

For equipment that relies on power sources such as compressed air, electricity, or hydraulic pressure, adopt countermeasures to prevent the equipment from causing a hazard to humans or damage to the equipment in the event of malfunction.

9. Consider the behavior of an emergency stop.

A safety system should be devised so that if personnel engage the emergency stop, or if a safety device is tripped during a system malfunction (such as a power source malfunction), the movement of the cylinder will not cause a hazard to personnel or damage the equipment.

10. Consider the action when operation is restarted after an emergency stop or abnormal stop.

Design the machinery so that personal injury or damage to equipment will not occur upon restart of operation. Install manually controlled equipment for safety when the actuator has to be reset to the starting position.

 **Caution**

1. Operate the product within a range such that the piston will not collide and be damaged at the stroke end.

If the piston with inertia force is stopped by colliding with the cover at the stroke end, operate the cylinder within a range that will not cause damage. Refer to "Cushion Capacity" shown on P. 1364 in SMC's catalogue "Best Pneumatics 2, version 5 " for the range that will not cause damage.

2. Mount an intermediate support to a long stroke cylinder.

For a long stroke cylinder, mount an intermediate support to prevent vibration or external force from being applied to the product or to prevent deflection of the body due to the product's own weight.

3. When using an external guide together with the cylinder, hold the load only with the external guide, and only use the cylinder as a driving source.

The longer the stroke, the greater the amount of variation in the center axis..Therefore, a method of connection which can absorb the displacement (i.e. floating mechanism) should be considered. A cylinder that is suitable to be used as a driving source (basic type series) is also available. Please refer to the catalogue for details.

4. Avoid using cylinders for synchronized operations.

Even if multiple cylinders are initially set to the same speed, their speeds may vary due to changes in operating conditions. In such a case, an excessive moment will be applied to the slide tables and it may cause operation failure. Do not design a circuit using more than one cylinder in a synchronized operation to transfer one load.

5. Grease has been applied on the cylinder surface.

Do not wipe it off. Removing the grease may cause malfunction due to lack of lubrication.

6. The pre-applied grease may result in base oil seeping out.

The base oil of the grease in the cylinder may seep out of the tube, cover, slider or guide sliding part depending on the operating conditions (ambient temperature 40 °C or more, pressurized condition, low frequency operation).

7. Do not use the cylinder without the guide for driving a load

The MY2 series cylinder for driving can be detached from the guide. However, it is constructed to be used for driving the product body, it may cause failure if it is used solely with a load applied.

2-4. Mounting and Installation

2-4-1. Mounting Surface

It is recommended to mount the cylinder on a surface with a high flatness (e.g. a machined surface). If the mounting surface flatness is questionable, use shims to adjust the flatness to make it possible for the slide table to operate with the minimum operating pressure (0.1 MPa) for the entire stroke.

Mounting surface of the slide table is machined with high accuracy. Flatness of the mounting surface of the mating part must be 0.03 at maximum. When the flatness cannot be obtained, use shims for adjustment of the mounting surface of the cylinder as shown above.

2-4-2. Mounting

- Two mounting methods are available for this cylinder:

Choose the mounting method according to the mounting surface and the mounting place conditions.

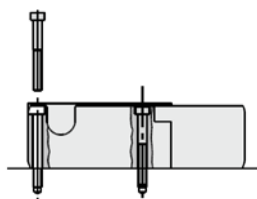

Fig. 1: Holding the product from the top with hexagon socket head cap screws
(End plates on the both ends)

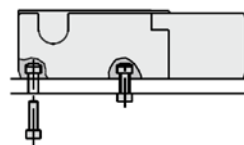

Fig. 2: Holding the product from the bottom
(T slot on the bottom)

- When holding the product using the end plates at the both ends, secure mounting surfaces of 5mm or more on the bottom side at the both ends of the cylinder. (See Fig. 3)

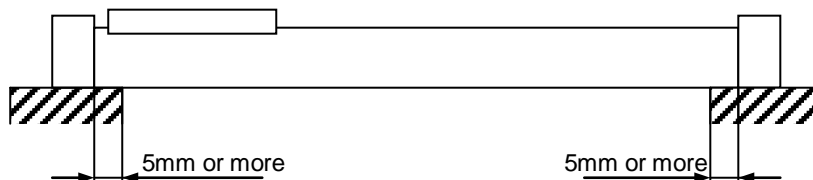

Fig. 3

- Do not mount the product with the slide table fixed as shown in Fig. 4. Excessive load will be applied to the bearing, and it may cause operation failure.

- Contact SMC for cantilever mounting as shown in Fig. 5. It may cause operation failure with the body deflected.

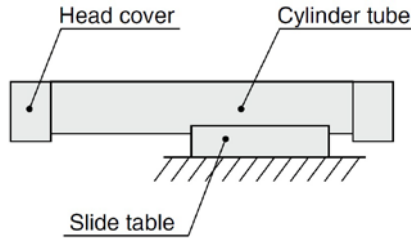

Fig. 4: Product mounting with the slide table fixed
(Prohibited)

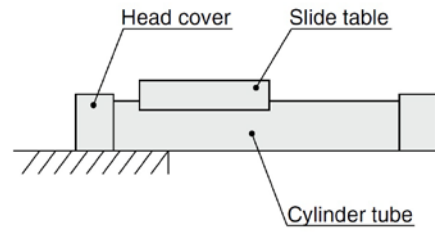

Fig. 5: Cantilever mounting
(Consult SMC.)

- The cylinder tube of MY2C series may deflect due to its own weight, load, or etc. When the cylinder tube is deflected, hold the cylinder at the intermediate position using the side support. Support spacing (L) shown in Fig. 6 must be the values shown in Fig. 7 or less.

Note) Using the side support for mounting a cylinder that has mounting surfaces that are not flat enough may cause failure. Adjust the mounting surface level when using the side support. (Recommended flatness: 0.1 or less)

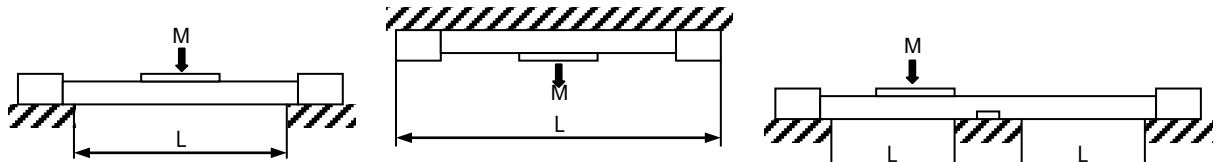

Fig. 6

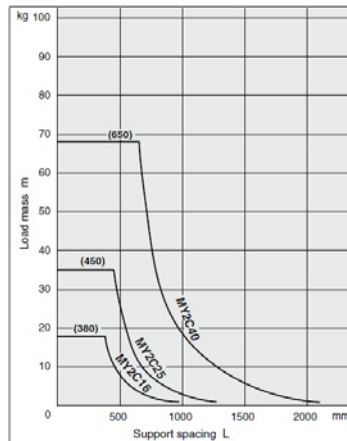

Fig. 7

- When using the product that has a stroke that exceeds the stroke fine adjustment range, use an intermediate fixing spacer. Refer to the table below for the stroke fine adjustment range and the stroke adjustment range when using the intermediate fixing spacer.

		0	-10	-20	-30	-40	-50
MY2*16	L unit	0 to 10	10 to 20	20 to 30			
	H unit	Without spacer	Short spacer	Long spacer			
MY2*25	L unit	0 to 12	12 to 24	24 to 36			
	H unit	Without spacer	Short spacer	Long spacer			
MY2*40	L unit	0 to 16	16 to 32	32 to 48			
	H unit	Without spacer	Short spacer	Long spacer			

Table 1: Stroke adjustment range (Without spacer, with short spacer, with long spacer)

Warning

1. Secure all the mounting screws firmly to mount the slide table.

If not, the slide table and/or the mounting screws may be damaged, and the workpiece may drop.

Caution

1. Do not apply a strong impact or excessive moment to the slide table.

The slide table is supported by a precision guide. Do not apply a strong impact or excessive moment when mounting a workpiece.

2. When connecting a load with an external guide mechanism, be sure align carefully.

3. Do not hit or grip the cylinder tube with objects.

Scratches or dents in the external circumference of the cylinder tube may damage the bearing and/or the scraper, and it may cause operation failure.

4. Use caution not to allow foreign matter such as cutting particles to enter the cylinder from the air supply port.

Foreign matter such as cutting particles or dust entering the product during the product mounting may cause operation failure.

5. Do not change the setting of the guide adjusting part without careful consideration.

The guide has been adjusted as default. Readjustment will not be required in normal operating conditions. If play occurs, check the operating conditions and contact SMC.

6. Do not fix the stroke adjustment unit at the intermediate position.

The stroke adjustment unit may be displaced depending on the volume of the collision energy.

7. Do not use the product until you have verified that the equipment can operate properly.

After mounting or repair, connect the air and power supplies to the product and perform appropriate functional and leakage inspections to check it is mounted properly.

2-5. Piping

Ports on the head cover for piping connection can be selected as preferred.

Refer to the port variation diagram (see Fig. 8) to find the most suitable ports for piping connection.

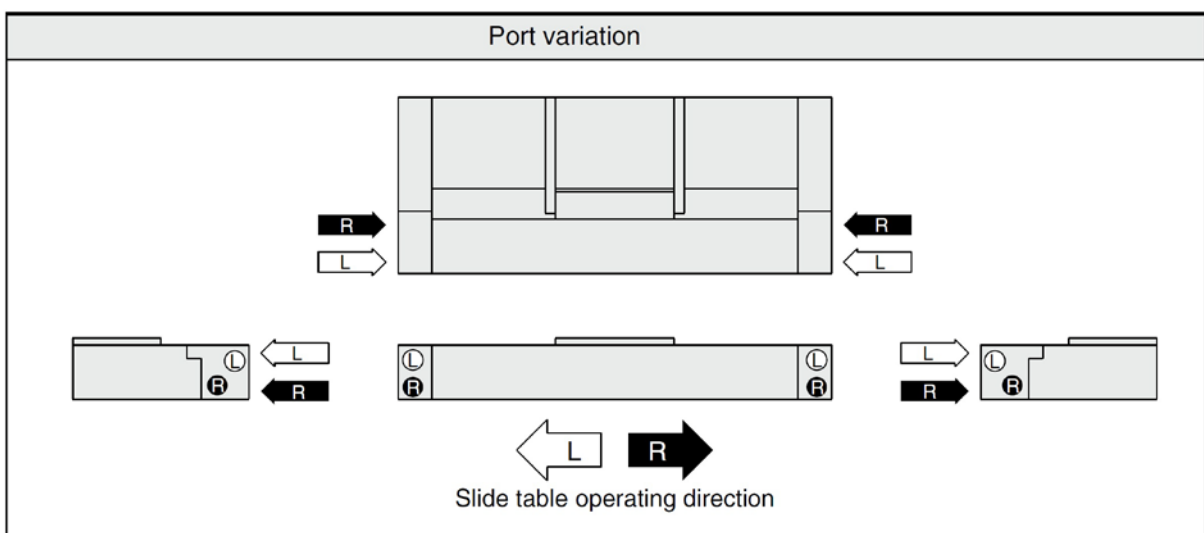

Fig. 8

Caution

1. Before piping

Before piping is connected, the pipe should be thoroughly blown out with air (flushing) or washed to remove chips, cutting oil and other debris from the inside.

2. Sealant tape

When screwing piping or fittings into ports, ensure that chips from the pipe threads or sealing material do not enter the piping.

Also, if pipe tape is used, leave 1.5 to 2 thread ridges exposed at the end of the threads.

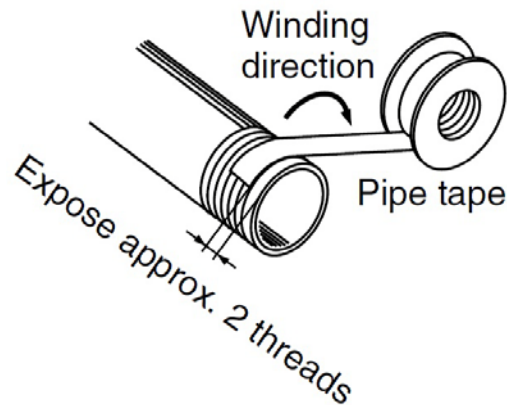

Fig. 9: Wrapping of pipe tape

2-6. Speed Control

When the piston speed is adjusted, install SMC AS series speed controller near the air supply port to adjust to the specified speed. There are two methods of speed adjustment, one is to restrict air supplied to the product, and the other is to restrict air exhausted from the product. Normally, the latter method should be adopted.

Caution

1. Use a speed controller to adjust the cylinder drive speed, gradually increasing from a low speed to the desired speed setting.

2. Performance using at constant speed

Mechanically jointed rodless cylinder has a larger fluctuation in speed compared to the rod air cylinder due to its construction.

Consult SMC for the product usage for an application which requires a constant speed operation.

2-7. Shock Absorbing Mechanism

2-7-1. Air Cushion

The cushion needle is adjusted as default when the product is shipped..The cushion needle on the head cover should be readjusted when the product is put into service, based upon factors such as the size of the load and the operating speed. When the cushion needle is turned clockwise, air is restricted more and the cushion's effectiveness is increased.

2-7-2. Stroke Adjustment Unit

- Fixation of the unit body

The unit body can be fixed by evenly tightening the stroke adjustment unit retaining screws.

- Stroke adjustment of the shock absorber (MY2C, MY2H)

Adjust the stroke by rotating the shock absorber after loosening the lock nut for shock absorber (for H unit of MY2H16, loosen the shock absorber retaining screws). After adjusting the stroke, tighten the lock nut (the retaining screws) to fix the shock absorber.

- Stroke adjustment of the shock absorber (MY2HT)

Adjust the stroke by rotating the shock absorber after loosening the two stroke adjustment unit retaining screws on the cylinder side. After adjusting the stroke, tighten the retaining screws evenly to fix the shock absorber.

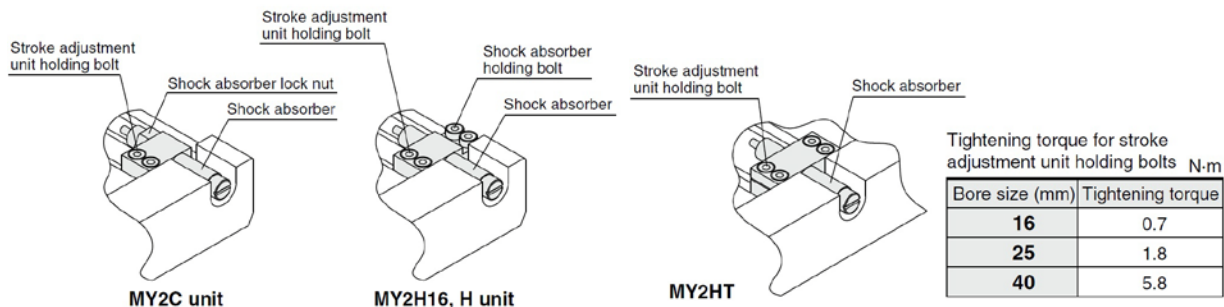

Fig. 10: Stroke adjustment unit

⚠ Warning

1. Do not operate the product when the cushion capacity that exceeds the allowable value.

Operation while exceeding the allowable cushion capacity may damage the cylinder and may cause injury or damage to equipment. If operation requires a larger cushion capacity, install an external absorber to prevent impact to the cylinder body. Confirm the rigidity of the equipment after the measure shown above is taken.

2. Do not open the cushion needle too much.

The cushion needle may come out when it is rotated too much in the counterclockwise direction. Keep the top of the cushion needle below the head cover level. Note that it is very dangerous if the cushion needle comes out while air is being supplied to the product.

3. Do not operate the cushion valve in the fully closed state.

It may damage the seal.

2-8. Directional Control

To change the operating direction of the cylinder, mount an applicable solenoid valve selected from SMC's range of solenoid valves.

⚠ Warning

1. Design a circuit to prevent sudden action of a driven object.

When the product is actuated by an exhaust center type directional control valve or when one side of the piston is pressurized with air exhaust, such as when the product is started after the exhaust of the residual pressure from the circuit, driven objects may act suddenly at high speed. In such cases, injury may occur, such as hands or feet getting caught in the machinery, or damage to the machinery itself may occur. Design the machinery using equipment to prevent sudden action.

2. Intermediate stop

Due to the compressibility of air, it is difficult for this product to make a piston stop at the required intermediate position accurately and precisely.

Mechanically jointed rodless cylinder has a special seal in the construction, and this causes a minimal amount of external air leakage. A three position closed center type directional control valve may not hold the slide table in the intermediate position for an extended period of time, and the speed may not be controlled when restarting the operation.

Rodless cylinder has the same pressure receiving areas in all the pressure chambers. -The table will also stop with a circuit that has air supply from both sides. Use a circuit that controls pressure supply to both sides that uses a three position pressure center type directional control valve for intermediate stop. For holding the intermediate stop for an extended period of time, use a device to prevent it from moving for designing a circuit. Consult SMC for details.

2-9. Mounting of Auto Switch

To mount the auto switch, insert it into the switch mounting groove. Set the switch in the appropriate position and secure it with the switch mounting screws provided with the product using a precision flat head screwdriver.

Refer to the catalogue (P. 1384 in Best Pneumatics 2, Version 5) for the correct mounting position.

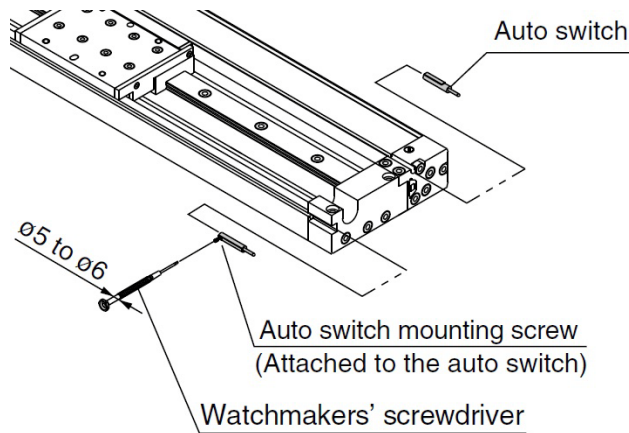

Fig. 11

Note) For the tightening of the mounting screws, use a precision screwdriver with a handle diameter of approximately 5 to 6 mm. Use the tightening torque of approximately 0.05 to 0.1 Nm. As a guide, turn 90° from the position where the mounting screw starts to become tight.

Caution

1. For the handling of the auto switch, refer to the Operation Manual of the auto switch.
2. Do not let objects drop onto the product or apply with an excessive impact to the product when handling.
3. Avoid wiring that applies repeated bending stress and/or tensile force on the lead wire.
4. It is possible to mount an auto switch in the intermediate position, but the cylinder speed for the switch detection needs to be adjusted to 300 mm/sec. or less in accordance with the response time of the load relay, etc.
5. When mounting an auto switch on the driving cylinder side (on top of the cylinder), avoid interference of the auto switch with the workpiece.

When mounting a vertical cable entry type auto switch on the driving cylinder side (on top of the cylinder), lead wire may interfere with the workpiece depending on how the workpiece is mounted and the shape of the workpiece. Allow extra space to avoid interference of the workpiece with the cable on the workpiece side.

6. When operating multiple cylinders with the auto switch in parallel, separate the cylinders, maintaining a minimum separation distance of at least 40mm. (See Fig. 12)

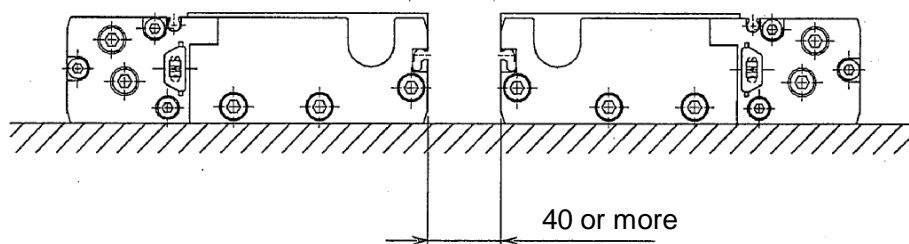

Fig. 12

7. If attaching the workpiece magnetically, the auto switch may stop working due to a loss of magnetic force in the cylinder depending on the mounting position. Allow a clearance of 5 mm or more between the auto switch and workpiece.

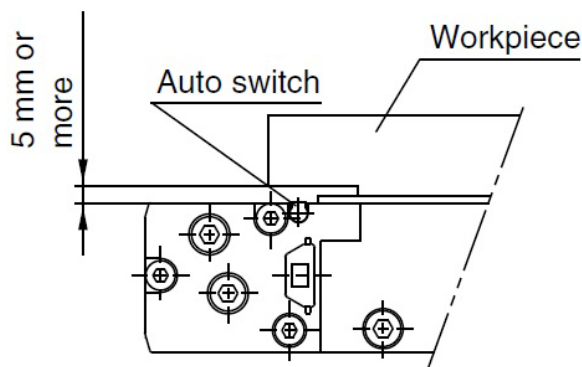

Fig. 13: Auto switch mounting on the cylinder side

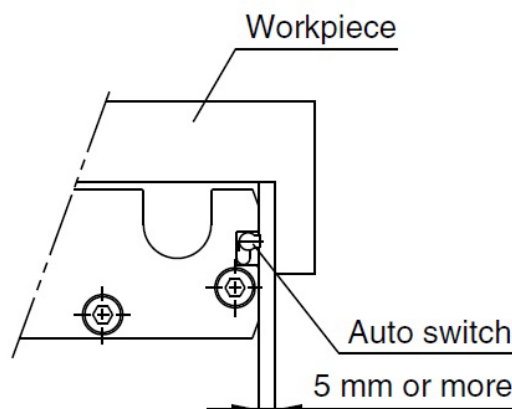

Fig. 14: Auto switch mounting on the guide side

3. Maintenance

3-1. Inspections

3-1-1. Daily Check

- 1) Smoothness of the operation
- 2) Changes in piston speed and cycle time
- 3) Smooth movement of the slide table for the entire stroke

3-1-2. Regular Check

Check for the following items:

- 1) Any loose mounting bolts: cylinder mounting, work piece mounting bolts, etc.
- 2) Smooth operation
- 3) Changes in the piston speed and cycle time
- 4) Smooth movement of the slide table for the entire stroke
- 5) Air leaks
- 6) Any scratches or damages to the cylinder
- 7) No drain in the air filter and/or piping
- 8) Increase in the play of the slider (slide table)

When check of the items shown above finds any problems with the cylinder, take the necessary countermeasures referring to the section "4. Troubleshooting".

3-2. Maintenance

Monthly application of grease to the slide bearing (guide) and the dust seal band may lengthen the life.

Use the grease recommended by SMC.

Grease pack part number: GR-S-010 (10g), GR-S-020 (20g)

3-3. Replacement Parts

Refer to the catalog the parts that can be replaced.

⚠ Warning

1) Maintenance should be performed according to the items above.

Improper handling can cause damage or malfunction of equipment and machinery.

2) Removal of equipment, and supply/exhaust of compressed air

When the equipment is serviced, first confirm that measures are in place to prevent any dropping of driven objects and run-away of equipment, etc. Then turn off the supply pressure and power, exhaust all compressed air from the system using its residual pressure release function.

Before restarting the equipment, confirm that measures are taken to prevent sudden action.

4. Troubleshooting

Failure	Major causes	Countermeasures
Operation is not smooth. The speed or cycle time has changed.	Misalignment of the workpiece and cylinder axis, or the guide axis of the workpiece and cylinder axis, or application of external force to the cylinder due to usage of a cable bearer, etc.	Realign workpiece and cylinder Confirm that the cylinder operates smoothly without air supplied to the cylinder. Consider using a Floating Bracket (available from SMC) or connecting pipes using a floating mechanism.
No operation	Operation at low speed	Keep the specified range.
	Non conforming air system configuration	Use piping tube, fitting, directional control valve, speed controller etc. of adequate size.
	Lack of grease on the sliding surface	Add grease. (On the top surface and sliding surface of the cylinder tube, approximately 5 g/500 stroke) - Grease is lost due to infiltration of moisture such as drain. - Lubrication is stopped after it is lubricated once. - It is operated in the environment in which it gets liquid splash.
	Insufficient air pressure	Supply adequate pressure. Take necessary countermeasures if any of the following applies. - Pressure source has decreased (including insufficient flow). - Incorrect setting of the regulator. - Clogging, disconnection, bending, or etc. of the piping.
	Insufficient cylinder output	Increase the operating pressure or the cylinder bore size. It should be selected with the sufficient load factor taking resistance of the cylinder and peripherals into consideration.
	Failure of the equipment other than the cylinder	Investigate concerned components one by one. Take necessary countermeasures if any of the following applies. - Failure of the directional control valve. - The speed controller is not adjusted properly. - The speed controller has failed. - Clogging, disconnection, or bending of the piping. - Clogging of the filter, etc.
Abnormal stroke	Lodging of foreign matter.	Check if there is any foreign substance caught between the slider and the external stopper, etc.
	Foreign substances entered inside the cylinder.	Check if there is any foreign substance such as drain inside the cylinder.
Air blowing-by	Removal of the seal belt	Refer to "How to put back the seal belt when it comes off" on page 5 in the section "1. Product Specifications", and return the seal belt into the specified position.
	Wear of the seals	Replace the seals with the new ones. Take necessary countermeasures if any of the following applies. - Application of a load that is larger than the allowable load. - Operation in an ambient temperature that is out of the operating temperature range. - Shortage of grease. - Foreign matter entering the product.

Failure	Major causes	Countermeasures
Damage to the parts.	Operation at high speed	Adjust the speed by the speed controller and keep the specified range.
	Excessive impact at the stroke end	Use a shock absorber which absorbs kinetic energy generated by the slider.
	Overload or excessive moment	Select the cylinder model that keeps the guide load factor of the cylinder within the allowable range.
	Action of external force	Structural interference, unbalanced load or over-load may cause damage and/or deformation of the cylinder. Insure these conditions do not exist.
The play of the slider increased.	Wear-out of the slide bearing	The table can be readjusted if the wear of the slide bearing is not significant. Contact SMC for readjustment of the slide table. If the wear is significant, it will be necessary to replace the bearing.
	Wear or damage to the cam follower guide	Refer to the item "Damage to the parts" shown above, and take the countermeasures provided.
	Wear-out or damage of the linear guide	Refer to the item "Damage to the parts" shown above, and take the countermeasures provided.
	Damage of the parts around the bearing (guide)	Refer to the item "Damage to the parts" shown above, and take the countermeasures provided.

Caution

- 1. Contact SMC if cylinder needs to be disassembled. Air leaks may occur if the seals are damaged during disassembly. Disassembling or modifying the internal wiring will void the product's warranty. If you need it warranted, ask SMC for repair.**

Revision history

SMC Corporation

4-14-1, Sotokanda, Chiyoda-ku, Tokyo 101-0021 JAPAN

Tel: + 81 3 5207 8249 Fax: +81 3 5298 5362

URL <http://www.smcworld.com>

Note: Specifications are subject to change without prior notice and any obligation on the part of the manufacturer.
© 2011 SMC Corporation All Rights Reserved