



Operation Manual

PRODUCT NAME

Card Motor Controller

Model / Series / Product Number

LATC4 Series

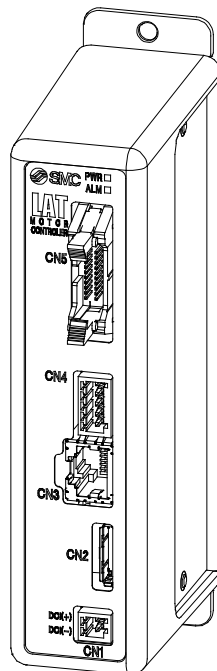

SMC Corporation



Contents

1. Safety Instructions	4
2 Product overview	6
2.1 Features.....	6
2.2. How to Order.....	8
2.3. Structure of the product	9
2.4 Procedures (How to start the Card Motor)	10
(1) Checking the contents of the package.....	10
(2) Mounting the Controller.....	10
(3) Wiring and Connection	10
(4) Power supply ON Alarm check.....	11
(5) Setup of the setting data (operation pattern).....	11
(6) Test operation.....	11
3. Specifications	12
3.1 Basic specifications.....	12
3.2 Parts description	13
3.3 External dimensions.....	14
(1) Screw mounting (LATC4-**).....	14
(2) DIN rail mounting (LATC4-**D).....	14
3.4 Mounting.....	15
(1) Mounting.....	15
(2) Grounding.....	15
(3) Location for mounting.....	16
4. External connection	17
4.1 CN1: Power supply connector	17
4.2 CN2: Motor connector	17
4.3 CN3: Parallel I/O connector.....	17
4.4 CN4: Counter connectors (Option).....	18
4.5 CN5: Parallel I/O connector.....	18
5. CN1: Power supply plug	19
5.1 Power supply plug specifications.....	19
5.2 Electrical wiring specifications.....	19
5.3 Power supply plug wiring.....	20
6. CN4: Counter plug	21

6.1 Counter plug.....	21
6.2 Counter plug wiring.....	21
7. CN5: Parallel I/O Connector.....	22
7.1 Parallel input / output.....	22
7.2 Parallel I/O circuit (NPN, PNP).....	22
(1) Parallel I/O input circuit (NPN, PNP common).....	22
(2) Parallel I/O output circuit.....	23
7.3 Parallel I/O signals.....	24
7.4. Parallel I/O connector wiring (Example).....	28
8. Settings and Data Entry.....	29
8.1 Basic parameter setup.....	29
8.2 Step Data Setup setting method and movement profiles.....	30
(1)Cycle time entry method.....	30
(2) Speed entry method.....	31
8.3 Step Data setup.....	33
8.4 Monitor/Test.....	35
9. Operations.....	37
9.1 Return to origin position.....	37
9.2 Positioning operation.....	39
9.3. Pushing operation.....	39
(1) Successful pushing operation.....	39
(2) When the workpiece moves.....	40
9.4 Jogging and Inching.....	40
9.5 Response time for the controller input signals.....	41
9.6 Methods of interrupting operation.....	41
10 Operation examples and procedures.....	43
10.1 Return to Origin example and procedure.....	43
10.2 Positioning operation example and procedure.....	44
10.3. Pushing operation example and procedure.....	45
11. Operation instruction.....	46
11.1 Overview of the operation instructions.....	46
11.2 Parallel I/O operation procedures.....	46
(1) Power on and Return to Origin position.....	46
(2) Positioning operation.....	47
(3) Pushing operation.....	47
(4) Alarm reset.....	48

12. Card Motor Controller Setting Software	49
12.1 Setup of the Controller Setting Software.....	49
12.2 Basic Parameter Setup window.....	51
12.3. Step Data Setup window	53
12.4 Monitor/Test window	58
12.5 I/O Setup window.....	62
12.6 Closing the software	64
13. Option	65
13.1. I/O cable.....	65
13.2 Controller setting kit.....	65
13.3. Multi-counter CEU5.....	66
14. Alarm detection	67
14.1 AlarmLED display.....	67
14.2 Alarms and countermeasures	68
15. Controller and Peripheral Devices / Specific Product Precautions	69
15.1 Design and selection.....	69
15.2 Handling Precautions.....	69
15.3 Installation	71
15.4 Power supply.....	71
15.5 Grounding.....	71
15.6 Wiring.....	72
15.7 Operating environment.....	72
15.8 Maintenance	73
16. Troubleshooting	74
16.1 Operation troubles.....	74
16.2 Position / Speed troubles	77



LATC4 Series Controller

1. Safety Instructions

These safety instructions are intended to prevent hazardous situations and/or equipment damage. These instructions are categorized into three groups, "Caution", "Warning" and "Danger" depending on the level of hazard and damage, and the degree of emergency. They are all important notes for safety and must be followed in addition to International Standards (ISO/ IEC), Japan Industrial Standards (JIS)*1) and other safety regulations*2).

*1) ISO 4414: Pneumatic fluid power -- General rules relating to systems

ISO 4413: Hydraulic fluid power -- General rules relating to systems

IEC 60204-1: Safety of machinery -- Electrical equipment of machines (Part 1: General requirements)

ISO 10218-1992: Manipulating industrial robots -- Safety

JIS B 8370: Pneumatic fluid power - General rules relating to systems

JIS B 8361: Hydraulic fluid power - General rules relating to systems

JIS B 9960-1: Safety of machinery - Electrical equipment of machines (Part 1: General requirements)

JIS B 8433-1993: Manipulating industrial robots - Safety, etc/

*2) Labor Safety and Sanitation Law, etc.



Caution

Caution indicates a hazard with a low level of risk which, if not avoided, could result in minor or moderate injury.



Warning

Warning indicates a hazard with a medium level of risk which, if not avoided, could result in death or serious injury.



Danger

Danger indicates a hazard with a high level of risk which, if not avoided, will result in death or serious injury.

Warning

(1) The compatibility of the product is the responsibility of the person who designs the equipment or decides its specifications.

Since the product specified here is used under various operating conditions, its compatibility with specific equipment must be decided by the person who designs the equipment or decides its specifications based on necessary analysis and test results.

The expected performance and safety assurance of the equipment will be the responsibility of the person who has determined its compatibility with the product.

This person should also continuously review all specifications of the product referring to its latest catalog information, with a view to giving due consideration to any possibility of equipment failure when configuring the equipment.

(2) Only personnel with appropriate training should operate machinery and equipment.

The product specified here may become unsafe if handled incorrectly.

The assembly, operation and maintenance of machines or equipment must be performed by an operator who is appropriately trained and experienced.

(3) Do not service or attempt to remove product and machinery/equipment until safety is confirmed.

1. The inspection and maintenance of machinery/equipment should only be performed after measures to prevent dropping of driven objects or run-away of machinery/equipment have been confirmed.

2. When the product is to be removed, confirm that the safety measures as mentioned above are implemented and the power from any appropriate source is cut, and read and understand the specific product precautions of all relevant products carefully.

3. Before machinery/equipment is restarted, take measures to prevent unexpected operation and malfunction.

(4) Contact SMC beforehand and take special consideration of safety measures if the product is to be used in any of the following conditions.

1. Conditions and environments outside of the given specifications, or use outdoors or in a location exposed to direct sunlight.

2. Installation on equipment in conjunction with atomic energy, railways, air navigation, space, shipping, vehicles, military, medical treatment, combustion and recreation, or equipment in contact with food and beverages, emergency stop circuits, clutch and brake circuits in press applications, safety equipment or other applications unsuitable for the standard specifications described in the product catalog.

3. An application which could have negative effects on people, property, or animals requiring special safety analysis.

4. Use in an interlock circuit, which requires the provision of double interlock for possible failure by using a mechanical protective function, and periodical checks to confirm proper operation. Check the product regularly in order to confirm normal operation.



LATC4 Series Controller

1. Safety Instructions

Caution

The product is provided for use in manufacturing industries.

The product herein described is basically provided for peaceful use in manufacturing industries.

If considering using the product in other industries, consult SMC beforehand and exchange specifications or a contract if necessary.

If anything is unclear, contact your nearest sales branch.

Limited Warranty and Disclaimer/ Compliance Requirements

The product used is subject to the following “Limited warranty and Disclaimer” and “Compliance Requirements”.

Read and accept them before using the product.

[Limited Warranty and Disclaimer]

(1) The warranty period of the product is 1 year in service or within 1.5 years after the product is delivered, whichever comes first. *)

Also, the product may have specified durability, running distance or replacement parts. Please consult your nearest sales branch.

(2) For any failure or damage reported within the warranty period which is clearly our responsibility, a replacement product or necessary parts will be provided.

This limited warranty applies only to SMC product independently, and not to any other damage incurred due to the failure of the product.

(3) Prior to using SMC products, please read and understand the warranty terms and disclaimers noted in the specified catalog for the particular products.

***) Vacuum pads are excluded from this 1 year warranty.**

A vacuum pad is a consumable part, so it is warranted for a year after it is delivered.

Also, even within the warranty period, the wear of a product due to the use of the vacuum pad or failure due to the deterioration of rubber material are not covered by the limited warranty.

[Compliance Requirements]

When the product is exported, strictly follow the laws required by the Ministry of Economy, Trade and Industry (Foreign Exchange and Foreign Trade Control Law).

2 Product overview

2.1 Features

This controller is intended to be connected to the Card Motor to execute operations that can be preset by a PC and selected using input signals from an external device.

This controller can also output signals to indicate the status of the controller and the Card Motor, completed operation, alarms and position of the Card Motor to external devices.

[Features]

– Easy programming (Cycle time entry ^{Note)})

Positioning can be performed by setting [Target position], [Positioning time] and [Load mass].

The [Thrust Setting Value] setting enables a pushing operation with the set thrust force or less.

^{Note)} Cycle time entry

To operate the table based on the positioning time or frequently.

After the target position and positioning time have been set the speed, acceleration and deceleration are calculated automatically by the controller.

The Speed Entry Method can be used to transfer the table with a constant speed.

[Main functions]

– Positioning operation

The Card Motor table moves to and stops at the set target position.

The target position can be set in relation to the origin position at the retracted end (connector side) in "Absolute" movement mode, or in relation to the current position in "Relative" movement mode.

– Pushing operation

The table moves close to the target position and continues to move at a constant speed from there.

After the table has come into contact with the workpiece it pushes the workpiece with the set Thrust Setting Value or less.

– Return to origin position

The table moves in the specified direction and sets the origin position.

The origin position can be set to extended end position, retracted end position or sensor origin.^{note)}

^{Note)} The sensor method is effective only when the controller is connected to an LAT3F series Card Motor actuator.

– Operation status indication

In positioning operation the BUSY signal is ON when the Card Motor is moving.

The INP output turns ON when the Card Motor table is within the INP output range of the "Target Position".

In pushing operation the INF output turns ON when the pushing force exceeds the set "Threshold Force Value".

A master PLC can be used to monitor and control the Card Motor operation by monitoring these signals.

- Measurement of workpiece size and workpiece differentiation

The size of a workpiece can be measured by driving the Card Motor table in pushing operation against the workpiece, and the position where the table stopped can be displayed and output. Workpiece identification and judgment of good and bad workpieces is possible using parallel output signals, which correspond to table positions that can be preset.

It is possible to display and to output up to 31 preset table positions using the CEU5 Multi-counter (see section "13.3 Multi-Counter CEU5" on page 65).

- Alarm detection

An alarm signal is output if over current flows through the motor due to excessive heating of the motor, if the Card Motor has not been returned to the origin position and in case of an internal memory error.

The following functions can be performed by connecting the controller to a computer with the dedicated software installed.

- Parallel I/O connection and status check

The status of the parallel input signals can be checked and the parallel output signals can be manually switched.

- Step data settings

15 step data, which include the Card Motor operation details, can be set.

The Card Motor can be operated according to the step data settings by entering the step data number using the parallel input signals, the Card Motor operates according to the settings.

- Jogging and inching a set distance

The Card Motor can be jogged and inched a set distance to test operate it without using the step data.

- Display of the operation status

Current table position, speed, pushing force, parallel I/O status and alarm status are displayed on the computer.

- Test mode and Monitor mode

Either of the two operation modes can be selected: Test mode in which test operations of the Card Motor can be performed using the setting software, or Monitor mode in which the Card Motor can be operated by the parallel I/O signals while checking the operation status.

 **Caution**

When the device is set up or failure occurs refer to the operation manual of the actuator as well as to this operation manual.

*Keep this operation manual accessible so it can be referred to when necessary.

2.2. How to Order

How to order is shown below.

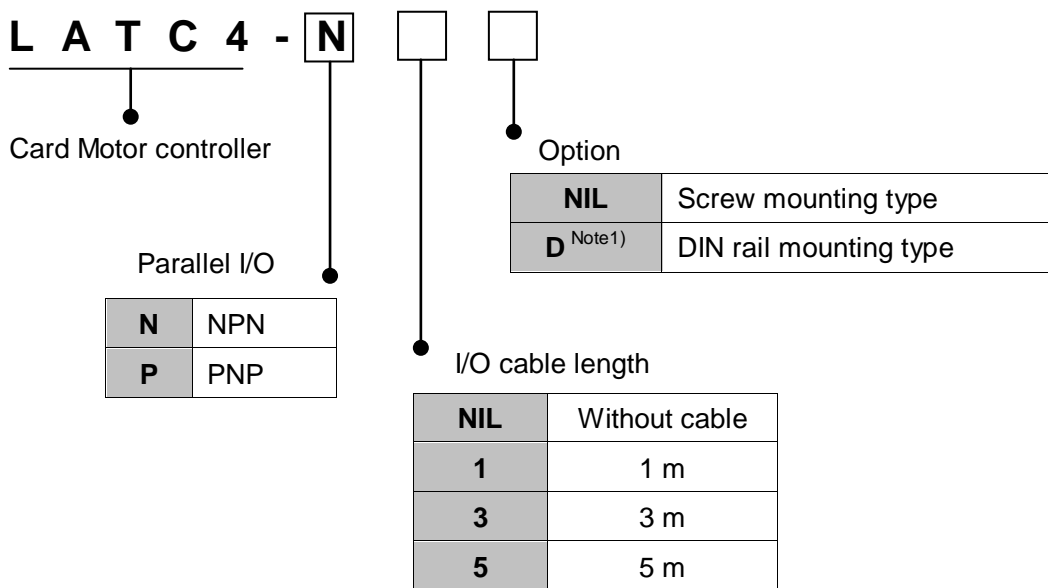

Note1) DIN rail is not included. Order it separately.

2.3. Structure of the product

An example of controller structure is shown below.

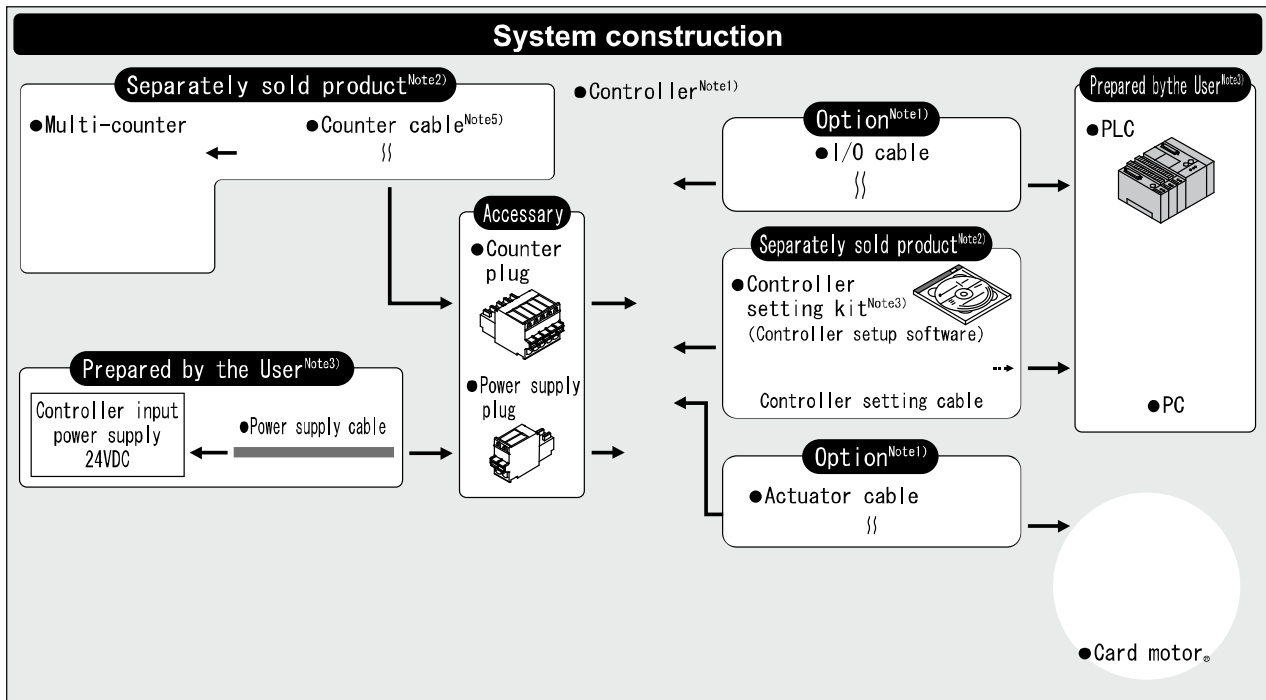

Note 1) It is possible to order the controller or option cable with how to order of the Card Motor.

The controller option part No. can be specified only for I/O cable.

Note 2) It is not possible to order the accessory with how to order of the Card Motor.

Refer to **13.Option (P.64)** and order it separately.

Note 3) PLC, power supply, power supply cables and PCs should be prepared by the user.

Note 4) the service condition (step data) etc. are set to the controller, and the test driving is done.

Note 5) the position of the table is displayed when length is measured, and the preset is output.

Caution

Refer to **4. External connection (P.17)** for wiring.

Refer to **15.Precautions for wiring and cables (P.68)** when handling the wiring and cables.

Please connect to the PC communication cable with the USB port cable via the conversion unit.

2.4 Procedures (How to start the Card Motor)

Install, wire, set and operate the controller referring to the procedure below when the product is used for the first time.

(1) Checking the contents of the package

Before using this controller, please connect cables and startup using the following procedures.

Product name	Quantity
Controller (LATC4-***)	1 pc.
Power supply plug	1 pc.
Counter plug	1 pc.

Controller

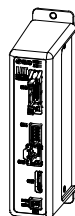

Power supply plug



Counter plug

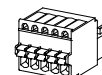

- Separately sold products -

Controller setting kit (Product model No.: LATC-W1)
[Controller setting software, communication cable, USB cable and conversion unit are included.]

Controller setting software



*If parts are missing or damaged, please contact our distributor.

(2) Mounting the Controller

Refer to [3.4 Mounting method \(P.15\)](#) to mount the controller.

(3) Wiring and Connection

Connect cables to the controller connector (CN1 to CN5).

Please refer to the [“4 External Wiring Diagram \(P.17\)”](#) for the wiring of the connectors.

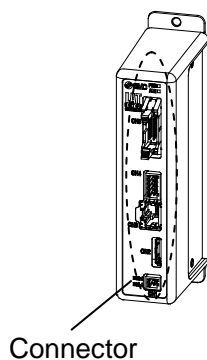

(4) Power supply ON Alarm check

Ensure the wires are properly connected and then supply 24 VDC power.

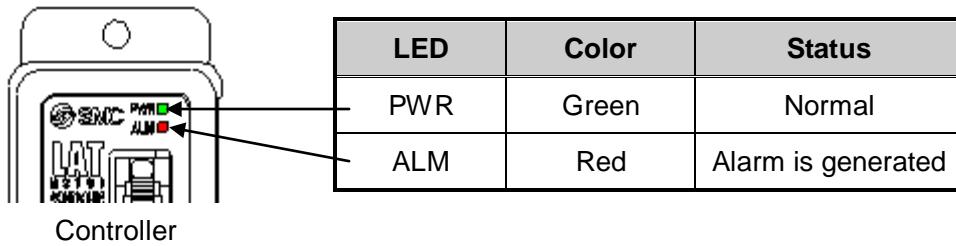

If the LED [PWR] on the front surface of the controller turns green, the controller is in the normal condition.

If the LED [ALM] on the front surface of the controller turns or flashes red, an alarm is generated.

! Caution

When an alarm is generated

It is possible to check the type of the alarm by a combination of lighting-up and flashing of ALARM and POWER LEDs. Check the alarm and remove the cause of the alarm referring to the

“14. Alarm Detection Details (P.66).”

(5) Setup of the setting data (operation pattern)

Setup the target position or positioning time on the operation pattern screen (basic parameter and step data setup) by using a PC (with the controller setting software).

PC (Controller setting software)

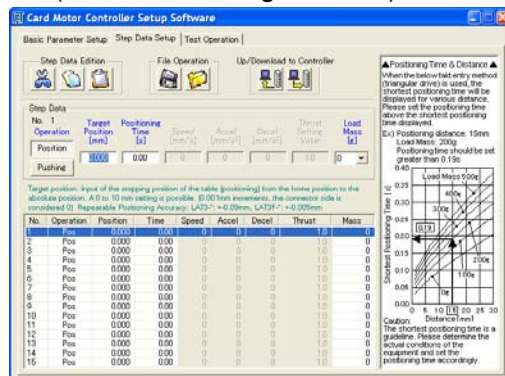

Refer to **8. Setting data entry (P.29)** and **12. Setup software details (P.49)** for setting.

(6) Test operation

Refer to **8. Setting data entry (P.29)** and **12. Setup software details (P.49)** for operation of the test drive.

3. Specifications

3.1 Basic specifications

The basic specifications of the product are described below.

Item	Specifications
Compatible motor	LAT3 and LAT3F series Card Motor
Number of Step Data	15 (absolute or relative)
Power supply specification ^(Note 1)	Power supply voltage: 24 VDC+/-10% Maximum current consumption: Rated 2 A (Peak 3 A) ^(Note 2) Power consumption: 48 W (Maximum 72 W) ^{Note2)}
Parallel input	6 inputs (Optically isolated)
Parallel output	4 outputs (Optically isolated, open collector output)
Position display output ^(Note 3)	A phase, B phase RESET signal (NPN open collector output)
LED display	2 LED's (Green and Red)
Operating temperature range	0 to 40°C (No condensation, no freezing)
Operating humidity range	35 to 85% (No condensation, no freezing)
Storage temperature range	-10 to 60°C (No condensation, no freezing)
Storage humidity range	35 to 85% (No condensation, no freezing)
Insulation resistance	Case - between FG 50 MΩ (500 VDC)
Load mass ^(Note 4)	130 g (Screw mounting type) 150 g (DIN rail mounting type)

Note 1) Do not use an inrush current limited type power supply for the controller.

Note 2) Rated current: Current consumption when continuous thrust is generated.
Peak current: Current consumption when maximum instantaneous thrust is generated.

Note 3) Specification for the connection of the separately sold CEU5 Multi-counter.

Note 4) Cables are not included.

3.2 Parts description

Details of the controller are described below.

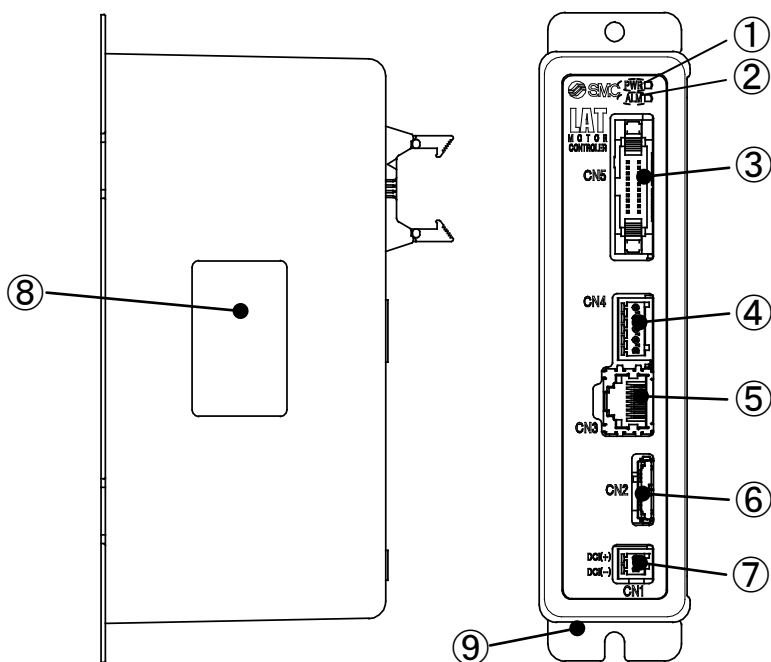

No.	Display	Name	Details
1	PWR	Power supply and alarm LED (Green)	Normal operation: Green If also the ALM LED is lit or flashes simultaneously, an error has been generated.
2	ALM	Alarm LED (Red)	In alarm condition: Lit or flashes red. The combination of lit or flashing ALM and PWR LED's indicates the content of an alarm.
3	CN5	Parallel I/O Connector (20 pins)	Connection to a PLC via the LATH2-* I/O cable. (6 inputs, common (COM) terminal for the input signals, 4 outputs, positive and negative power supply terminals for the output signals)
4	CN4	Counter connector (5 pins)	Connection to the CEU5 Multi-counter via the LATH3-* counter cable.
5	CN3	Serial I/O Connector (9 pins)	Connection to a PC via the controller setting cable.
6	CN2	Motor connector (18 pins)	Connection to the Card Motor via the LATH1-* actuator cable.
7	CN1	Power supply connector (2 pins)	24 VDC power supply connection to the controller using the power supply plug and a power supply cable.
8	-	Controller part number label	Label indicating the part number of the controller.
9	-	FG	Frame ground (When the controller is mounted, tighten screws and connect the grounding cable.)

3.3 External dimensions

Controller external dimensions.

(1) Screw mounting (LATC4-**)

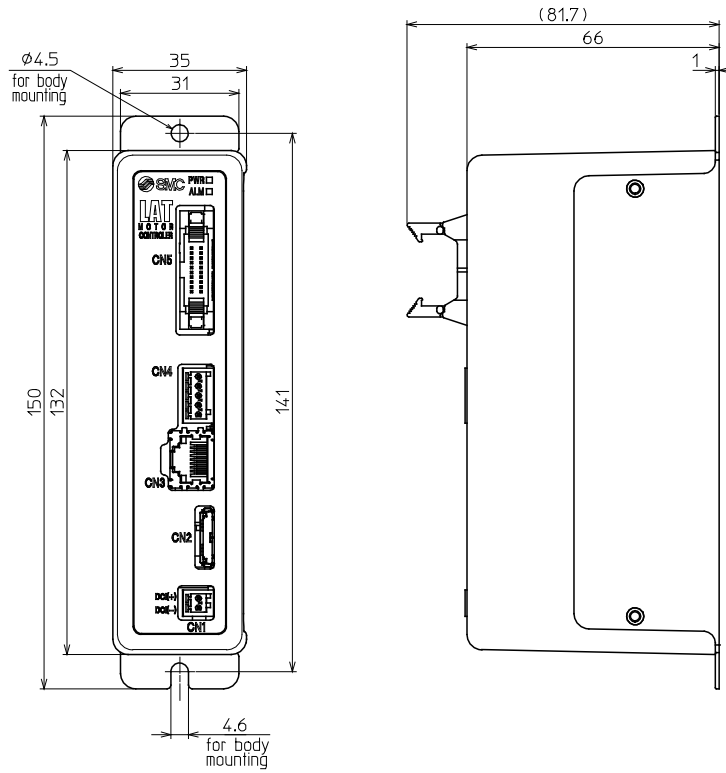

(2) DIN rail mounting (LATC4-**D)

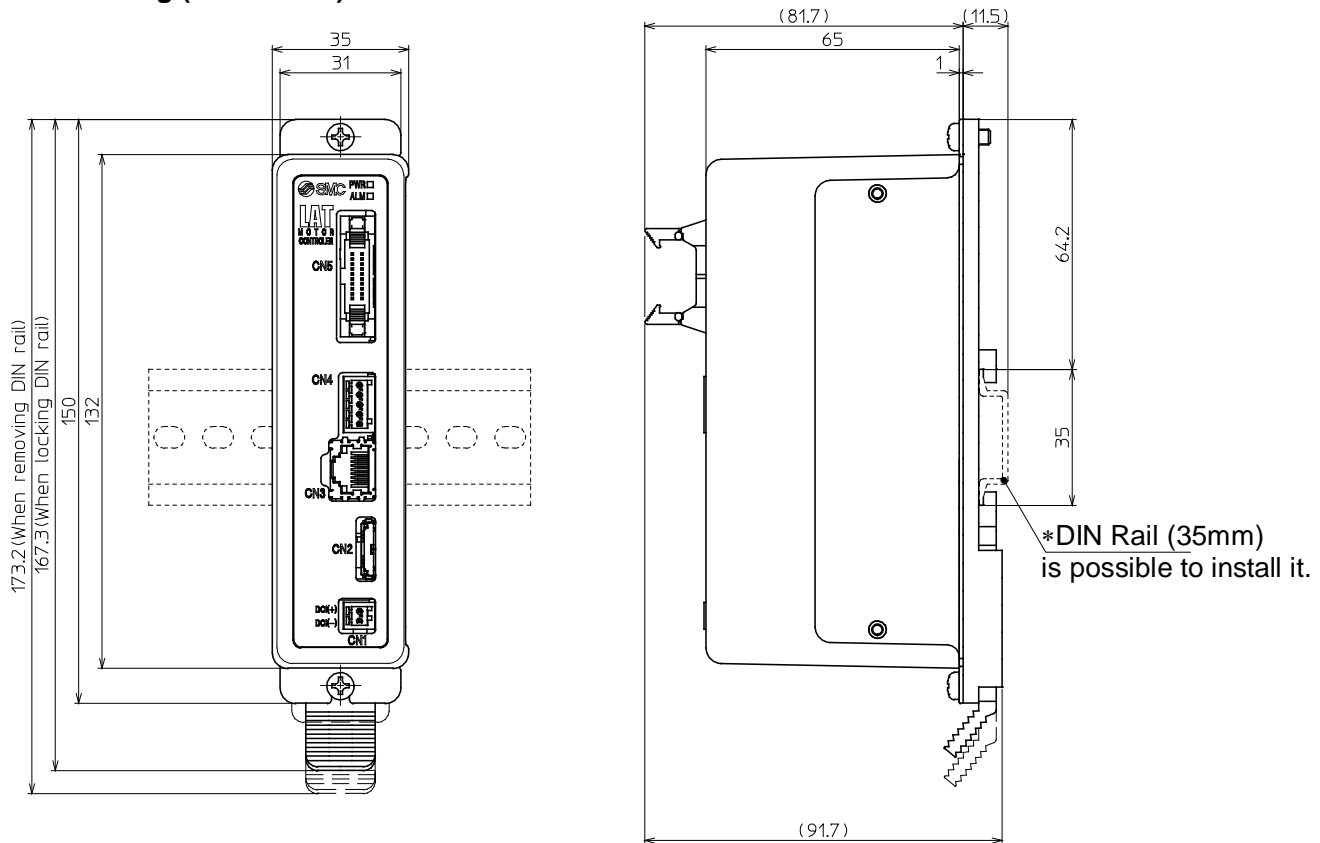

3.4 Mounting

(1) Mounting

The controller can be mounted by screws or DIN rail.

Details of the controller is shown below...

(1) Screw mounting (LATC4-**) (Mounting with two M4 screws)

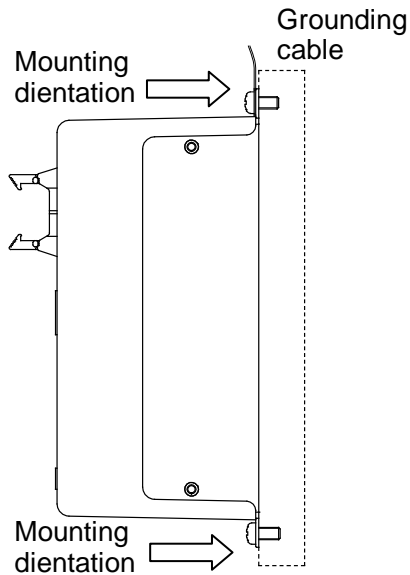

(2) DIN rail mounting (LATC4-**) (DIN rail mounting)

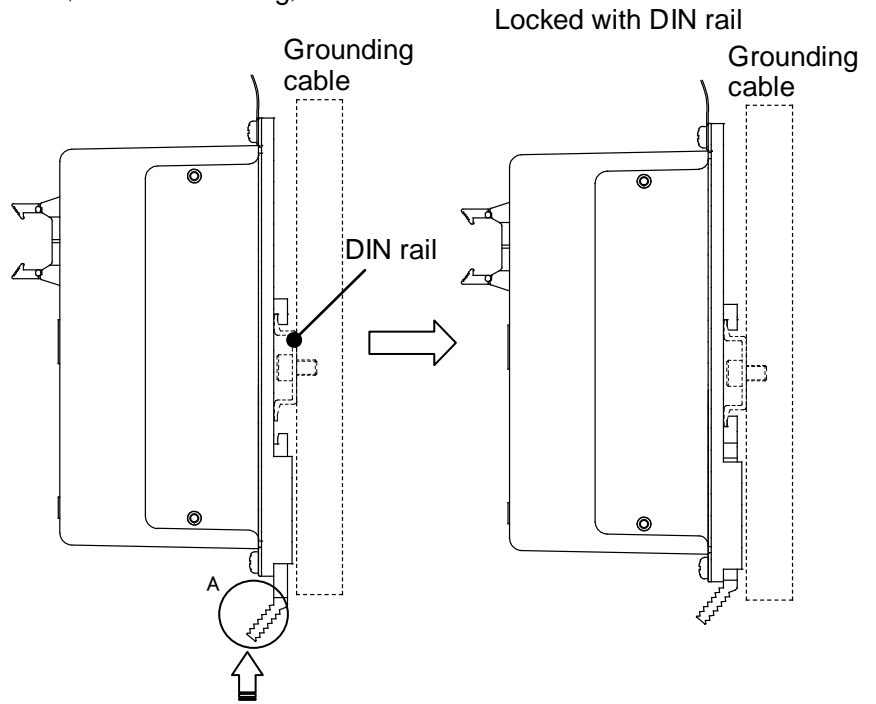

Hook the controller to DIN rail, and attach it to the rail by pushing A part in the arrowed direction.

(2) Grounding

Place the cable with the crimped terminal between the M4 screw and toothed washer as shown below and tighten the screw.

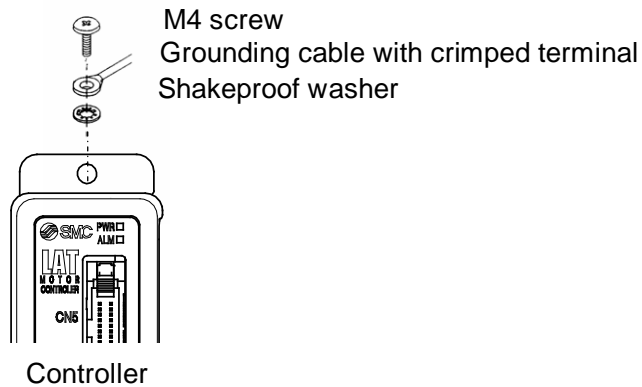

⚠ Caution

The M4 screw, cable with crimped terminal and shakeproof washer are to be prepared by the user.
Ground the controller to reduce noise.

! Caution

Dedicated grounding should be used. Grounding with the D-class ground (ground with the resistance less than 100Ω). The cross sectional area of the grounding cable shall be 2mm^2 or more.

Grounding location should be in the vicinity of the controller. Keep the grounding cable short.

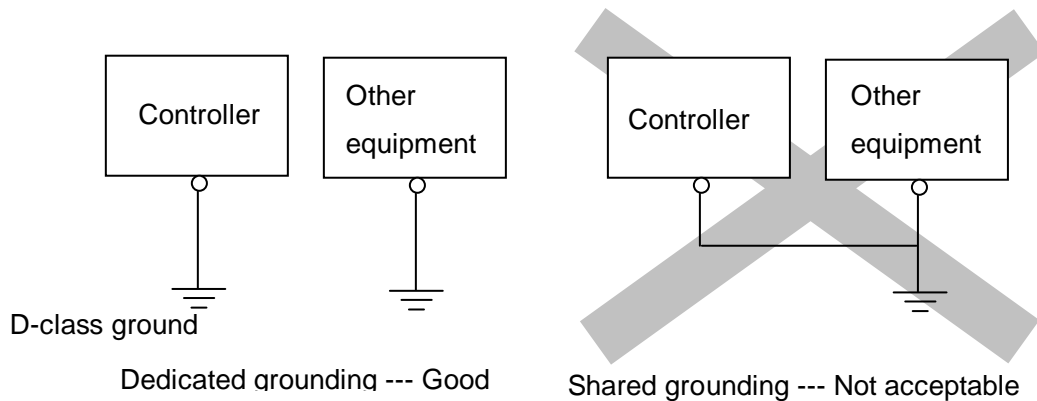

(3) Location for mounting

Take the size of the control panel and installation style into account so that the surrounding temperature of the controller is 40°C or less.

Mount the controller vertically on the wall with 30mm or 50mm more of space on the top and bottom of the controller as shown below.

Keep 60mm or more between the front of the controller and the cover (lid) for inserting and removing connectors.

Keep enough space around the controllers so that the operating temperature of the controller stays within the specification range.

Avoid mounting the controller with a vibration source, such as a large sized electromagnetic contactor or circuit fuse breaker on the same panel or keep it away from the controller.

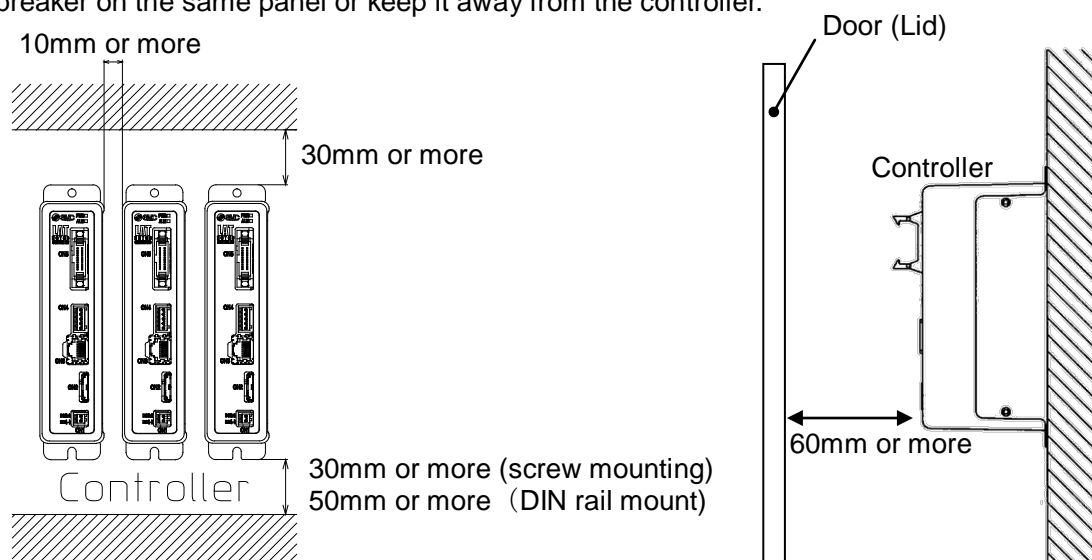

! Caution

When there are dents, bumps or warping on the mounting surface of the controller, excessive force can be applied to the case, which can cause failure. Mount on a flat surface.

4. External connection

4.1 CN1: Power supply connector

An example of standard wiring of the controller is shown for each connector (CN1 to 5).

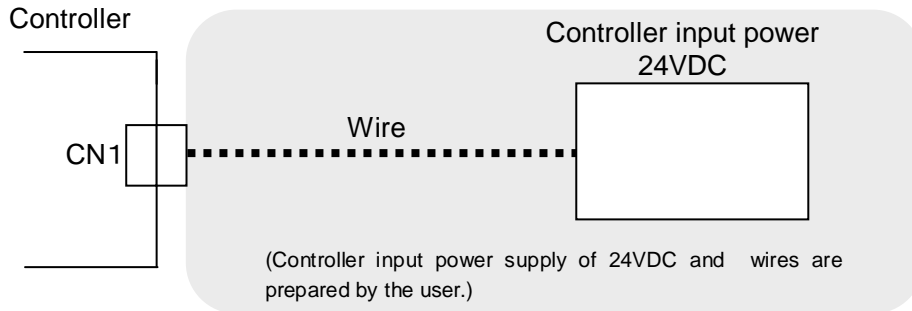

Refer to **5. CN1: Power supply plug (P.19)** for wiring.

Caution

Do not use inrush current suppressor types as the power supply for the controller input.

4.2 CN2: Motor connector

Connect the controller and the Card Motor with the actuator cable (LATH1-*).

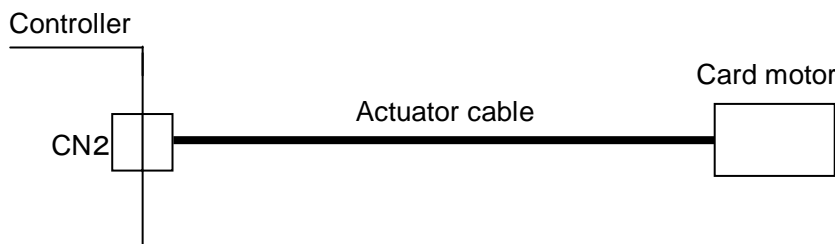

4.3 CN3: Parallel I/O connector

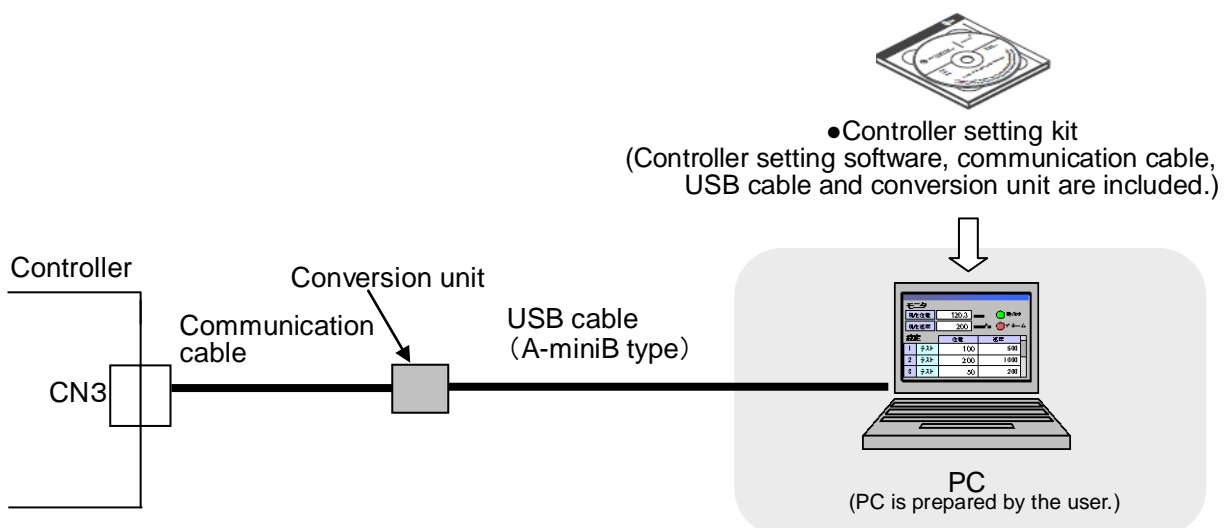

4.4 CN4: Counter connectors (Option)

Connect the controller and CEU5 Multi-counter using the LATH3-* counter cable.

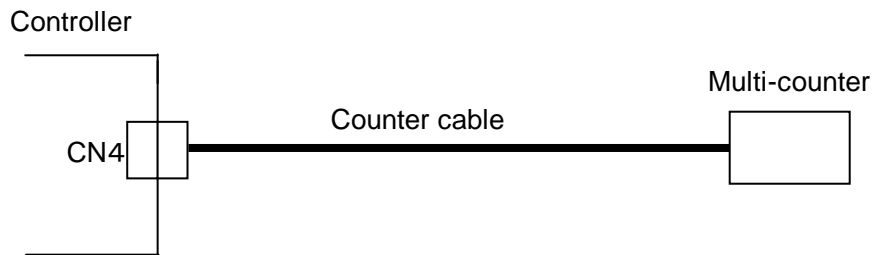

4.5 CN5: Parallel I/O connector

Connect the controller and PLC with the I/O cable (LATH2-*).

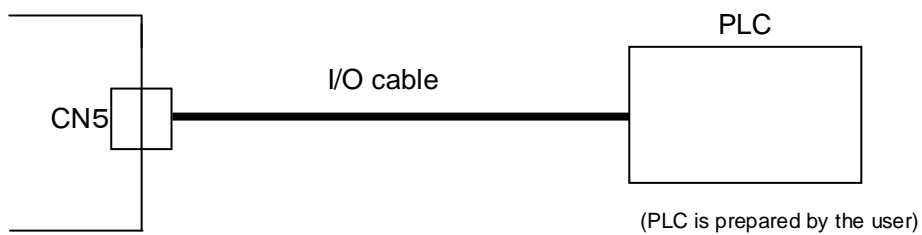

Refer to [7.4 Parallel I/O connector wiring \(P.28\)](#) for wiring.

Refer to [7.3 Parallel I/O signal \(P.24\)](#) for details of each signal of the parallel I/O.

5. CN1: Power supply plug

5.1 Power supply plug specifications

The specifications of the included power supply plug are shown below.

Power supply plug

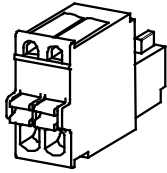

DC1(-)
DC1(+)

Terminal	Function	Functional explanation
DC1 (-)	Power supply (-)	The power supply (-) supplied to the controller. The power supply (-) is also supplied to the Card Motor via the internal circuit of the controller and actuator cable.
DC1 (+)	Power supply (+)	The power supply (+) supplied to the controller. The power supply (+) is also supplied to the Card Motor via the internal circuit of the controller and actuator cable.

5.2 Electrical wiring specifications

Electrical wiring which satisfies following specifications shall be prepared and wired by the user.

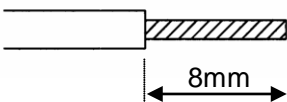
Item	Specifications
Applicable electrical wire size	20 AWG / 0.5 mm ² Use a single multi-strand wire for each terminal. Strip the ends as shown below and twist the strands together. * The rated temperature of the insulation coating should be 60°C or more.
Stripped wire length	



Caution

Do not connect multiple wires to one terminal.

After wiring the power supply plug, connect the power supply plug to CN1 power connector of the controller.

Refer to **5.3. Power supply plug (P.20)** for wiring.

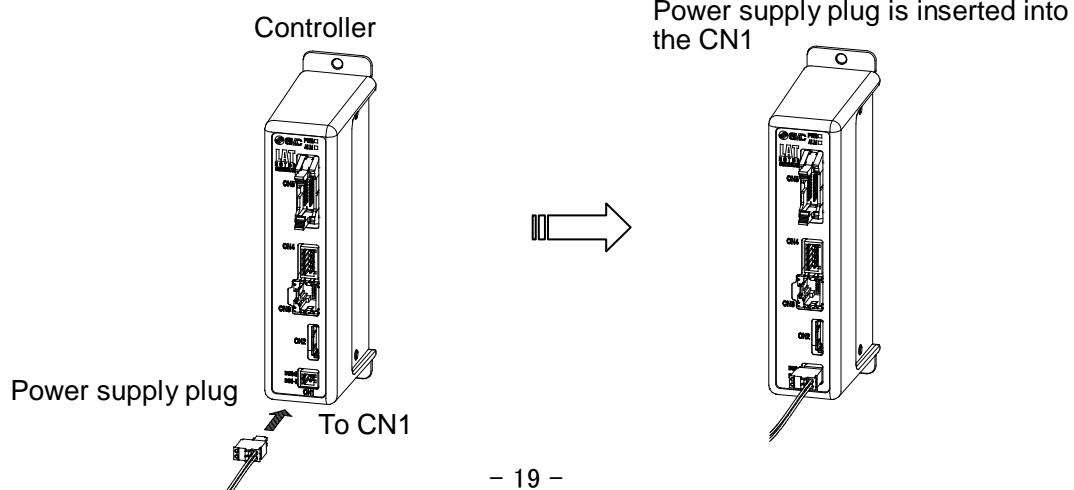

5.3 Power supply plug wiring

Connect the power supply plug included as an accessory to 24 VDC power supply of the controller and connect it to the power entry of the power supply connector.

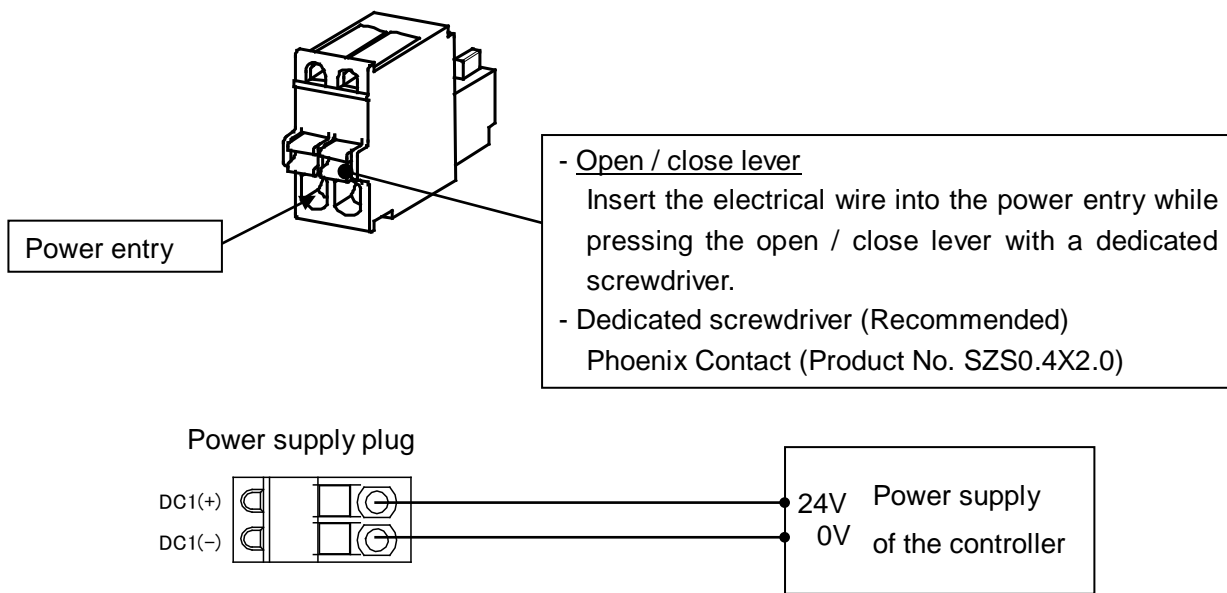

! Caution

Use a power supply which capacity is larger than the maximum instantaneous power which is described in the specification of the actuator. Do not use inrush current suppressor type as the power supply for the controller input (24 VDC).

6. CN4: Counter plug

6.1 Counter plug

The specifications of the included counter plug are shown below.

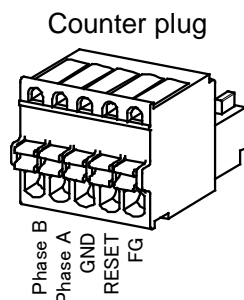

Name	Description	Wire color
Phase B	Connect to B phase of the counter cable	White
Phase A	Connect to A phase of the counter cable	Red
GND	Connect to GND of the counter cable	Light gray
RESET	Connect to Reset of the counter cable	Yellow
FG	Connect to FG of the counter cable	Green

6.2 Counter plug wiring

The wiring of the separately sold counter cable (LATH3-*) and multi-counter (CEU5) is shown below.

Refer to the operation manual (CEU5) for details.

Name	Wire color	Counter terminal
Phase B	White	B phase pulse input
Phase A	Red	A phase pulse input
GND	Light gray	Sensor input common
RESET	Yellow	Reset input
FG	Green	FG terminal
-	-	Control input common ^{note1)}
-	-	Sensor power supply output ^{note1)}

Note 1) Connect the control input common terminal (COM) to the sensor power supply output terminal (12 VDC).

Note 2) Refer to **13.3 Multi-counter (CEU5) (P.65)** for the multi-counter setting (CEU5).

7. CN5: Parallel I/O Connector

7.1 Parallel input / output

- Input specifications

Item	Specifications
Input circuit	Internal circuit and photo coupler insulation
Number of input	6 points
Power supply	+/-10 (%) of 24 VDC
Input current at ON	+/-20% of 2.4mA (at 24 VDC)
Input current / voltage at OFF	1.5 mA or less of current 15 V or less of voltage

- Output specifications

Item	Specifications
Output circuit	Internal circuit and photo coupler insulation
No. of outputs	4 outputs
Maximum voltage between terminals	30 VDC
Maximum output current	10 mA
Saturation voltage between terminals	2.0 V (Maximum)

7.2 Parallel I/O circuit (NPN, PNP)

In this controller, NPN type (LATC4-N) and PNP type (LATC4-P) are available (parallel I/O type is different between NPN type and PNP type).

(1) Parallel I/O input circuit (NPN, PNP common)

(a)	IN0<A2> to SVON<A7>
(b)	COM<A1>

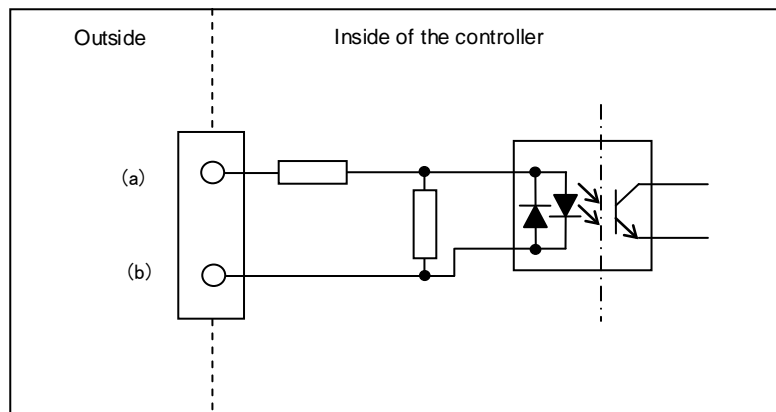

! Caution

If the input signal is not connected (open), the controller will be affected by the surrounding noise and the circuit in the controller will recognize that the controller is OFF.

Unused terminals should be connected in accordance with the operating conditions.

(2) Parallel I/O output circuit

-NPN type

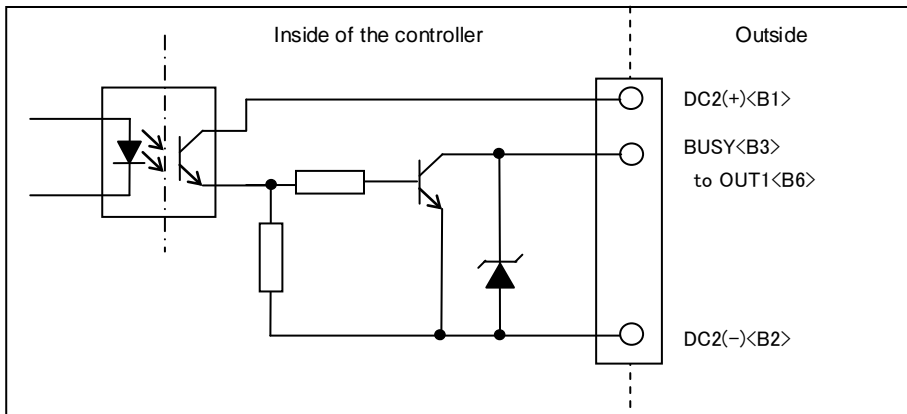

-PNP type

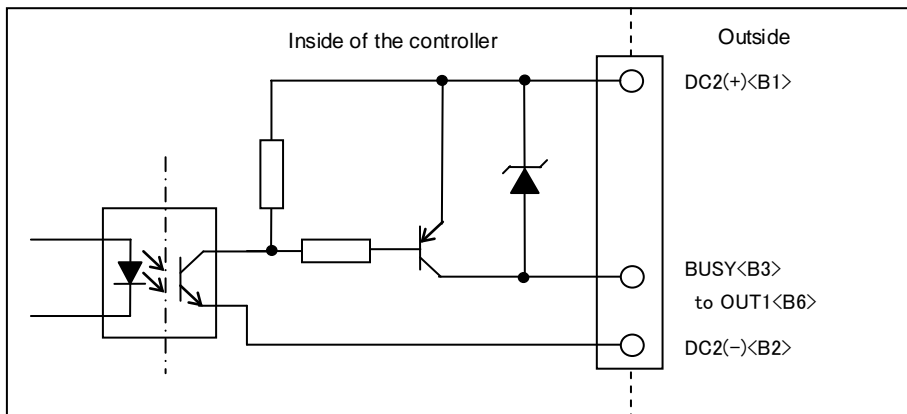

7.3 Parallel I/O signals

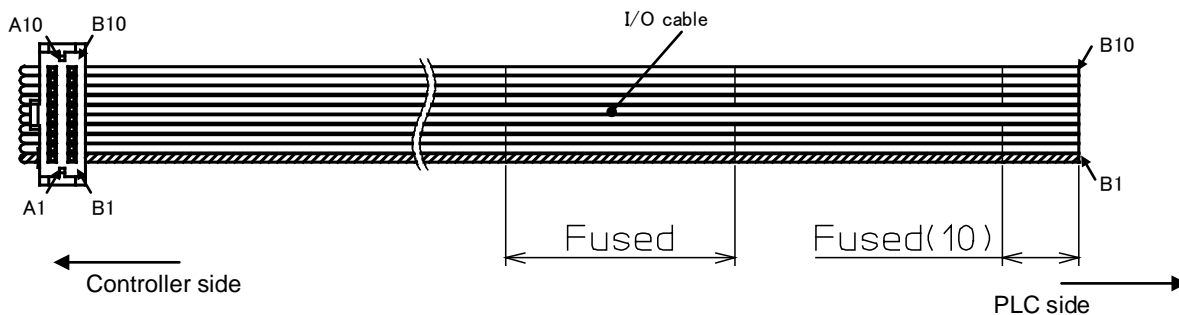

-Input side-

Terminal No.	Function	Description																												
A1	COM	Common terminal for the input signal power supply. Connect the power supply + side (+ common) or power supply - side (- common) in accordance with the wiring specifications. Either polarity can be used.																												
A2	INO	Step data assigned Bit No. (Input with the combination of IN0 to IN3) When all the Bit Nos. from IN0 to IN3 are OFF, returning to origin position is performed. (Step data No.0) Ex. (Assign step data No.3)																												
A3	IN1	<table border="1" style="display: inline-table; vertical-align: middle;"> <tr> <td>IN3</td> <td>IN2</td> <td>IN1</td> <td>IN0</td> </tr> <tr> <td>OFF</td> <td>OFF</td> <td>ON</td> <td>ON</td> </tr> <tr> <td>0</td> <td>0</td> <td>1</td> <td>1</td> </tr> </table> ← 2 Decimal number	IN3	IN2	IN1	IN0	OFF	OFF	ON	ON	0	0	1	1																
IN3	IN2	IN1	IN0																											
OFF	OFF	ON	ON																											
0	0	1	1																											
A4	IN2	<div style="text-align: center; border: 1px solid black; padding: 5px;">⚠ Caution</div> <p>Step data No. 0 is registered in returning to origin position.</p> <table border="1" style="width: 100%; border-collapse: collapse;"> <thead> <tr> <th>Step data No.</th> <th>IN3</th> <th>IN2</th> <th>IN1</th> <th>IN0</th> <th>Operation</th> </tr> </thead> <tbody> <tr> <td>0</td> <td>OFF</td> <td>OFF</td> <td>OFF</td> <td>OFF</td> <td>Return to origin position</td> </tr> <tr> <td>1</td> <td>OFF</td> <td>OFF</td> <td>OFF</td> <td>ON</td> <td rowspan="3">Operation set to each step data No.</td> </tr> <tr> <td>...</td> <td></td> <td></td> <td></td> <td></td> </tr> <tr> <td>15</td> <td>ON</td> <td>ON</td> <td>ON</td> <td>ON</td> </tr> </tbody> </table>	Step data No.	IN3	IN2	IN1	IN0	Operation	0	OFF	OFF	OFF	OFF	Return to origin position	1	OFF	OFF	OFF	ON	Operation set to each step data No.	...					15	ON	ON	ON	ON
Step data No.	IN3		IN2	IN1	IN0	Operation																								
0	OFF		OFF	OFF	OFF	Return to origin position																								
1	OFF	OFF	OFF	ON	Operation set to each step data No.																									
...																														
15	ON	ON	ON	ON																										
A5	IN3																													
A6	DRIVE	<p>When DRIVE is turned ON, the system scans the input IN0 to IN3 and starts the operation of the actuator. The position is held when the operation is stopped by turning OFF the controller and the signal is switched.</p> <div style="text-align: center; border: 1px solid black; padding: 5px;">⚠ Caution</div> <p>If DRIVE input is turned OFF during operation, an overshoot may occur depending on the condition. Turn ON this signal after inputting SVON signal and selecting the specified input signals (IN0 to 3).</p>																												
A7	SVON	<p>Specify the servo ON. [Servo ON] is an energizing command of the motor. If the servo ON is canceled, the motor will operate freely. It is possible to clear the corresponding alarm (SVON reset) by resetting the SVON signal (ON to OFF to ON).</p>																												
A8 to A10	NC	Open terminals																												

-Output side-

Terminal No.	Function	Description
B1	DC2(+)	Connect the 24V side of the power supply (24 VDC) for input / output signal.
B2	DC2(-)	Connect the 0V side of the power supply (24 VDC) for input / output signal.
B3	BUSY	<p>This output is ON when the motor is moving (during the Return to Origin operation, positioning and pushing operation).</p> <p>The signal function of the BUSY output can be changed, or the BUSY function can be assigned to other outputs as well in the "I/O Setup" window in the setting software.</p> <div style="border: 1px solid black; padding: 5px; margin: 10px 0;"> <p style="text-align: center;"> Caution</p> <p>When the motor is stopped during the pushing operation (no movement but the actuator is generating pushing thrust), the BUSY signal is OFF. However, when the Card Motor operates at a slower speed than 5 mm/s, the BUSY signal may not turn ON at all.</p> </div>
B4	ALARM	<p>ON when there are no alarms.</p> <p>OFF in alarm condition.</p>
B5 B6	OUT0 OUT1	<p>The function of the OUT0 and OUT1 outputs can be changed to the signal functions listed below in the "I/O Setup" window in the setting software. The INP signal function is set as a default for OUT0, and INF for OUT1.</p> <ul style="list-style-type: none"> - INP signal <ul style="list-style-type: none"> The output turns ON near the target position. The output condition varies depending on each operation mode. - During return to origin <ul style="list-style-type: none"> The output turns ON after the return to origin operation is completed. - During positioning operation <ul style="list-style-type: none"> The output turns ON near the target position. - During pushing operation <ul style="list-style-type: none"> The output turns ON near the target position of the pushing operation. The position during pushing operation and target position are usually different, so in that case, the output turns ON temporarily, but it turns OFF when the target position is passed. - INF signal <ul style="list-style-type: none"> Turns ON when the target position has been reached and the generated pushing force exceeds the set "Threshold Force Value" during pushing operation. It is disabled (OFF) in positioning operation both when the actuator is moving and when held in position. The "Threshold Force Value" can be set in the "I/O Setup" window in the setting software.

⚠ Caution

The "Threshold Force Value" is set in the "I/O Setup" tab as a general value for all pushing operation Step Data, and the "Thrust Setting Value" can be set individually for each Step Data.

Therefore the INF output may be activated also when the pushing force differs from the set "Thrust Setting Value".

- INFP signal

Turns ON when the current Card Motor table position has reached within the positioning repeatability range of the connected Card Motor model. The output conditions for each operation mode are similar to those for the INP signal.

- AREA signal

Turns ON when the actuator is within the output range between "Position 1" and "Position 2".

The "Position 1" to "Position 2" range can be set in the "I/O Setup" window in the setting software.

A maximum of two position ranges, "AREA A" and "AREA B", can be selected for the AREA output signal, and the "Position 1" to "Position 2" range can be set individually for each of them.

It is possible to set only one signal function per output for OUT0 and OUT1.

(e.g. OUT0 = INP, OUT1 = AREA A)

Example of AREA signal output

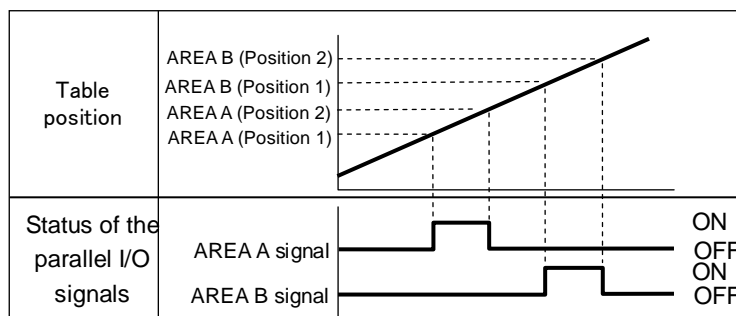

B5
B6

OUT0
OUT1

B7 to B10

NC

Open terminals

Caution

The Card Motor table is held in position and the position is read by the controller during the interval after the DRIVE signal has been activated and before the operation has started and the SVON signal has turned ON. (Positioning control)

No signal output control is carried out while the table position is being held, so the output signal status is maintained when the DRIVE signal is OFF.

Only the INF signal will turn OFF when the DRIVE signal is turned OFF.

The step data is executed according to the input signal status of IN0 to IN3 as soon as the DRIVE signal has changed from OFF to ON (operation start on rising edge).

Ensure that the power supply has been turned on and that the ALARM signal is ON before activating any input signals.

If any input signal has already been activated before the ALARM output has turned ON, turn the signal OFF once and turn it ON again.

Furthermore ensure the same I/O signal sequence and turn OFF all input signals and back ON again when operating the Card Motor with parallel I/O signals after communicating with the controller setting software.

7.4. Parallel I/O connector wiring (Example)

Use the I/O cable (LATH2-*) for connecting PLC with the parallel I/O connector.

Wiring depends on the parallel input/output of the controller (NPN, PNP type).

Please wire the product referring to the wiring diagram below.

- NPN type

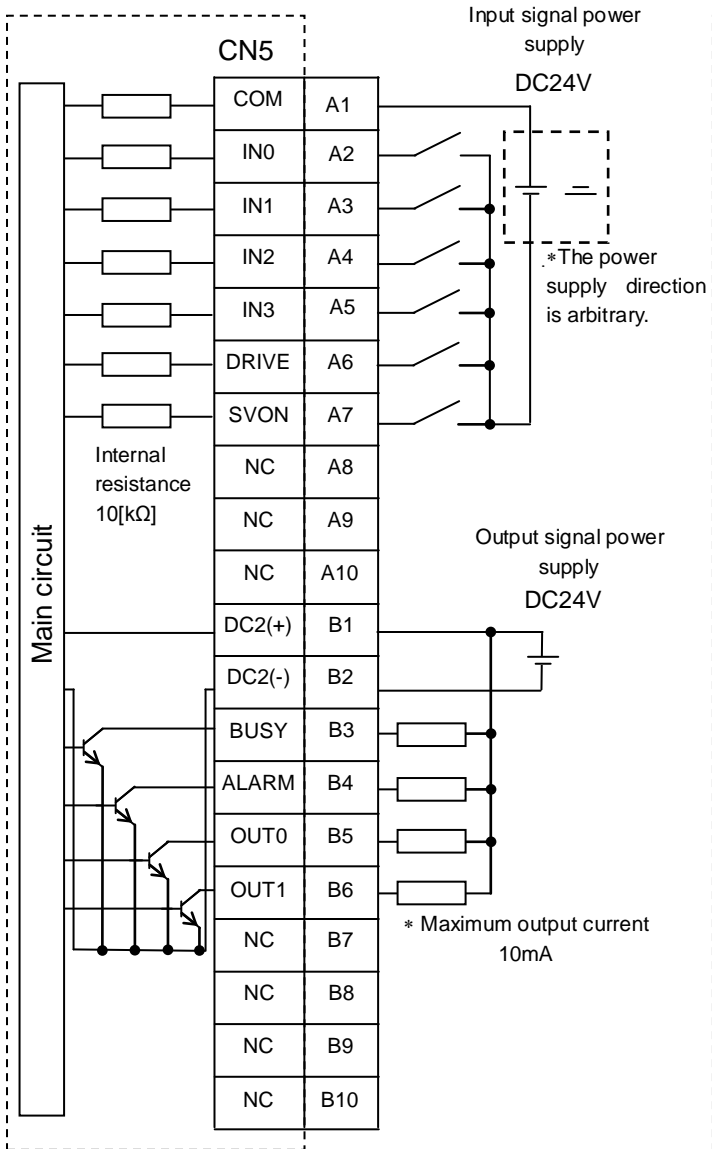

-PNP type

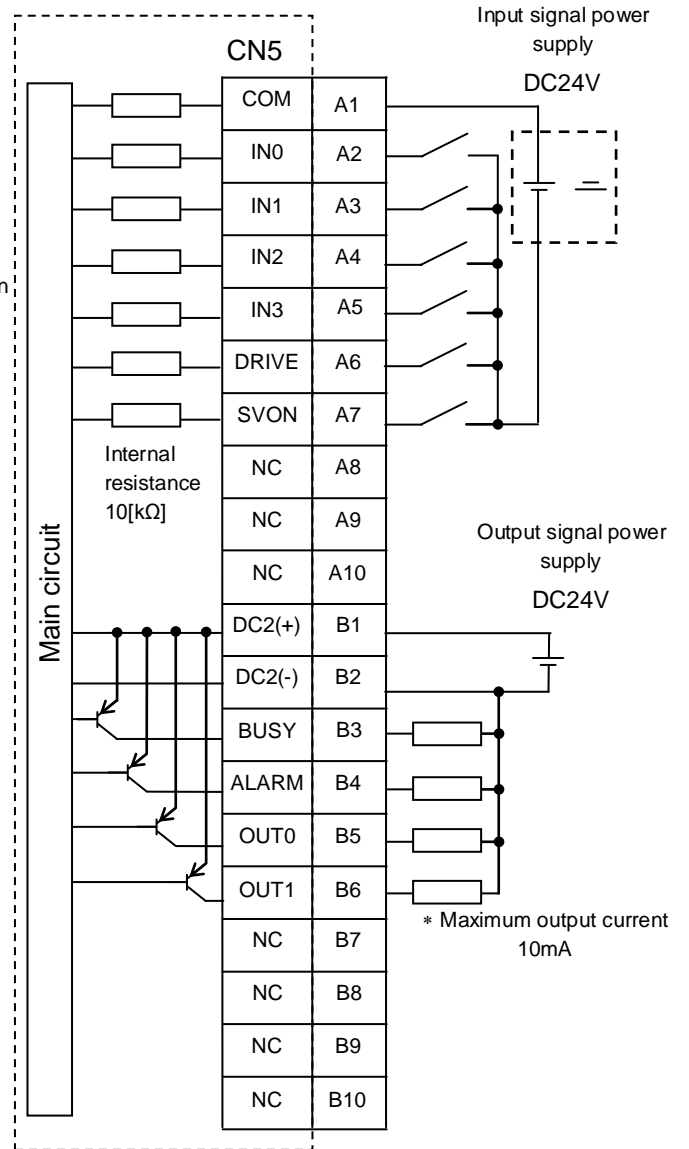

⚠ Caution

Prepare separate 24 VDC power supplies for the CN1 controller power supply and CN 5 input / output signal power supply).

8. Settings and Data Entry

In order to move the Card Motor to a specific position, it is necessary to program the operation patterns in the controller using a PC with the controller setting software installed.



The data entered using the controller setting software are saved in the memory of the controller.

With the controller setting software the [I/O Setup], [Basic Parameter Setup], [Step Data Setup] can be set and [Monitor/Test] operations can be performed.

8.1 Basic parameter setup

The “Basic Parameter Setup” window includes data that defines the operating conditions of the controller or the actuator, etc.

Basic parameter setup

Name	Input range	Description														
Card Motor product number	6 options (See the “Description” column on the right for a list of available options)	Set according to the connected motor type. <table border="1"> <thead> <tr> <th>Product No.</th> <th>Specifications</th> </tr> </thead> <tbody> <tr> <td>LAT3-10</td> <td>Stroke 10 mm, resolution 30 μm</td> </tr> <tr> <td>LAT3-20</td> <td>Stroke 20 mm, resolution 30 μm</td> </tr> <tr> <td>LAT3-30</td> <td>Stroke 30 mm, resolution 30 μm</td> </tr> <tr> <td>LAT3F-10</td> <td>Stroke 10 mm, resolution 1.25 μm</td> </tr> <tr> <td>LAT3F-20</td> <td>Stroke 20 mm, resolution 1.25 μm</td> </tr> <tr> <td>LAT3F-30</td> <td>Stroke 30 mm, resolution 1.25 μm</td> </tr> </tbody> </table>	Product No.	Specifications	LAT3-10	Stroke 10 mm, resolution 30 μm	LAT3-20	Stroke 20 mm, resolution 30 μm	LAT3-30	Stroke 30 mm, resolution 30 μm	LAT3F-10	Stroke 10 mm, resolution 1.25 μm	LAT3F-20	Stroke 20 mm, resolution 1.25 μm	LAT3F-30	Stroke 30 mm, resolution 1.25 μm
Product No.	Specifications															
LAT3-10	Stroke 10 mm, resolution 30 μm															
LAT3-20	Stroke 20 mm, resolution 30 μm															
LAT3-30	Stroke 30 mm, resolution 30 μm															
LAT3F-10	Stroke 10 mm, resolution 1.25 μm															
LAT3F-20	Stroke 20 mm, resolution 1.25 μm															
LAT3F-30	Stroke 30 mm, resolution 1.25 μm															
Returning to origin position	3 options (See the right descriptions)	Select the operating direction at return to origin position. <table border="1"> <thead> <tr> <th>Method to return to origin position</th> </tr> </thead> <tbody> <tr> <td>Retracted end position (connector side) Manually slide the table to the connector side and set the position as "0".</td> </tr> <tr> <td>Extended end position Manually slide the table to the opposite side of the connector and set the position as maximum stroke.</td> </tr> <tr> <td>Sensor origin Manually slide the table to the built in sensor's origin position and set this point.</td> </tr> </tbody> </table>	Method to return to origin position	Retracted end position (connector side) Manually slide the table to the connector side and set the position as "0".	Extended end position Manually slide the table to the opposite side of the connector and set the position as maximum stroke.	Sensor origin Manually slide the table to the built in sensor's origin position and set this point.										
Method to return to origin position																
Retracted end position (connector side) Manually slide the table to the connector side and set the position as "0".																
Extended end position Manually slide the table to the opposite side of the connector and set the position as maximum stroke.																
Sensor origin Manually slide the table to the built in sensor's origin position and set this point.																
Step data input version	Cycle time entry method Speed entry method	Cycle time entry method: Enter the target position, positioning time and load mass. Speed entry method: Enter the target position, speed, acceleration, deceleration and load mass.														
Card Motor mounting orientation	Horizontal Vertical	Select the Card Motor mounting orientation. Horizontal: The angle of the Card Motor connector is 0 to 45° to the horizontal surface. Vertical: The angle of the Card Motor connector is 46 to 90° to the vertical surface.														
Setup	-	The changed value is sent to the controller connected to the PC. <table border="1"> <thead> <tr> <th> Caution</th> </tr> </thead> <tbody> <tr> <td>To reflect the setting, execute the controller reset operation before operating the Card Motor. The execution of the reset operation is displayed on the setting software window.</td> </tr> </tbody> </table>	 Caution	To reflect the setting, execute the controller reset operation before operating the Card Motor. The execution of the reset operation is displayed on the setting software window.												
 Caution																
To reflect the setting, execute the controller reset operation before operating the Card Motor. The execution of the reset operation is displayed on the setting software window.																

8.2 Step Data Setup setting method and movement profiles

To program the step data, there are two entry methods in the Card Motor controller as described below.

Name	Description
Cycle time entry method	When it is necessary to operate the table based on the positioning time or frequently. When the positioning time is set, the speed, acceleration and deceleration are calculated automatically to position the table.
Speed entry method	When the table is positioned with a constant speed. The table is positioned based on the already set speed, acceleration and deceleration.

(1) Cycle time entry method

Settings: , ,

To obtain the total travel distance S [mm] in absolute positioning mode, calculate the difference between the position from where the table travel starts to the target position. The table will move to the Target Position within the set Positioning Time T_p [s] according to a triangular movement profile as shown in the diagram on the right to.

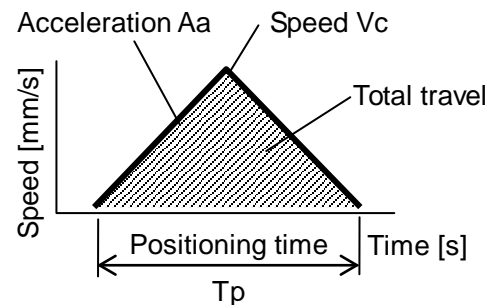

In relative positioning mode the travel distance S [mm] is equal to the Target Position.

The positioning time should be larger than the minimum positioning time shown below taking the load mass during operation into account. If there is overshoot or vibration, set the positioning time longer.

LAT3-* Relationship between positioning time and total travel distance

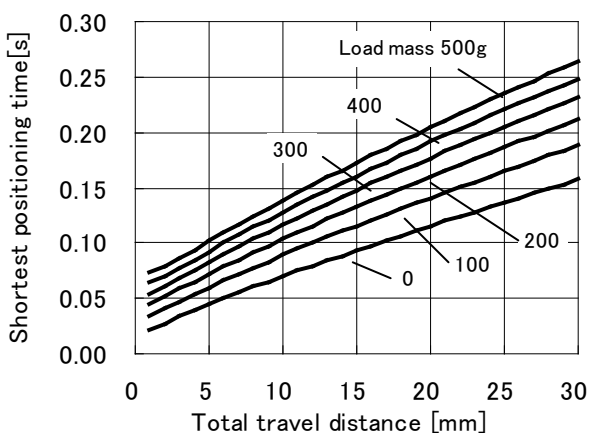

LAT3F-* Relationship between positioning time and total travel distance

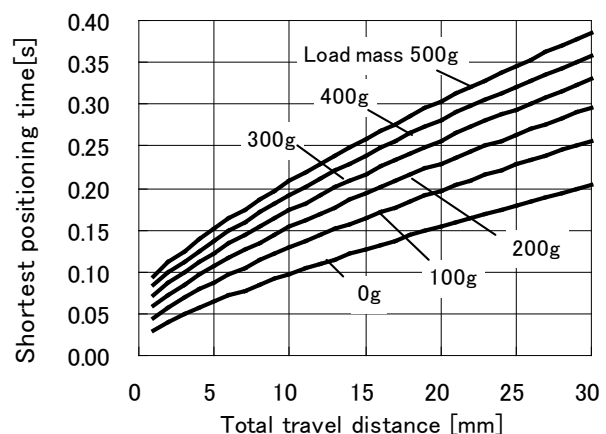

(2) Speed entry method

Settings: , , , ,

To obtain the total travel distance S [mm] in absolute positioning mode, calculate the difference between the position from where the table travel starts to the target position. The table will move to the Target Position according to a trapezoidal movement profile as shown in the diagram on the right based on the set speed V_c [mm/s], acceleration A_a [mm/s²] and deceleration A_d [mm/s²].

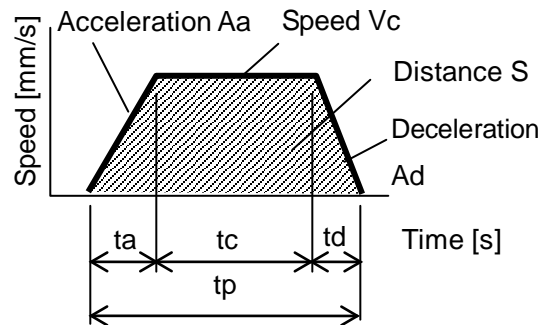

In relative positioning mode the travel distance S [mm] is equal to the Target Position.

See the equations below for the acceleration time, constant velocity time and travel distance.

Acceleration time: $t_a = V_c / A_a$ [s]

Deceleration time: $t_d = V_c / A_d$ [s]

Travel time by the acceleration time: $S_a = 0.5 \times A_a \times t_a^2$ [mm]

Travel time by the deceleration time: $S_d = 0.5 \times A_d \times t_d^2$ [mm]

Travel time with constant velocity: $S_c = S - S_a - S_d$ [mm]

Constant velocity time: $t_c = S_c / V_c$ [s]

Positioning time: $t_p = t_a + t_c + t_d$ [s]

(For Cycle time, add settling time to the total travel time.)

The acceleration and deceleration should be smaller than the maximum acceleration based on the maximum acceleration shown in the right figure taking the load mass during operation into account.

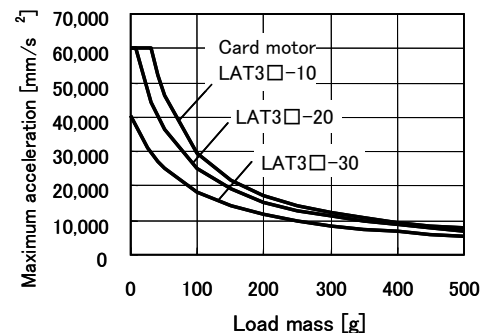

Caution

If acceleration and deceleration is small, the table might not operate with the set speed due to the triangle operation.

Movement modes

The target positions can be specified as absolute or relative positions.

Absolute positioning

The Target Position is determined based on the "Origin Position" at the retracted end. An example is shown below.

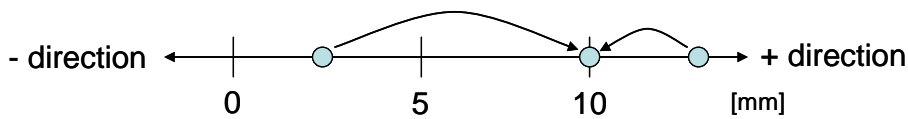

This example shows the Target Position set at 10 mm. The table of the Card Motor moves to 10 mm from any point.

Relative positioning

The Target Position is determined based on the current position. An example is shown below.

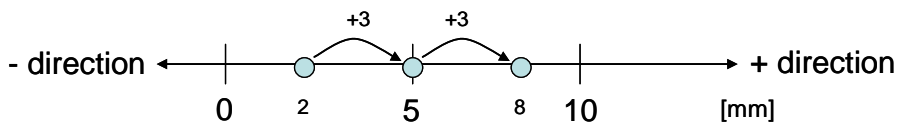

This example shows the Target Position set at +3 mm. The table moves +3 mm from the current position.

When the destination exceeds the stroke end as shown in the figure below, the table motion will be limited at the end of the stroke, and the INP or INFP signals will not be output. (No alarm will be generated.)

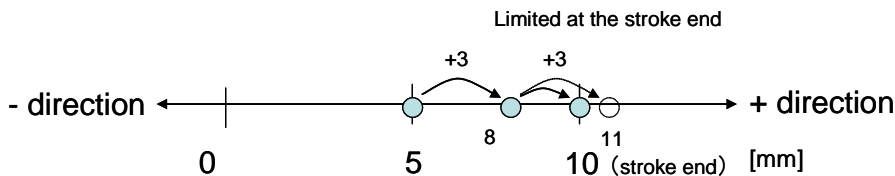

The Card Motor performs relative positioning operations as shown below if the table starts from a position outside of the software stroke range, for example when the table has reached the mechanical end stop in pushing operation or when it has been moved by an external force without the Card Motor being energized.

- If the target position is within the software stroke range:
 - The table moves the set travel distance from the current position.
- If the target position is outside of the software stroke range:
 - In "positioning" operation the table maintains the current position.
 - In "pushing" operation the table performs the pushing operation with the set Thrust Setting Value in the pushing direction from the current position.

The table moves when the target position is within the available stroke range.

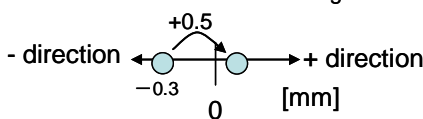

The table stays in the current position when the target position is outside the available stroke range.

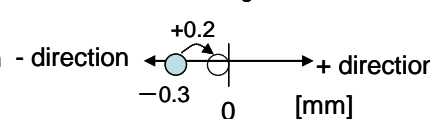

If the target position is outside of the software stroke range in pushing operation the Card Motor performs the pushing operation in the extended direction from the current position.

→ pushing operation.

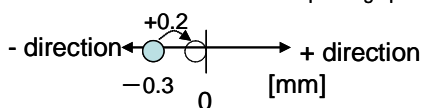

⚠ Caution

In relative positioning the deviation will remain. Therefore the table destination may be shifted because of this deviation.

Carefully check the initial position of the Card Motor table before starting relative positioning.

8.3 Step Data setup

A "step data" is the setup data mainly describing the movement of the motor. Total 15 step data (2 types) can be handled with this controller.

Step Data details

Name	Input Scope	Description						
Editing of Step Data	Cut Copy Paste	Cut: Cuts the selected step data. Copy: Copies the selected step data. Paste: The copied or cut data is pasted to the selected step data.						
Reading of the current position	Read current position	Reads the current table position, and pastes it to the "Target position". It is necessary to perform return to origin before this function can be used. The position can be pasted to the step data only in "Absolute" movement mode.						
File operation	Save Open	Save: Saves the step data in the file. Open: Reads the step data from the file.						
Up/Download to controller	Upload Download	Upload: Displays the data from the controller within the setting software (PC). Download: Rewrites the controller from the setting software with the data displayed within the setting software (PC).						
No.	1 to 15	Specifies the step data No..						
Operation selection	Positioning Pushing	Select [Positioning] or [Pushing]. (Selected button is inactive (grayed out).) When [Positioning] is selected, it is not possible to enter [Thrust setting value]. When [Pushing] is selected, it is possible to enter [Thrust setting value].						
Movem mode	Absolute Relative	Specifies the coordinate system for the target position. <table border="1" data-bbox="544 1106 1431 1352"> <thead> <tr> <th>Operation mode</th> <th>Details</th> </tr> </thead> <tbody> <tr> <td>Absolute</td> <td>The target position will be defined in relation to the absolute origin point.</td> </tr> <tr> <td>Relative</td> <td>The target position will be relative to the current position.</td> </tr> </tbody> </table>	Operation mode	Details	Absolute	The target position will be defined in relation to the absolute origin point.	Relative	The target position will be relative to the current position.
Operation mode	Details							
Absolute	The target position will be defined in relation to the absolute origin point.							
Relative	The target position will be relative to the current position.							
Target position	Absolute positioning setting ranges [mm] 0 to 10 0 to 20 0 to 30 Relative positioning setting ranges [mm] -10 to 10 -20 to 20 -30 to 30	Set the target position or position to start pushing. (Unit: mm) The input range varies depending on the Card Motor product number selected in the basic parameter setup. The target position ranges vary depending on the used movement mode. Negative values can be entered only in relative positioning mode. <div data-bbox="531 1592 1431 2022" style="border: 1px solid black; padding: 5px; margin-top: 10px;"> <p style="text-align: center;"> Caution</p> <p>The Card Motor does not move when the travel distance is shorter than the positioning repeatability range. In absolute positioning mode, the difference between the set "Target Position" and the current position, and in relative positioning mode, the set "Target Position" should be equal to or larger than the values shown below. LAT3-*: ±0.09 mm LAT3F-*: ±0.005 mm When the travel distance is shorter than the positioning repeatability range in pushing operation, the table starts moving at a constant speed in the extended direction from from the current position to perform pushing operation.</p> </div>						

Positioning time	0 to 60	<p>The positioning time to the target position is set. (Unit: s) It does not perform the positioning control when it is set to "0".</p> <p style="text-align: center;">⚠ Caution</p> <p>The operation may not be able to possible depending on the order for calling the step data. In such a case, an alarm goes off and the operation does not start. Be sure to check the operating environment sufficiently before setting.</p>
Speed	1 to 400	<p>The speed to move to the target position or pushing start position is set. (Unit: mm/s) It is possible to enter the speed when [Step date input version] is selected in [Step data entry method].</p> <p style="text-align: center;">⚠ Caution</p> <p>When parameters which cannot be realized are set, the controller might not operate in accordance with the set conditions. Similar caution is applied to the setting of accel and decel.</p>
Accel	1 to 60000	<p>Set acceleration to reach to travel speed. (Unit: mm/s²) It is possible to enter the acceleration when [Speed entry method] is selected in [Step data entry method].</p>
Decel	1 to 60000	<p>Set deceleration to reach to travel speed. (Unit: mm/s²) It is possible to enter the deceleration when [Speed entry method] is selected in [Step data entry method].</p>
Thrust setting value	1 to 5 1 to 4.8 1 to 3.9	<p>Set the maximum force for the pushing operation.</p> <p style="text-align: center;">⚠ Caution</p> <p>The thrust setting value will be a guideline, so be sure to check the operation sufficiently before setting and using the Card Motor and controller.</p>
Load mass	0 to 500	<p>Select the load mass mounted on the motor. (Unit: g) The load mass setting of Step data No. 1 is common with the return to origin operation and jog operation. Operate the Card Motor under the same load conditions for the return to origin operation and Step Data No.1. Set the load mass in Step data No.1 when the Card Motor is jogged with a load mounted.</p> <p style="text-align: center;">⚠ Caution</p> <p>The selected load mass will be a guideline, so be sure to check the operation sufficiently before setting and using the Card Motor and controller.</p>

8.4 Monitor/Test

In the "Monitor/Test" window the Card Motor status can be monitored and the performance tested.

Monitor mode: The Card Motor status can be monitored from the computer when the Card Motor is operated with parallel I/O signals.

Test operation mode: Test operation can be performed by controlling the Card Motor from the connected computer.

The four operations [Jogging], [Inching], single [Step data operation] and [Continuous operation] cycles can be performed in the test mode.

Test operation

Name	Description
Status display	Displays the current parallel I/O status.
Alarm reset	Displays the alarm history saved in the controller, and the alarm history can be reset.
Step Data No.	Displays the Step Data No. that is currently being executed.
Current position	Displays the current position of the Card Motor table.
Current speed	Displays the current speed of the Card Motor table.
Current pushing force	Displays the current pushing force of the Card Motor.
Test mode/Monitor mode	Switches between Test mode and Monitor mode.
Servo Off / Servo On	When this is clicked an energizing command of the Card Motor is sent to the controller. When this is clicked once again an energizing cancel command of the Card Motor is sent to the controller.
Return to origin / RETR	When the button is clicked, return to origin position command is sent to the controller immediately. After return to origin position is completed, the requirement to execute this function again is canceled automatically. Select the method for the return to origin position operation from the [Method to return to origin position] menu in the Basic Parameter Setup window. Note that the controller needs to be restarted after that the [Method to return to origin position] has been changed and the [Setup] button clicked for the change to come into effect.
Jogging	While this button is being pressed, the table moves at the set speed . When the button is released, the Card Motor stops moving. The right button is for the + direction (towards the extended side), and the left button is for the - direction (towards the retracted side).
Speed	Sets the speed for jogging and inching. Setting range: from 1 to 100 mm/s. (Depending on the operating conditions, the set speed may not be achieved.)
Inching	The Card Motor moves the distance that is specified in the "Move Distance" text box at the set moving "Speed". (Moving "Speed" is common with Jogging.) The table moves in the + direction (towards the extended side) when the + button is clicked, and in the - direction (towards the retracted side) when the - button is clicked.
Move distance	Setting range and minimum distances for inching. LAT3-*: 0.09 mm to maximum stroke [mm] (in increments of: 0.03 mm) LAT3F-*: 0.005 mm to maximum stroke [mm] (in increments of: 0.001 mm)
 Caution	
For LAT3F, the set value will be rounded off to the nearest decimal of the positioning resolution of 0.00125 mm.	

Step data selection	<p>The signal is sent to the controller by selecting the step data and turning ON and OFF the [Servo ON] button and [Operation start / Operation stop] button.</p> <p>When the operation according to the step data is temporarily stopped, turn ON the [Operation stop] button and when that is discontinued, turn ON [Servo off].</p> <p>It is possible to select the step data as referring to each parameter saved in the controller with the [Browse] button.</p> <p>When the [Return to Origin] is pressed, the motor returns to the return to origin position direction specified by the basic parameter setup.</p> <div style="border: 1px solid black; padding: 5px; text-align: center;">  Caution </div> <p>When changing the step data to be executed, press the [Operation stop] button and stop the Card Motor first.</p>
Operation start	Start the selected step data operation.
Operation end (stop)	Stops the operation and the position is held.
Step data No.	<p>Select the step data No. to be executed (return to origin position, step data and end) from the pulldown menu. (It is possible to select from the [Browse] button.)</p> <p>When [End] is selected, the step data No. input values after that become invalid.</p>
Operating time	<p>Set the time how long the controller takes until the step data operation completes. (Unit : second) After the Card Motor controller operation is specified, the next data is executed when there is response from the controller that the execution command has been received after the set time had passed.</p> <p>When performing the return to origin position, the operation completion time should be set between 6.0 to 10.0 seconds. For Step data, enter a value that is longer than the time required for the Step data operation to be completed and is equal to or shorter than 60.0 seconds.</p>
One time operation	When this item is checked, only the initial cycle of continuous execution is executed and second and later will be skipped.
Repeat Count	<p>Enter the continuous operation count of a series of step data selected in the continuous operation with a positive number not more than 100.</p> <p>When executing the operation only one time, the repeat count should be "0".</p>
Continuance	<p>When this item is checked, a series of step data selected in the continuous operation is repeated until [Operation end (Power Off)] is pressed.</p> <p>In this operation, the input value of [Repeat Count] becomes invalid.</p>
Operation start	Execute the return to origin position and step data selected from step 1.
Operation end (Power Off)	Stop the power supplied to the Card Motor.

Caution

The operation may not be executed depending on the step data setting. In such a case, the controller may not operate due to alarm or as required.

Be sure to check the operation sufficiently in trial etc. before using the product.

Terminate other programs running on the computer before starting a test operation.

Some functions of other softwares running simultaneously on the computer, may cause the CPU of the computer to overload during communication between the controller and the computer, and this may cause the Card Motor to malfunction and it will not operate according to the settings.

Terminate other applications before operating the Card Motor controller.

9. Operations

9.1 Return to origin position

The Card Motor uses an incremental type sensor (linear encoder) to detect the table position. Therefore, it is necessary to return the table to the origin position after supplying the power. (To ensure the position of origin)

There are three [Return to origin position] methods as stated below. In any of the methods, the position of the table in the controller will be 0 (origin position) when the table is placed on the connector side. When the table moves to the connector opposite side, the position of the table in the controller is added.

Name	Description
Retracted End Position (connector side) (Recommended)	The origin position is set to [Retracted end position] in the initial condition. Move the table to the connector side and set the position 0.3 mm away from the table end as the origin position. After [Return to origin position] is completed, the table stops at the origin position.
Extend End Position	When the table of the Card Motor is stopped by the jig of the equipment on which the Card Motor is mounted, and the position is set to the origin position. The table is moved to the opposite side of the connector and the position where the table returns from the table stopped position to the connector side by a stroke of $A+0.3\text{mm}$ is set to the origin position. After [Return to origin position] is completed, the table stops at the maximum stroke end.
Sensor origin	This is used to calculate repeatability of the origin position. Only LAT3F-* which has [origin position signal] in the sensor can be used. The table is moved to the origin position according to the signal sent from the sensor installed in the sensor, and the position where the table returns from there to the connector side by a certain dimension J is set to the origin position. After [Return to origin position] is completed, the table stops at the origin position.

If the table returns to the origin position from the position where it is stopped by the stopper installed in the Card Motor (end stopped mechanically), the origin position will be set to the position shown below.

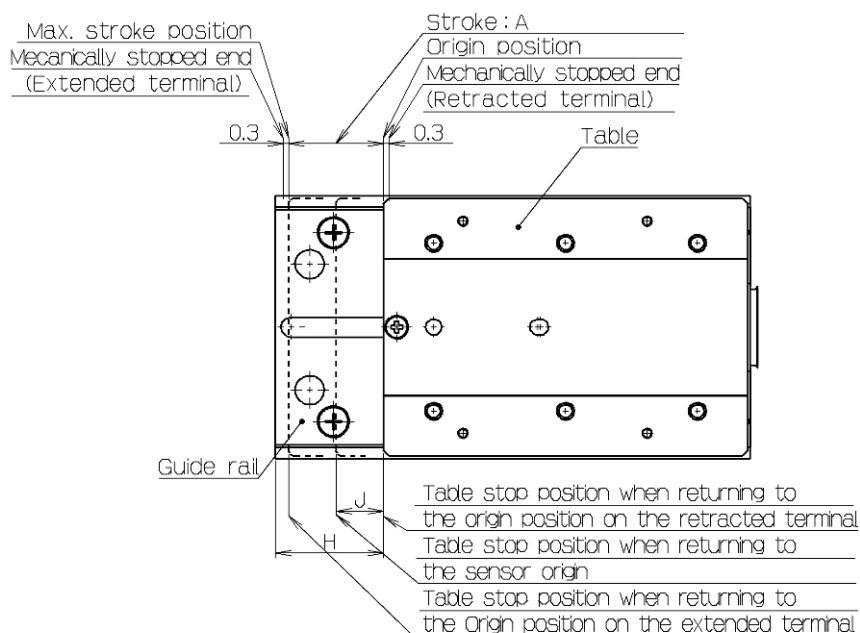

– Return to origin position

The Card Motor travels to the origin position from the position when the power was supplied. (direction set by basic parameter setup) --- Figure below "(1)"

The Card Motor travels to the stroke end and stops for a specific time after it is stopped, then the controller recognizes that the position is the motor side. After that, the actuator travels to the opposite side of the origin position at low speed. --- Figure below "(2)"

The position after the travel is set to the origin position.

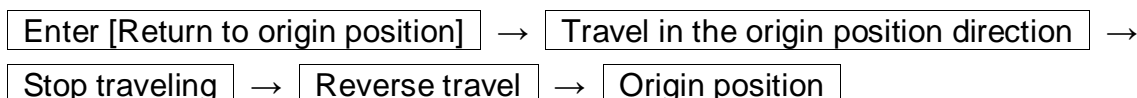

(Ex) Return to origin position

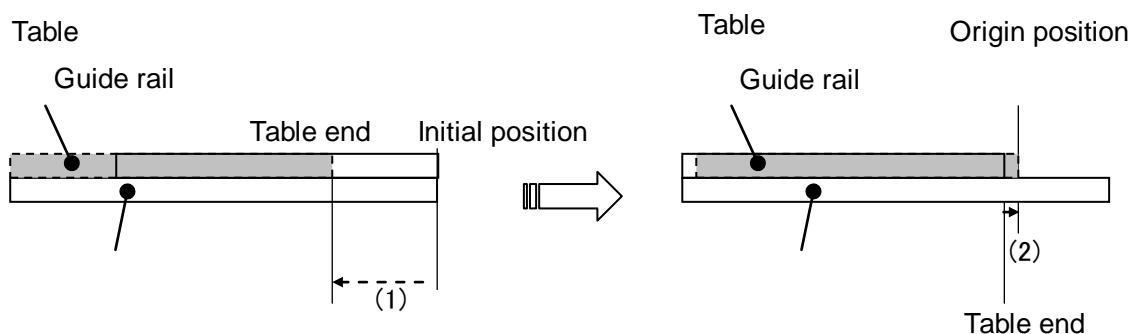

* The load mass setting for the return to origin operation is common with the load mass setting for Step Data No.1.

Confirm that the load mass setting of Step Data No. 1 corresponds to the applied load when returning to origin.

⚠ Caution

The direction of the actuator's return to origin position varies depends on the setting.

The origin position varies depending on the method to return to origin position.

Please adjust it with a real machine.

When the LAT3F series is selected, it is possible to return to the sensor origin.

The sensor origin varies depending on the stroke.

Refer to the Card Motor specifications for details.

When it bumps to the treatment device and work and the starting point returns, the starting point position might be set outside the movement range.

Please do not set the target position of the step data outside a movable range of the Card Motor.

Work and the Card Motor might be damaged.

9.2 Positioning operation

The "positioning" is registered in [Step data] - [Operation], the positioning operation is executed.
Travels to the target position set by [Step data] - [Target position].

- Positioning (ex.)

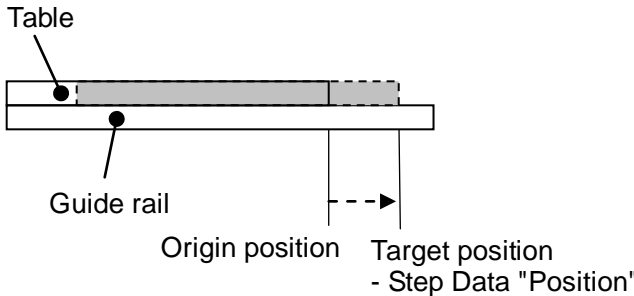

- Positioning [Cycle time entry] (ex.)

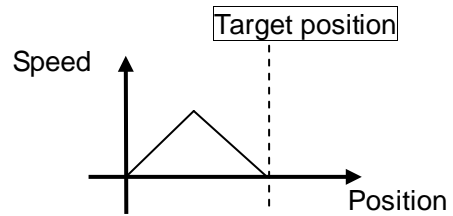

9.3. Pushing operation

When pushing is registered in [Step data] - [Operation], the pushing operation is executed.

Similar to the normal positioning operation, the actuator moves according to the settings of [Step data]-[Target Position] and controls with constant velocity when it reaches the pushing speed (6mm/s) during deceleration. (6mm/s)

When table recognizes that it reaches the workpiece, it performs the pushing operation with the pushing force ^{Note1)} specified in [Step data] - [Thrust setting value].

(1) Successful pushing operation

During the pushing operation, if the table reaches the value specified in [Step data] - [Target position], the INP output will be turned ON.

Note that once the table passes through the target position to push it against the workpiece, OUT0 (INP) output will be turned OFF.

- Pushing operation (Ex.)

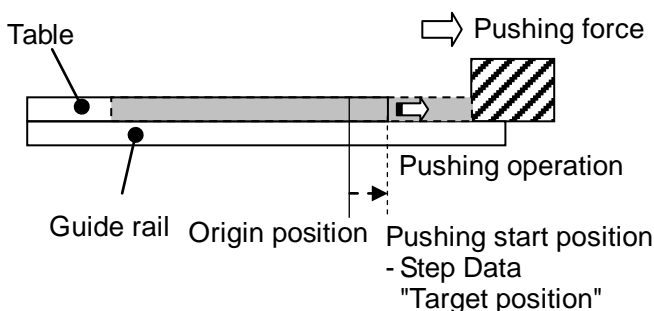

- Pushing operation (Cycle time entry) (ex.)

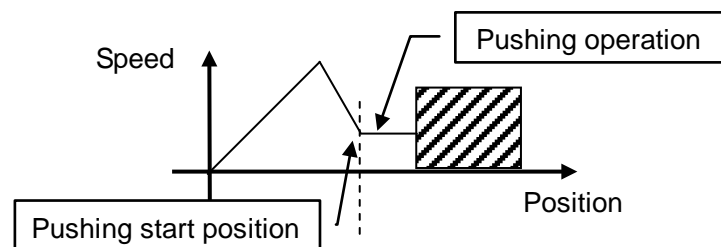

Note1) The pushing force varies depending on the operating environment, pushing direction and table position. The pushing force set to the step data is a guideline. The thrust setting value needs to be adjusted by the user as required.

Note2) When the maximum speed is 6 mm/s or less during the positioning operation phase, the speed during the uniform speed phase will be the same as the maximum speed during the positioning phase. Lowest limit speed limit is 1 mm/s.

If positioning operation is performed at a lower speed than 1 mm/s, the product does not perform a pushing operation.

(2) When the workpiece moves

(i) The workpiece moves in the pushing direction.

If the reaction force from the workpiece becomes smaller and the actuator moves with a force smaller than that specified in the [Step data] - [Thrust setting value] after the table reaches the workpiece, it continues pushing the workpiece to the position where the specified pushing force is generated.

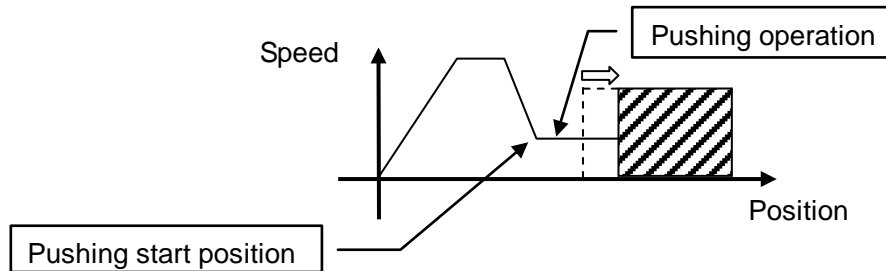

(ii) If the workpiece moves in the opposite direction of the pushing force (If it is returned due to a large reaction force from the workpiece) or if the reaction force from the workpiece becomes larger and the actuator is pushed back after the table reaches the workpiece, it continues to be pushed back until the reaction force and pushing force are balanced. (The actuator is pushed back in the pushing start direction.)

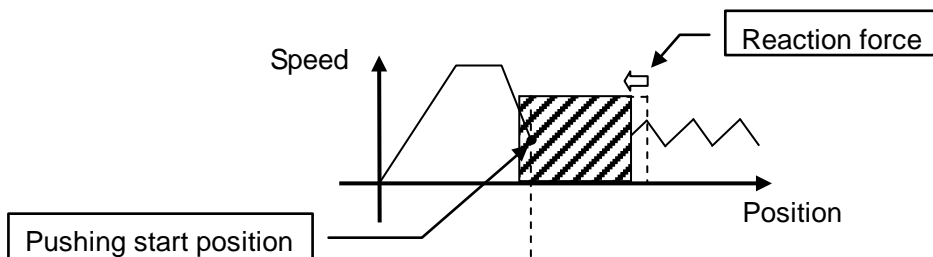

9.4 Jogging and Inching

Jogging and inching can be performed by pressing the “←” or “→” button, or clicking the “+” or “-“ button in Monitor mode and Test mode.

Operation methods

Jogging

The table moves in the direction that the button specifies as long as either the “←” or “→” button is being pressed. The table movement stops when the button is released.

When the table has reached the stroke end of the Card Motor, the table movement stops even if the button is being pressed.

The table moves at the speed in the “Speed” text box. The acceleration and deceleration are fixed, and cannot be changed.

The load mass setting for Step Data No.1 is also used for the return to origin operation.

Inching

When either the “+” button or “-“ button is pressed, the table moves for the preset travel distance. The position is held after completing the transfer motion has been completed.

When the table reaches the end of the Card Motor stroke range, it stops at the end of the stroke.

The table moves at the preset speed. The acceleration and deceleration are fixed, and cannot be changed.

The load mass setting for Step Data No.1 is also used for the return to origin operation.

9.5 Response time for the controller input signals

Response delay due to the controller input signal contains the following factors.

- (1) Controller input signal scan delay
- (2) Delay due to input signal analysis
- (3) Delay of command analysis

PLC processing delay and controller scan delay are generated. Ensure an interval of 2 msec or more between input signals, and maintain the signal state for at least 2 msec.

Initialize the input signal conditions according to response signal to the input signal.

9.6 Methods of interrupting operation

There are two methods of interrupting operation and stopping the actuator during positioning operation and pushing operation, as shown below.

The state after stopping is different, so use the method appropriate to the application.

- Stopped by DRIVE signal

If the DRIVE signal is turned OFF during operation, the stopped position is held after the actuator decelerates and stops,.

- Stopped by SVON signal

If the SVON signal is turned OFF during operation, the power supplied to the actuator is cut off and the table moves freely.

Warning

Consider possible unexpected movements of the Card Motor in the event of an emergency stop, alarm or power failure.

The table will not be held in place and may be moved by external forces if the power supply to the Card Motor is switched off due to an emergency stop or if the SVON signal is turned OFF, in the event of an alarm (when the temperature of the Card Motor exceeds 70°C) or at power failure. If the Card Motor is mounted vertically or at a slant, the table will drop.

Design the Card Motor application so that people and equipment will not be injured or damaged by unexpected table movements.

Warning

Do not hit the stroke ends with the work piece in operations other than return to origin position or at speeds higher than the specified pushing speed during pushing operation.

The Card Motor is equipped with a stopper to prevent the table from coming off and to take light impacts generated when returning to the origin position and when transferring work pieces within the specified limits. Excessive external force or impact may damage the Card Motor.

Install a separate external stopper if the operating conditions require.

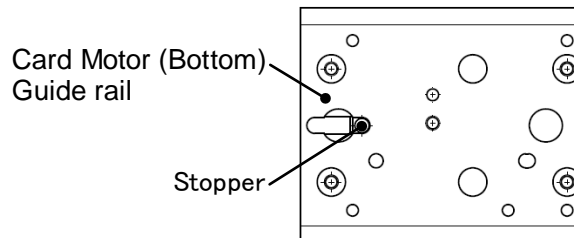

For pushing operations, set the target position at least 1 mm away from the position where the table or the pushing tool comes into contact with the work piece.

Otherwise, the table may hit the work piece at a speed exceeding the specified 6 mm/s pushing speed, which could damage the work piece and the Card Motor.

The Card Motor must not overheat.

The temperature rise of the Card Motor depends on the ambient conditions and usage. Take the following countermeasures if the temperature of the Card Motor rises so high that a temperature alarm is generated:

- Reduce the Thrust Setting Value.
- Reduce the duty ratio by increasing the cycle time.
- Improve the heat transfer properties of the mounting base and the surroundings.

(Refer to chapter **“14. alarm detection”** (P.66) for details.)

The thrust force generated by the Card Motor varies in relation to the “Thrust Setting Value”, depending on the table position, pushing direction and operating environment.

The “Thrust Setting Value” in the step data is a nominal value. Therefore, calibrate the “Thrust Setting Value” according to the application under real conditions.

If instructed to stop by the SVON signal, the BUSY signal will turn OFF and the OUT0 and OUT1 signals will be active or turn ON/OFF as follows.

If the AREA A and AREA B functions have been assigned to OUT0 and OUT1 then they will continue to turn ON/OFF depending on the AREA A and AREA B position range settings in relation to the table position.

If any other function has been assigned to OUT0 and OUT1 they will turn OFF.

10 Operation examples and procedures

10.1 Return to Origin example and procedure

After power has been supplied, the table is returned to origin from its initial position 5 mm away from the retracted end without load.

- Basic setting example

No.	Return to origin method
0	Origin at the retracted end

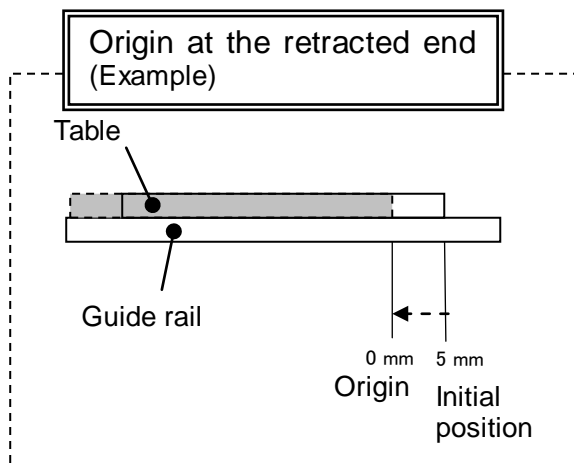
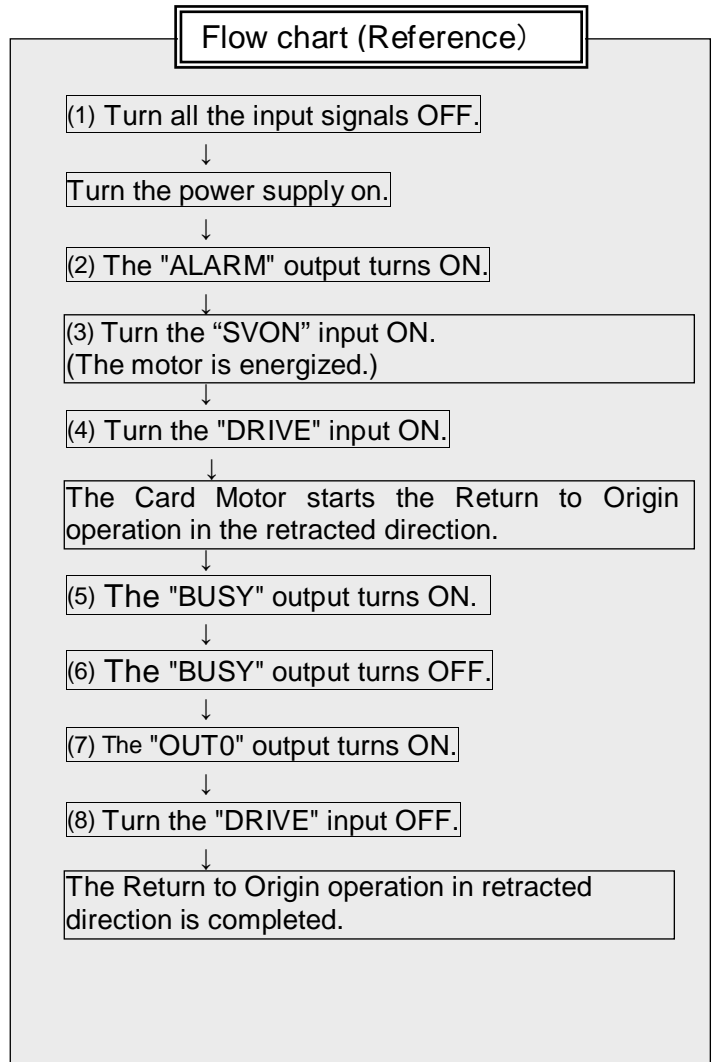
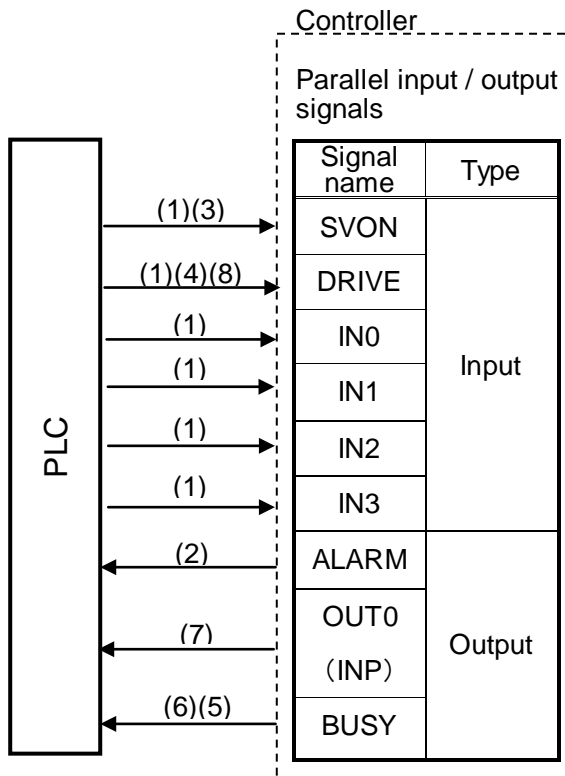

10.2 Positioning operation example and procedure

Step No. 1: The table is moved to absolute position 5 mm from the retracted end within 0.2 seconds without a load.

Step No. 2: The table is moved from absolute position 5 mm to absolute position 10 mm within 0.1 second.

- Step Data setting example

Step No.	Operation	Target position [mm]	Positioning time [s]	Load mass [g]
0	-	-	-	-
1	Positioning	5.00	0.20	0
2	Positioning	10.00	0.10	0

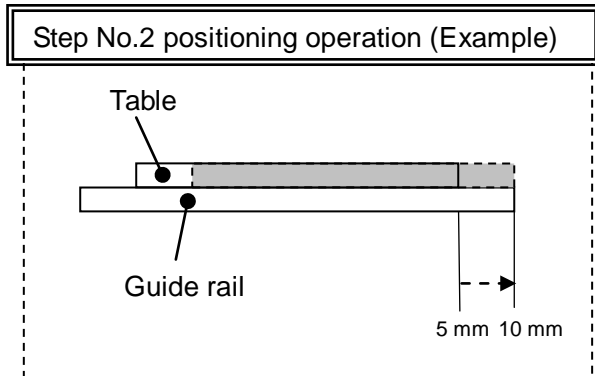
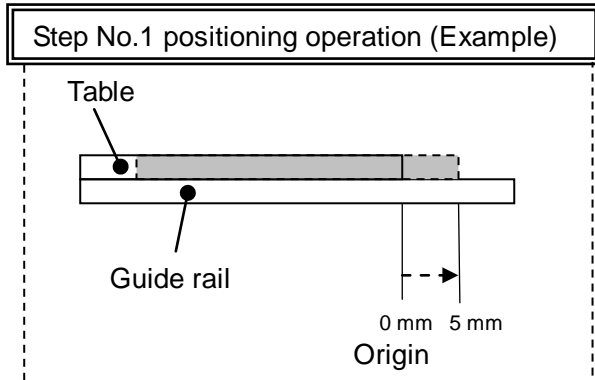
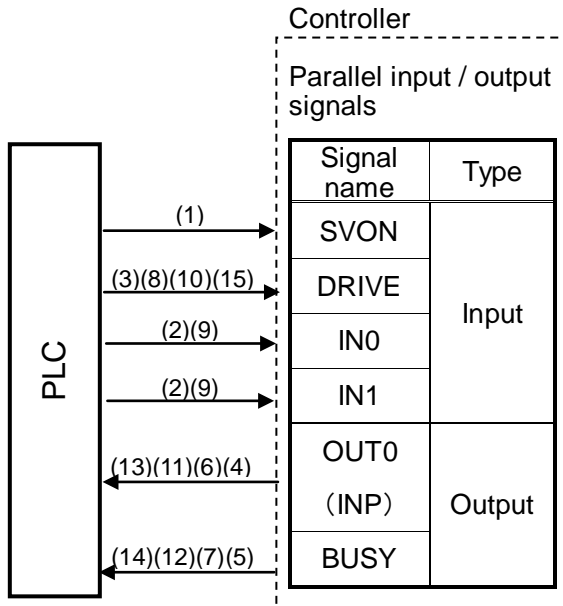

Flow chart (Reference)

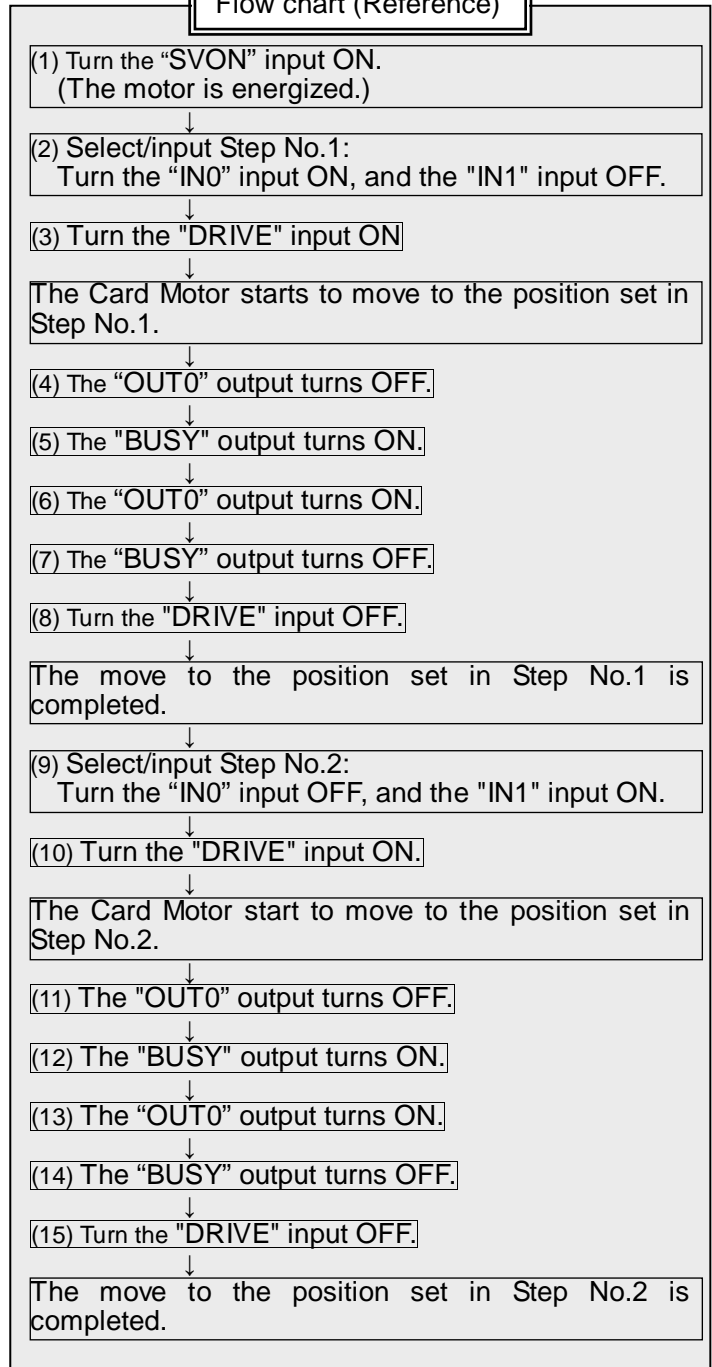

Note) It is required that the Return to Origin is performed before Step Data can be executed.

10.3. Pushing operation example and procedure

Step No. 1: The table is moved to absolute position 9 mm from the retracted end within 0.5 seconds with a load of 500 g.

From the position where the speed is decelerated to 6 mm/s, the table comes into contact with the workpiece at that speed and pushes it with a thrust setting value of 2 or less.

Step No. 2: From the position where the table pushes the workpiece, the table moves to absolute position 5 mm from the origin position within 0.1 second.

- Step Data setting example

Step No.	Operation	Target position [mm]	Positioning time [s]	Thrust setting value	Load mass [g]
0	-	-	-	-	-
1	Pushing	9.00	0.50	2	500
2	Positioning	5.00	0.10	-	500

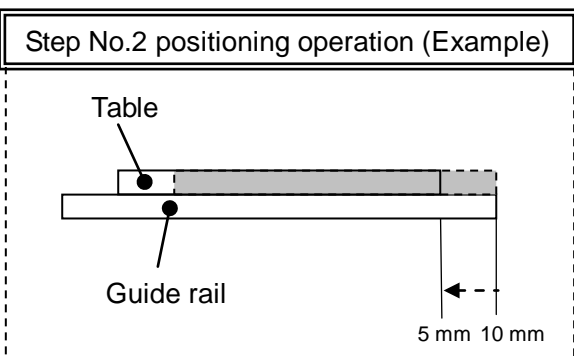
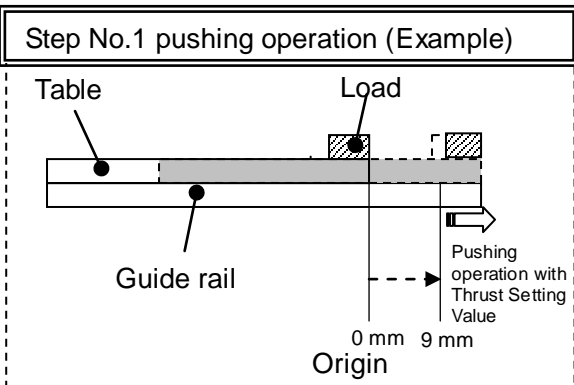
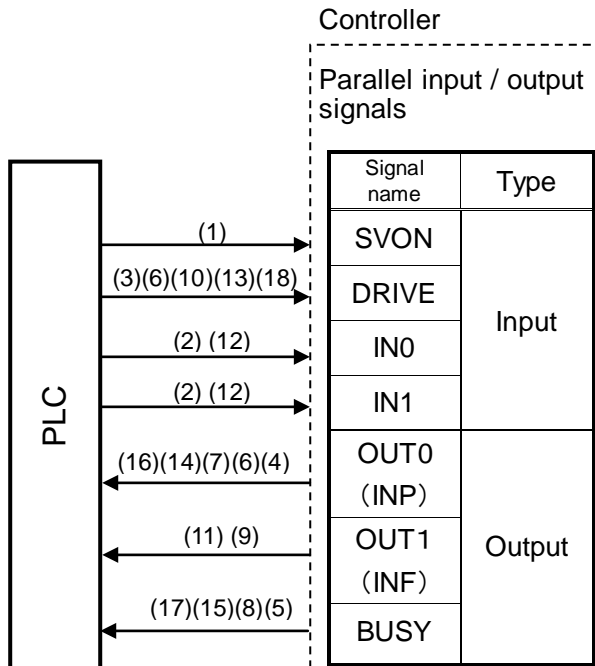

Flow chart (Reference)

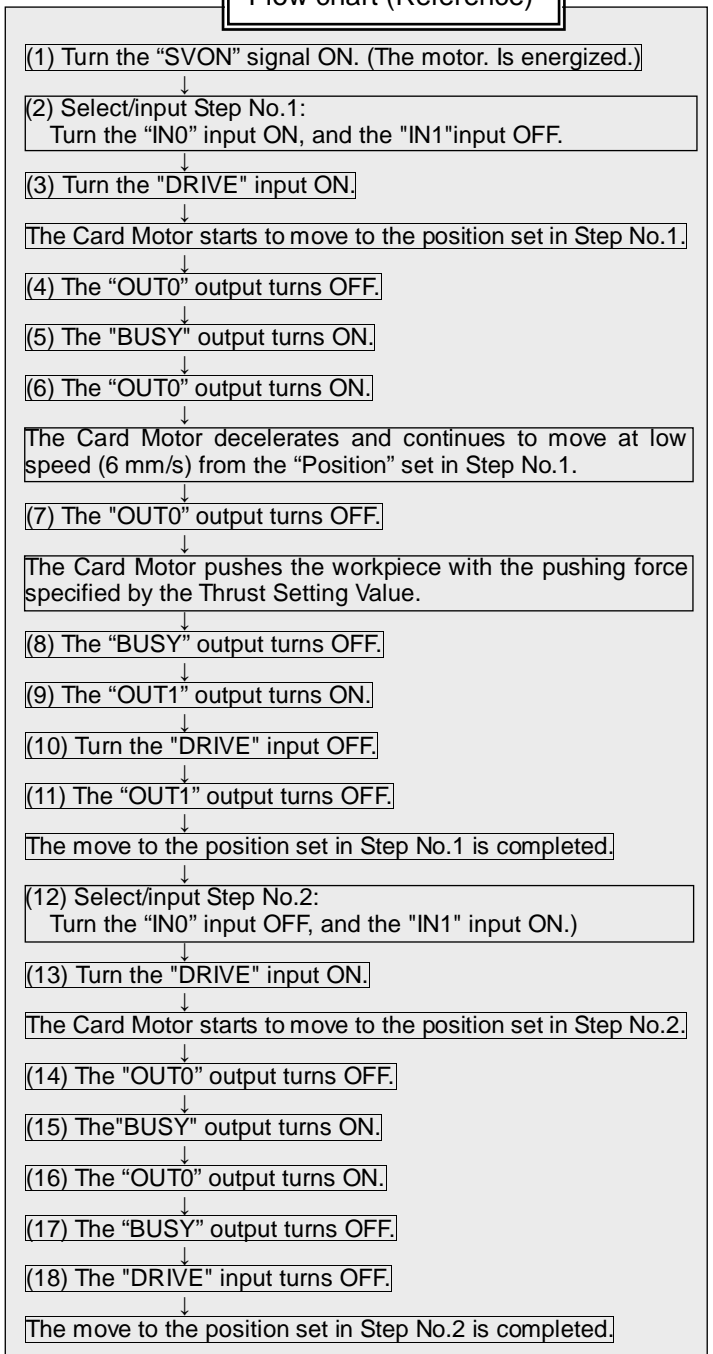

Note) It is required that the Return to Origin is performed before Step Data can be executed.

11. Operation instruction

11.1 Overview of the operation instructions

The Card Motor is operated by selecting step data preset in the controller using the digital I/O signals. Switch to Monitor Mode or Terminate the Controller Setting Software to use parallel I/O signals for controlling the Card Motor.

To avoid accidents any active parallel I/O signals are ignored when the Controller Setting Software is started (except when it is in Monitor Mode) or when the power is turned on to the controller.

See next chapter for details of the parallel I/O signal timing and control procedures.

11.2 Parallel I/O operation procedures

Refer to the following "Procedures" and "Timing charts" for details of the Return to Origin and the operation mode procedures and signal timing.

(1) Power on and Return to Origin position

- Procedure -

- (i) Switch the power supply on.
- ↓
- (ii) The "ALARM" output turns ON.
- ↓
- (iii) Turn the "SVON" input ON.
- ↓
- (iv) Assign Step Data No. for Origin:
Turn OFF all Step Data No. inputs (IN0 to IN3).
- ↓
- (v) Turn the "DRIVE" input ON.
→ The Step Data No. inputs (IN0 to IN3) are read by the controller.
- ↓
- (vi) The "BUSY" output turns ON.
(The Return to Origin operation starts.)
- ↓
- (vii) When the "OUT0" (INP) output turns ON and the "BUSY" output turns OFF, the Return to Origin position operation has been completed.

- Timing chart -

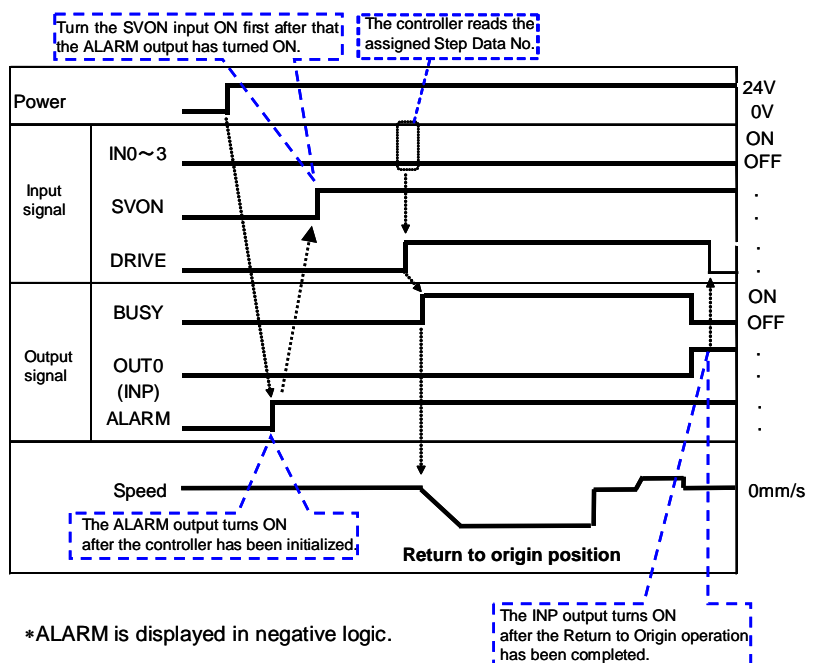

⚠ Caution

The controller is being initialized after the power supply has been turned on until the ALARM output has turned ON. Ensure that no operation command input signals are activated before the ALARM output has turned ON.

(2) Positioning operation

- Procedure -

- (i) Assign the Step Data No. to be performed:
Select the corresponding combination of high and low status for the Step Data No. inputs (IN0 to IN3).
- ↓
- (ii) Turn the "DRIVE" input ON.
--> The Step Data No. inputs (IN0 to IN3) are read by the controller.
- ↓
- (iii) The "BUSY" output turns ON.
(The positioning movement starts.)
- ↓
- (iv) The positioning operation is completed when the "OUT0" (INP) output has turned ON and the "BUSY" output has turned OFF.

-Timing chart-

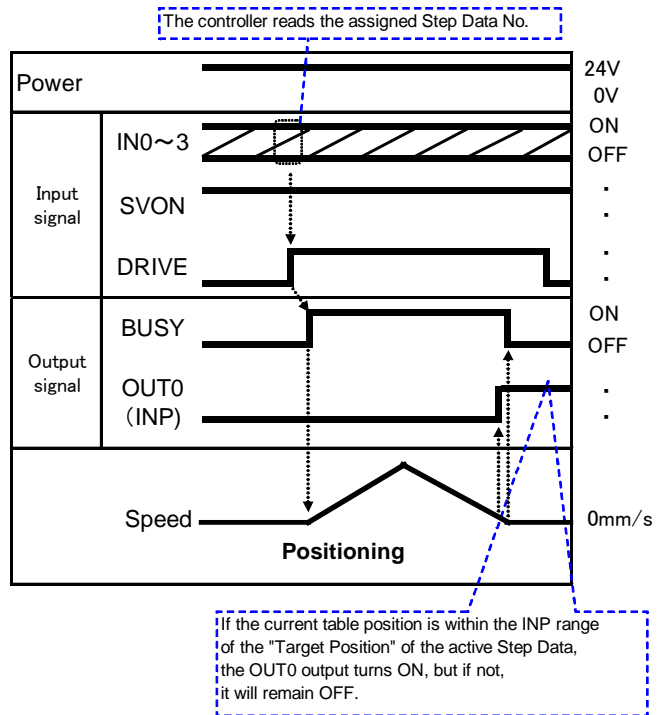

(3) Pushing operation

- Procedure -

- (i) Assign the Step Data No. to be performed:
Select the corresponding combination of high and low status for the Step Data No. inputs (IN0 to IN3).
- ↓
- (ii) Turn the "DRIVE" input ON.
-->The Step Data No. inputs (IN0 to IN3) are read by the controller.
- ↓
- (iii) The "BUSY" output turns ON and remains ON as long as the table is moving.
- ↓
- (iv) The "OUT0 (INP)" is ON as long as the table position is within the "INP" range of the "Target Position".
- ↓
- (v) The "OUT1 (INF)" turns ON when the generated force exceeds the set "INF" "Threshold Force Value".
(Thrust based on the step data "Thrust Setting Value" is generated)
- ↓
- (vi) The pushing operation is completed by turning OFF the "DRIVE" input and when the BUSY output has turned OFF.

-Timing chart-

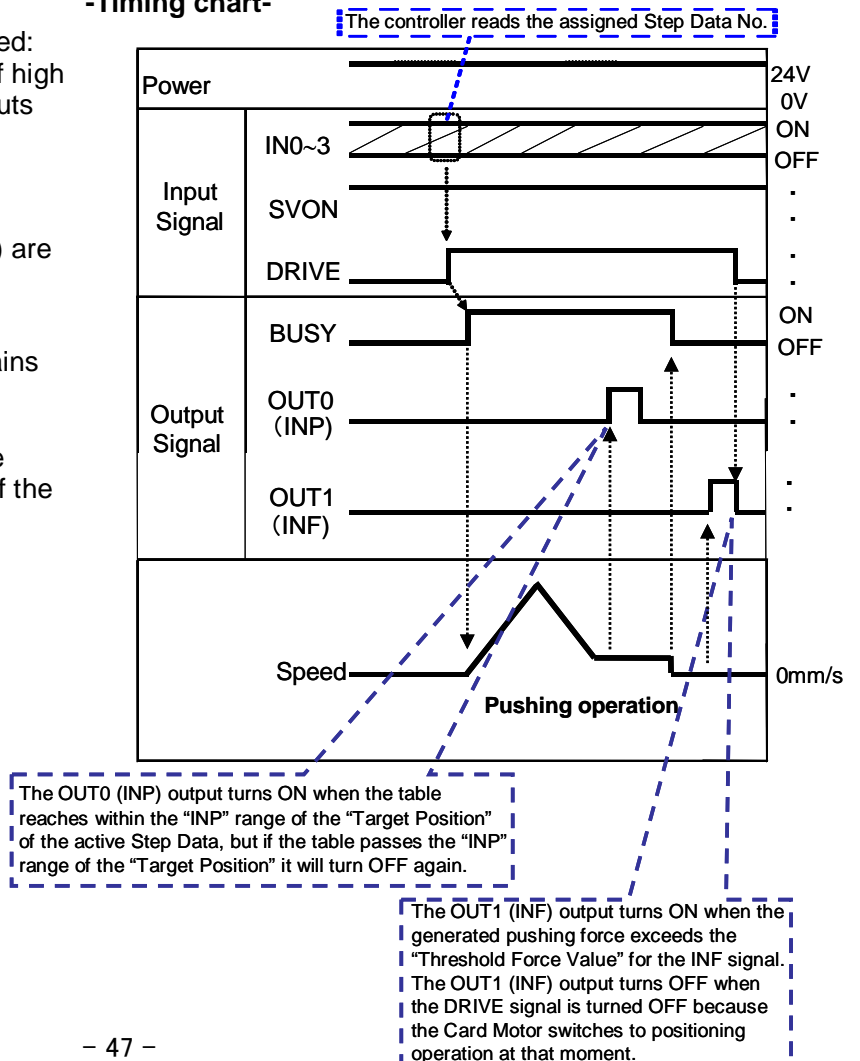

(4) Alarm reset

- Procedure -

(i) An alarm has been generated.
(The "ALARM" output is OFF.)



(ii) Turn the "SVON" input OFF.



(iii) Turn the "SVON" input ON.



(iv) The "ALARM" output is turned ON.

-Timing chart-

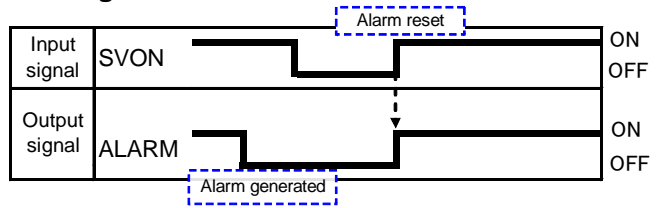

*ALARM is displayed in negative logic.

Caution

Use a 2 msec interval or more between input signals, and maintain the signal state for at least 2 msec.

Refer to chapter "9.5 Response time for the controller input signals" on page 41 for details.

12. Card Motor Controller Setting Software

12.1 Setup of the Controller Setting Software

(1) Installation of the software

Copy the “LATC-W1.EXE” execution file to the desktop of your computer.

(2) Start-up

i. Double-click the icon shown below, and the “Please select COM port No.” dialog box will appear.



Caution

Please confirm that the controller is connected with the Card Motor and each cable.

(ii) Select the COM port number the controller is connected to and click [OK].

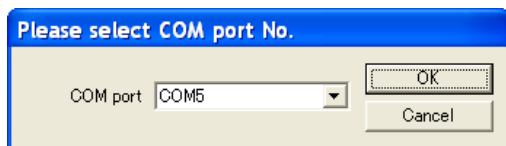

["Please select COM port No." dialog box]

After one successful connection, the same COM port will be selected automatically. (The “Please select COM port No.” dialog box will not appear again.)

When the controller is connected to the different COM port, or when the connection fails, for example if the COM port cannot be opened, the “Please select COM port No.” dialog box will appear again.

If the COM port cannot be opened, the error message shown below will appear and the software starts up in offline mode.

Only [Step data setup], [Save] and [Open] can be carried out in offline mode.

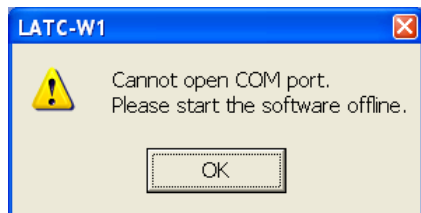

If the controller and the PC cannot be connected if the COM port can be opened but the controller power supply is OFF, the error message below will appear and the reading of the [Basic parameter setup] settings will be interrupted.

In such a case, confirm that power is supplied to the controller and that the controller setting cables are connected.

If the connection is established, the reading of the [Basic parameter setup] settings will be restarted automatically.

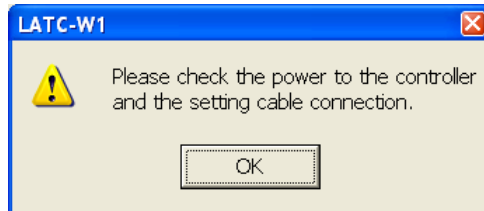

(iii) The main window will appear.

The connected COM port number will be displayed after the title.

Select a tab according to the application situation.

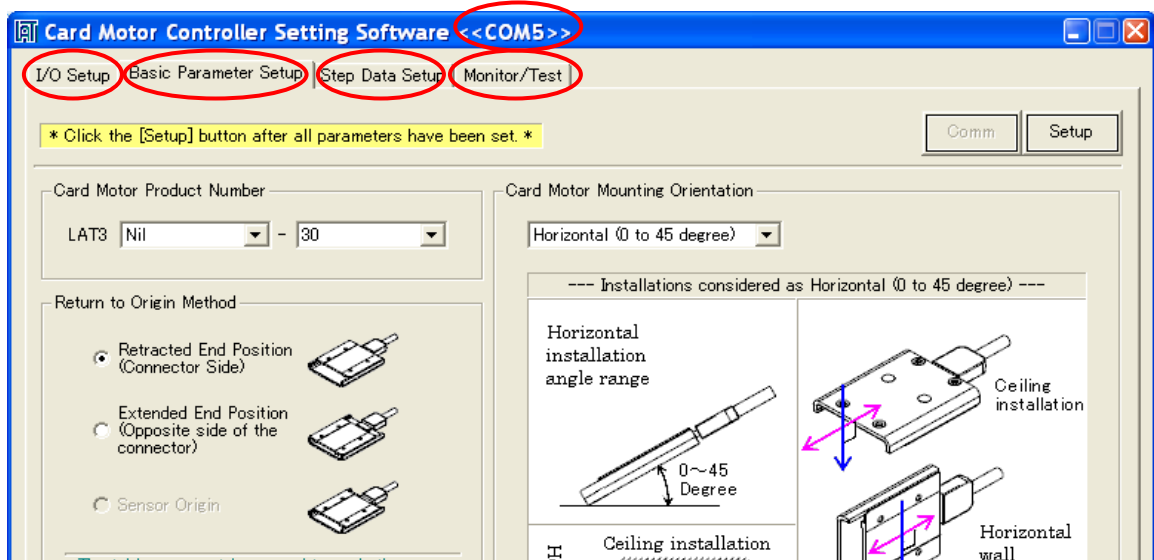

[Main window]

Caution

Do not turn off the power supply to the controller and do not connect or disconnect the controller setting cable whilst the Controller Setting Software is running.

Turn off the power supply to the controller when disconnecting the controller setting cable.

If the power supply to the controller is turned off whilst the Controller Setting Software is running, turn on the power supply immediately to recover it.

If the cable comes off, restart the Controller Setting Software after reconnecting the cable.

12.2 Basic Parameter Setup window

Register the basic parameter setup of the actuator (Card Motor).

If the controller is connected normally, the data registered in the controller will be displayed immediately after the software starts up.

If [Setup] is executed after arbitrary item values are changed, the setting values are saved to the controller connected to the PC.

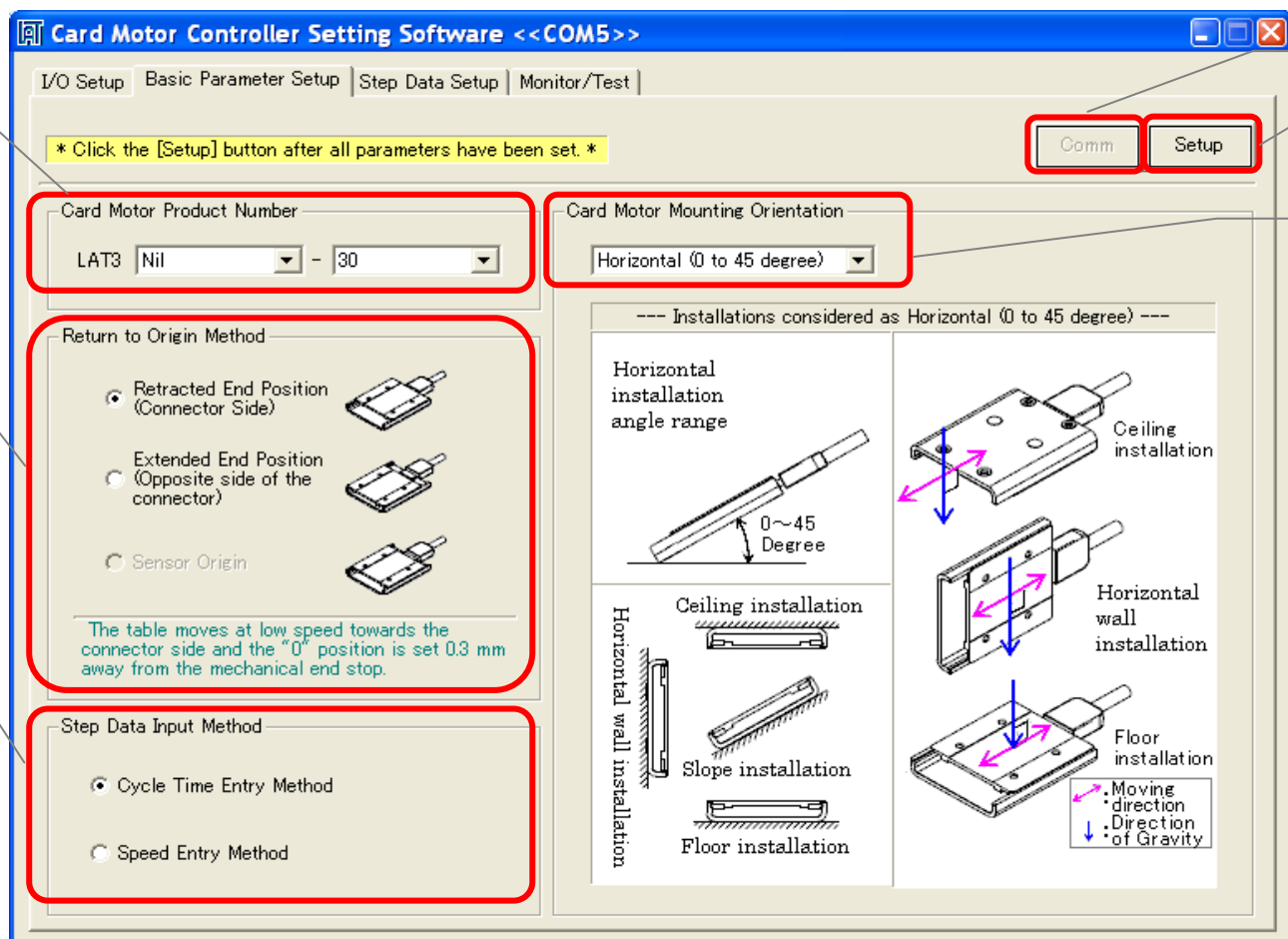

[Basic Parameter Setup window]

(i) Card Motor Product No.

Select the product No. of the Card Motor connected to the controller.

(ii) Method to Return to Origin Position

Select the required method of returning to origin position. (Sensor origin can only be selected for LAT3E-*)

(iii) Step data Input Version

Cycle Time Entry Method: Specify [Target position], [Positioning time] and [Load mass] to operate the Card Motor.

Speed Entry Method: Specify [Target position], [Speed], [Acceleration], [Deceleration] and [Load mass] to operate the Card Motor.

(iv) Card Motor Mounting Orientation

Select horizontal or vertical Card Motor orientation.

(v) Communication

If the communication is disconnected whilst the Controller Setting Software is starting, the communication can be restored by clicking the "Communication" button.

However, communication cannot be restored unless the cause of the communication disconnection is solved.

(vi) Setup

The set Basic Parameters are sent to the controller that is connected to the PC.

! Caution

To finalize the settings, execute the controller reset operation as shown below before operating the Card Motor.

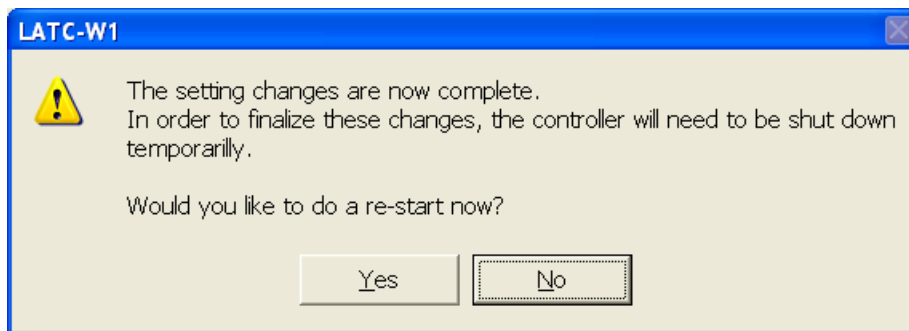

[Controller reset confirmation message]

! Caution

If the communication is discontinued in the middle of the transmission of the Basic Parameters, the data may not be written correctly.

If this happens, it appears as if the data has been written correctly when this software is restarted and the set data is read from the controller, but the data has actually not been saved to the controller.

Supply power to the controller again and set and send the data again.

12.3. Step Data Setup window

The actuator (Card Motor) operation can be registered up to 15 operations.

When [Upload]  is executed, the applicable data registered in the controller is displayed.

If [Download]  is executed after item values are changed, the setting values are sent to the controller connected to the PC.

ii. Command button

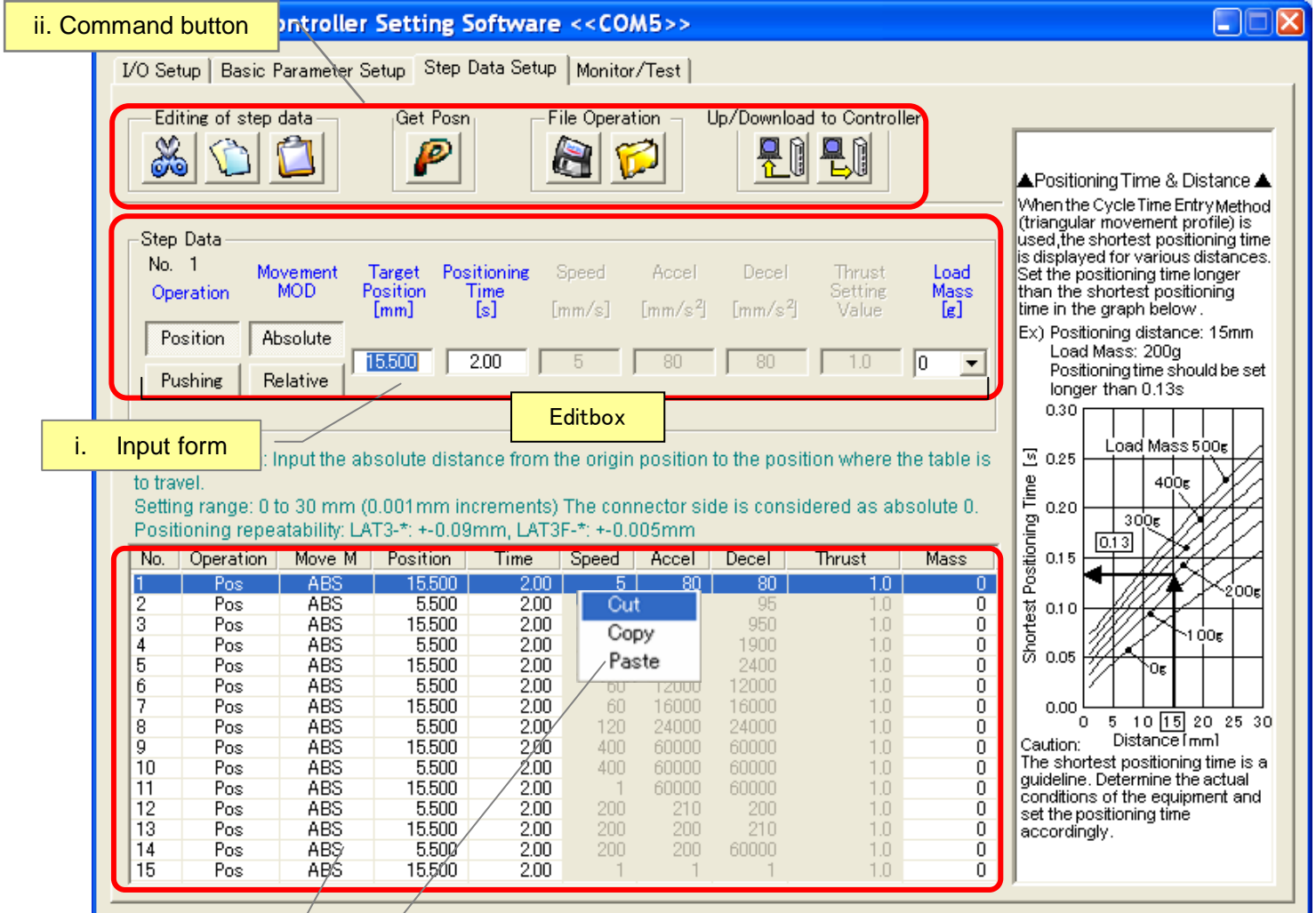

i. Input form : Input the absolute distance from the origin position to the position where the table is to travel.
Setting range: 0 to 30 mm (0.001 mm increments) The connector side is considered as absolute 0.
Positioning repeatability: LAT3-*: +0.09mm, LAT3F-*: +0.005mm

No.	Operation	Move M	Position	Time	Speed	Accel	Decel	Thrust	Mass
1	Pos	ABS	15.500	2.00	5	80	80	1.0	0
2	Pos	ABS	5.500	2.00			95	1.0	0
3	Pos	ABS	15.500	2.00			950	1.0	0
4	Pos	ABS	5.500	2.00			1900	1.0	0
5	Pos	ABS	15.500	2.00			2400	1.0	0
6	Pos	ABS	5.500	2.00	60	12000	12000	1.0	0
7	Pos	ABS	15.500	2.00	60	16000	16000	1.0	0
8	Pos	ABS	5.500	2.00	120	24000	24000	1.0	0
9	Pos	ABS	15.500	2.00	400	60000	60000	1.0	0
10	Pos	ABS	5.500	2.00	400	60000	60000	1.0	0
11	Pos	ABS	15.500	2.00	1	60000	60000	1.0	0
12	Pos	ABS	5.500	2.00	200	210	200	1.0	0
13	Pos	ABS	15.500	2.00	200	200	210	1.0	0
14	Pos	ABS	5.500	2.00	200	200	60000	1.0	0
15	Pos	ABS	15.500	2.00	1	1	1	1.0	0

▲Positioning Time & Distance▲
When the Cycle Time Entry Method (triangular movement profile) is used, the shortest positioning time is displayed for various distances. Set the positioning time longer than the shortest positioning time in the graph below.
Ex) Positioning distance: 15mm
Load Mass: 200g
Positioning time should be set longer than 0.13s

Shortest Positioning Time [s]

Distance [mm]

Caution:
The shortest positioning time is a guideline. Determine the actual conditions of the equipment and set the positioning time accordingly.

iii. Pop-up menu

[Step Data Setup screen]

(i) Input form

When a line on the list view is clicked, the content can be edited in (i) input form.

It is necessary to select other step data lines to reflect the input content on the list view and there are three ways.

- Click other lines on the list view.
- Press the Enter key on the input form.
- Press the cursor keys (\uparrow/\downarrow) on the edit box of the input form.

The download button (ii)  needs to be clicked to send the changed content to the controller. Data in the Input form can be cancelled by pressing the Esc key.

Operation

Select [Position] or [Pushing] operation. (The selected operation mode is greyed.)

When [Position] is selected, it is not possible to enter a [Thrust Setting Value].

When [Pushing] is selected, it is possible to enter a [Thrust setting value].

– Movement modes

Click “Absolute” for absolute positioning and “Relative” for relative positioning. Absolute: The absolute distance from the origin position.

ABS (Absolute positioning)

The position is determined in relation to the "**Origin position when the table is retracted**".

REL (Relative positioning)

The position is determined in relation to the "**current table position**".

– Target position

Enter the target position corresponding to the operation mode.

It is possible to set 0 mm to 10 mm, 0 mm to 20 mm, 0 mm to 30 mm depending on the stroke of the Card Motor in 0.001mm increments.

Negative values can be entered only in relative movement mode. The table moves towards the retracted direction with negative values.

Depending on the current position of the table, the target position for a relative position can be out of the operation range of the Card Motor.

In such a case, the target position is limited to the stroke end of the Card Motor, and the INP signal and INFP signals will not be output after the table movement has been completed.

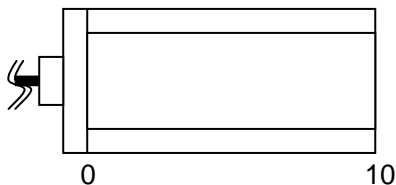

-When the stroke is 10 mm-

The extended end position becomes 10 and retracted end position becomes 0.

– Positioning time

Set the time required to reach [Target position]. 0 to 60 seconds can be input.

It does not perform the positioning control when it is set to “0”.

(It is possible to enter the positioning time when selecting [Cycle time entry method] in [Step data entry method] with the unit of 0.001second.)

– Speed

Enter the speed required to reach [Target position]. 1 to 400 mm/s can be input.

It is possible to enter the speed when [Speed entry method] is selected in [Step data input version] with the unit of 1 mm/s.

– Accel

Enter the acceleration required to reach [Speed]. 1 to 60,000 mm/s² can be input.

It is possible to enter the acceleration when [Speed entry method] is selected in [Step data input version] with the unit of 1 mm/s².

- Decel

Enter the deceleration from [Speed] to stop. 1 to 60,000 mm/s² can be input.

It is possible to enter the deceleration when [Speed entry method] is selected in [Step data input version] with the unit of 1 mm/s².

- Thrust setting value

Set the maximum force for the pushing control. It is possible to set 1 to 5, 1 to 4.8, 1 to 3.9 with the stroke of the Card Motor.

It is possible to enter the thrust setting value when [Pushing] is selected in [Operation] with the unit of 0.1.

*The thrust setting value should be smaller than the allowable setting pushing force of the Card Motor used.

Refer to the operation manual for the LAT3 series (Card Motor) for the allowable setting pushing force.

- Load mass

Set the load mass of the workpiece mounted on the motor. It is possible to select the load mass from 0 to 500 g in the unit of 50g increments.

*The selected load mass will be a guideline, so be sure to check the operation sufficiently before setting and using the Card Motor and controller.

* The controller uses the load mass value set for Step Data No.1 for returning to origin and for jogging. Confirm that the load mass has been set for Step Data No.1 when performing return to origin and/or jogging.

 **Caution**

Set the "load mass" value for the Step Data as close as possible to the load mass that is mounted onto the table. Avoid changing the load mass that is mounted onto the table whilst the table is moving.

The table may vibrate if there is a large difference between the "load mass" set in the Step Data and the load mass mounted on the table.

(ii) Command button



Cut

Cut the selected step data.

* It is possible to cut when right-clicking the list view and selecting [Cut] from the pop-up menu.



Copy

Copy the selected step data.

* It is possible to copy when right-clicking the list view and selecting [Copy] from the pop-up menu.



Paste

The copied or cut data is pasted to the selected step data.

* It is possible to paste when right-clicking the list view and selecting [Paste] from the pop-up menu.



Reading of the current position

The current position of the Card Motor table is read. The read value will be set as the "Target Position".

* This is valid only for the Step Data whose operation mode is set to absolute positioning.
Step Data whose operation mode is set to relative positioning will not be read.

Caution

Complete the Returning to Origin operation is completed before reading the current position.
After downloading (writing) the step data to the controller, perform return to origin again before reading the current position.



Save

Save the step data in the file.



Open

Read the step data from the file.



Upload

Display the data from the controller within the setting software (PC).



Download

Rewrite the controller from the setting software with the data displayed within the setting software (PC).

Caution

If the process is interrupted whilst uploading data from the controller, the data may not appear correctly in the Controller Setting Software.

In this case, upload the data again.

If the process is interrupted whilst downloading data from the Controller Setting Software, the data may not be written correctly to the controller.

If this happens, it appears as if the data has been written correctly when this software is restarted and the set data is read from the controller, but the data has actually not been saved to the controller.

Supply power to the controller again and set and send the data again.

(iii) Pop-up menu

When right-clicking the list view, the pop-up menu is displayed.



12.4 Monitor/Test window

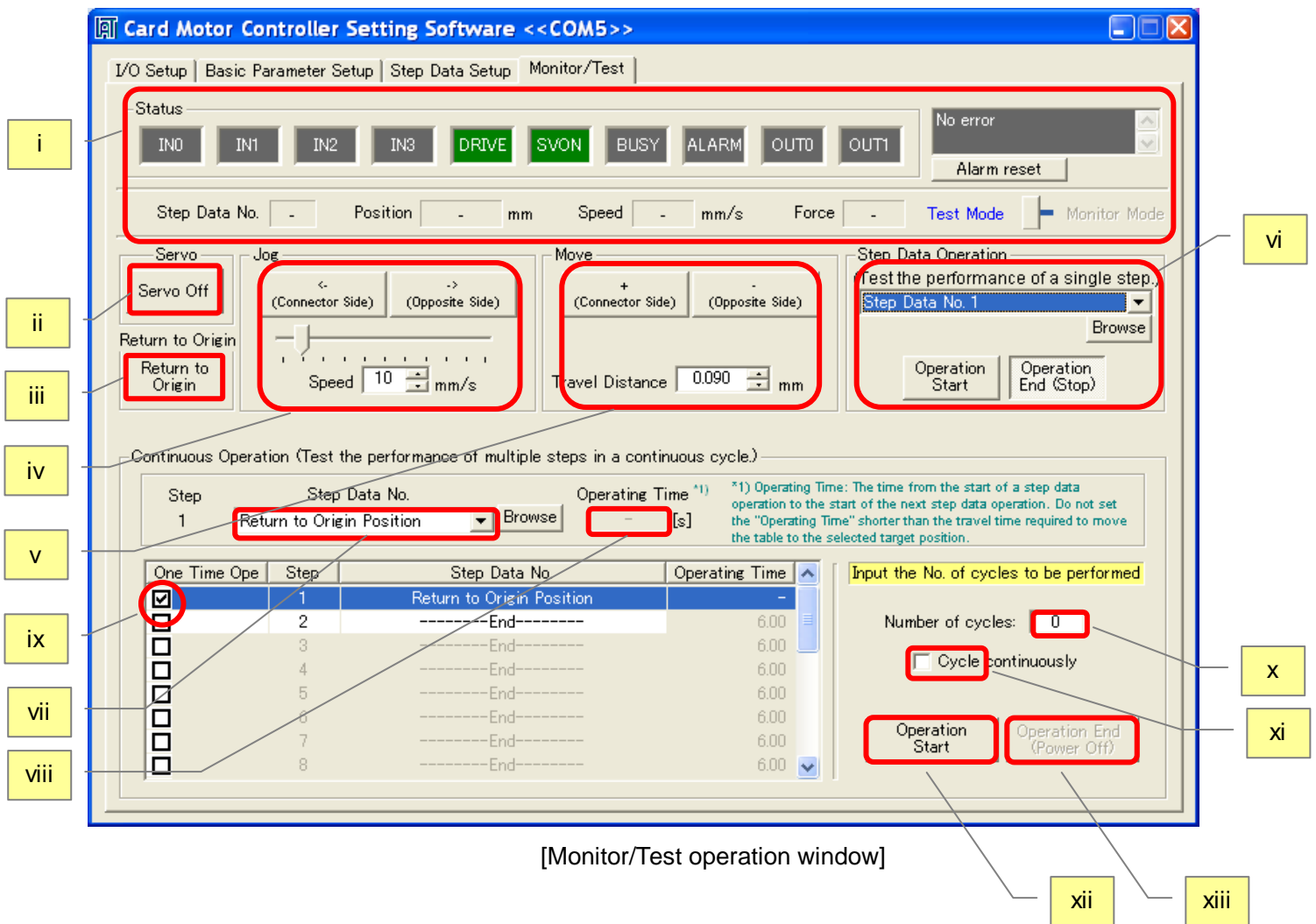

(i) Status display

Displays the current parallel I/O status.

The latest alarm status can be checked from the alarm window in the upper right corner.

The alarm history can be cleared by pressing the history reset button below it.

The current Step Data No., position, speed and pushing force values are shown in the lower row. (after returning to origin).

All values shown in this display are reference values only.

By switching to Monitor mode it is possible to operate the Card Motor with external I/O signals, and the operating status can be monitored here. (In Monitor mode, it is not possible to command operation using the Controller Setting Software.)

Note that every control is canceled when switching between the Monitor mode and Test mode.

(ii) Servo Off / Servo On

When this button is clicked, a command to energize the Card Motor is sent to the controller.

When this button is clicked once again, a command to de-energize the Card Motor is sent to the controller.

(iii) Return to Origin / During Return to Origin

When this button is clicked, a return to origin command is sent to the controller immediately.

After the return origin operation has been completed, this button is cancelled automatically.

Select the method for the return to origin operation from the [Return to origin method] menu in the "Basic Parameter Setup" window.

(iv) Jogging

Whilst this button is being pressed, the Card Motor table moves at the speed set in the "Speed" list box. When this button is released, the Card Motor table stops the operation. The right button is for the + direction (towards the extended end), and the left button is for the - direction (towards the retracted end).

(v) Inching

By clicking this button the Card Motor table moves the distance set in the "Move Distance" list box. ("Speed" is the same that is set for Jogging.) The table moves in the + direction (towards the extended end) when the + button is clicked, and in the - direction (towards the retracted end) when the - button is clicked.

(vi) Step Data settings

The signal is sent to the controller by selecting the step data and switching the [Operation Start] and [Operation End (Stop)] buttons.

* When the motor test operation is temporarily stopped, click the [Operation End (Stop)] button.

When the test operation is discontinued, click the [Operation End (Stop)] button and then [Servo Off] button to stop energizing.

It is possible to select the step data as referring to each parameter saved in the controller with the [Browse] button.

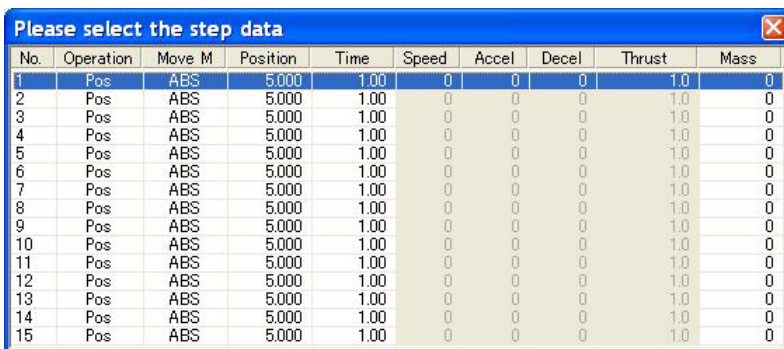

No.	Operation	Move M	Position	Time	Speed	Accel	Decel	Thrust	Mass
1	Pos	ABS	5,000	1.00	0	0	0	1.0	0
2	Pos	ABS	5,000	1.00	0	0	0	1.0	0
3	Pos	ABS	5,000	1.00	0	0	0	1.0	0
4	Pos	ABS	5,000	1.00	0	0	0	1.0	0
5	Pos	ABS	5,000	1.00	0	0	0	1.0	0
6	Pos	ABS	5,000	1.00	0	0	0	1.0	0
7	Pos	ABS	5,000	1.00	0	0	0	1.0	0
8	Pos	ABS	5,000	1.00	0	0	0	1.0	0
9	Pos	ABS	5,000	1.00	0	0	0	1.0	0
10	Pos	ABS	5,000	1.00	0	0	0	1.0	0
11	Pos	ABS	5,000	1.00	0	0	0	1.0	0
12	Pos	ABS	5,000	1.00	0	0	0	1.0	0
13	Pos	ABS	5,000	1.00	0	0	0	1.0	0
14	Pos	ABS	5,000	1.00	0	0	0	1.0	0
15	Pos	ABS	5,000	1.00	0	0	0	1.0	0

[Step data reference window]

Double click the line of step data to be executed when the pop-up screen is displayed.

(When using the [Browse] button, it is necessary to perform [Upload] or [Download] stated in

12.3 Step data setup screen (P.52) to upload or download the step data in the controller.)



[Controller reading message]

Caution

When changing the step data to be executed, press the [Operation End (Stop)] button.

(vii) Step data No.

Select the step data No. to be executed (return to origin position, step data and end) from the pulldown menu. (Same as (vi), it is possible to select it from the [Browse] button.)

When [End] is selected, the step data No. input values after that become invalid.

(viii) Operating Time

Set the time how long the controller takes until the step data operation completes. (unit : 0.1 second)

After the Card Motor controller operation is specified, the next data is executed when there is response from the controller that the execution command has been received after the set time had passed.

When performing the return to origin position, the operation time should be set between 6.0 to 10.0 seconds.

When executing the Step Data, enter an operating time value that is longer than the time required for the Step Data operation to be completed and equals to or is shorter than 60.0 seconds.

(ix) One Time Operation

When this item is checked, only the initial cycle of continuous execution is executed and second and later will be skipped.

(x) Repeat Count

Enter the continuous operation count of a series of step data selected in the continuous operation with a positive number not more than 100.

When executing the operation only one time, the repeat count should be "0".

(xi) Continuous

When this item is checked, a series of step data selected in the continuous operation is repeated until [Operation end (Power Off)] is pressed.

In this operation, the input value of [Repeat Count] becomes invalid.

(xii) Operation start

The operation will start.

(xiii) Operation end (Power Off)

The operation will be stopped.

! Caution

When an alarm is generated

If the LED[ALM] on the front surface of the controller turns red or flashes, the alarm goes off.

Perform SVON reset and cancel the alarm after measures and revisions are made.

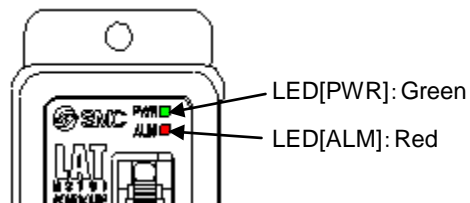

SVON reset

Click [Servo On] first and then click [Servo Off].

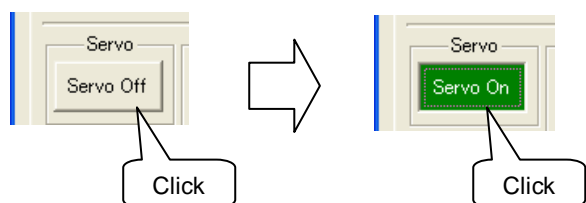

Note) It is possible to check the type of the alarm by a combination of lighting and flashing of ALM and PWR LEDs. Refer to **“14. Alarm Detection Details P.66”** for detailed content of alarm.

12.5 I/O Setup window

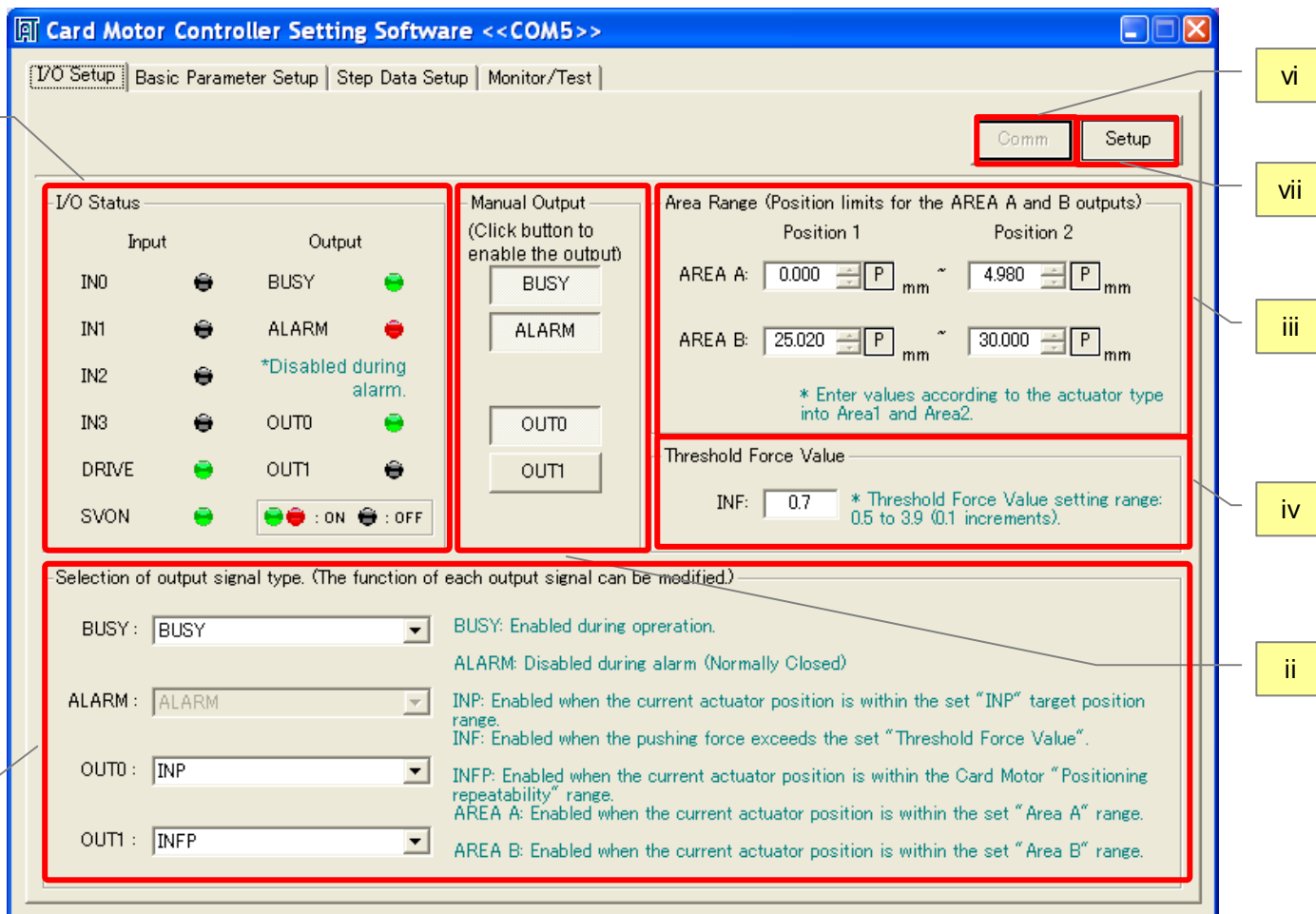

【I/O Setup window】

(i) I/O Status

Displays the current input and output signal status.

(ii) Manual Output

Each output signal can be turned ON and OFF manually regardless their current status to check the connection.

Normally the ALARM output is OFF when an alarm has been generated, but the ALARM output can be turned ON manually by pressing the ALARM button.

Manual outputs are cancelled when another window is selected.

(iii) Area Range

Enter the position ranges for the AREA output signals.

Separate position ranges can be set for up to two outputs: "AREA A" and "AREA B".

The resolution for the "Position 1" and "Position 2" settings varies depending on the Card Motor models.

Card Motor model	Resolution
LAT3-*	0.03 [mm]
LAT3F-*	0.005 [mm]

The position ranges should be set as follows: Position 1 ≤ Position 2.

The current table position of the Card Motor can be read by pressing the  button after return to origin has been completed.

(iv) Threshold Force Value

This determines the condition for when the INF signal is activated.

The INF signal turns ON when the pushing force generated by the Card Motor exceeds the set value.

The INF output will not be activated if the "Threshold Force Value" is larger than the "Thrust Setting Value" in a Step Data, because the "Threshold Force Value" can be set independently from the "Thrust Setting Value" in the Step Data.

(v) Selection of output signal function

The function of the parallel output signals can be modified.

It is possible to use the same signal function for more than one output terminal, and another signal function can also be assigned to the BUSY output terminal.

(vi) Communication

If the communication is interrupted whilst the Controller Setting Software is running, the communication can be restored by clicking the "Comm" button.

However, the communication cannot be restored unless the cause of the communication disconnection is solved.

(vii) Setup

The modified values are sent to the controller connected to the PC.

However, the manual I/O Status will not be saved.

12.6 Closing the software

Close the software by clicking the [Close] button on the right top of the window or from the title menu (by clicking the icon on the left top).

Caution

Turn the power supply to the controller OFF and ON again before operating the controller with the parallel I/O signals after the Controller Setting Software has been terminated.

Refer to chapter “**11.1 Overview of the operation instructions**” on page 46 for details.

13. Option

13.1. I/O cable

(1) How to Order I/O cable

L A T H 2 - □

Cable length [L]

1	1m
3	3m
5	5m

(2) Parallel I/O cable plug terminal

Terminal number	Function
A1	COM
A2	IN 0
A3	IN 1
A4	IN 2
A5	IN 3
A6	DRIVE
A7	SVON
A8	NC
A9	NC
A10	NC

Terminal number	Function
B1	DC2(+)
B2	DC2(-)
B3	BUSY
B4	ALARM
B5	OUT0
B6	OUT1
B7	NC
B8	NC
B9	NC
B10	NC

(3) Outer dimensions of I/O cable

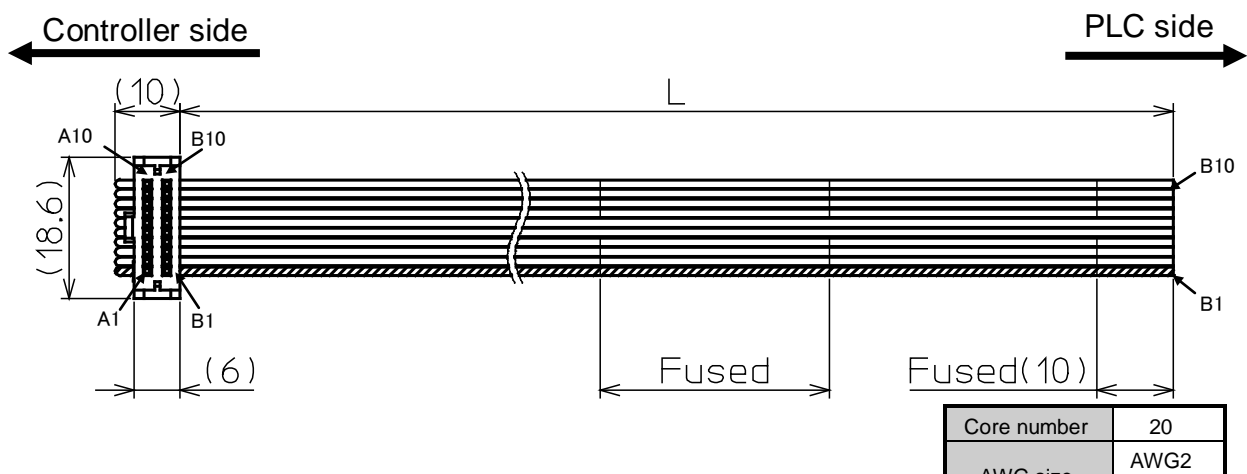

13.2 Controller setting kit

(1) How to Order Controller setting kit

L A T C - W 1

● Controller setting kit



Controller setting software



Controller setting cable

(2) Contents of the kit

- (i) Controller setting software (CD-ROM)
- (ii) Controller setting cable
(Communication cable, Conversion unit, USB cable)

(3) Operating environment

PC with WindowsXP or Windows7 and USB1.1 or USB2.0 port.

Windows[®], WindowsXP[®], and Windows7[®] are registered trademarks of the United States Microsoft Corporation.

* An operation test of this controller and setting software can be performed by using only the controller and the setting software under the following minimum requirements: [CPU speed 1.46 GHz, 512 MB RAM, Windows XP Professional Service Pack 3 operating system], and [CPU speed 2.53 GHz, 2 GB RAM, Windows 7 Professional operating system]. Depending on the specifications of the used computer and operating conditions, the Card Motor may not operate in accordance with the set time, even if the test operation time is set to minimum.

13.3. Multi-counter CEU5

Please refer to the operation manual of the CEU5 series Multi-counter for details.

(1) How to Order Multi-counter

C E U 5 □ □ - □

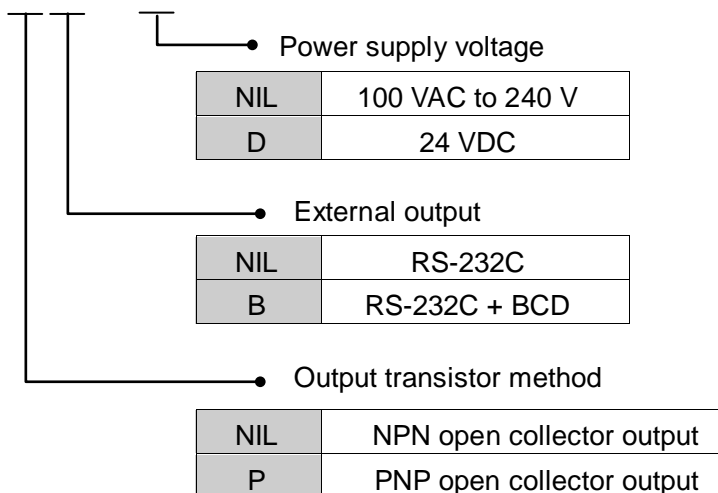

(2) Wiring

Connect wires in accordance with the instructions in chapter **“6. CN4: Counter plug” (P.21)**.

(3) How to use

When executing Step data No. 0 (Return to Origin Position), the reset signal is output from the controller after [Return to Origin Position] is completed. With this operation, CEU5 is reset and the position is set to zero.

When [Sensor Origin] is selected, the sensor origin position is set to zero. When [extended end position] is set as the origin position, the position after full-stroke is set to zero. Therefore, add an offset by the counter position adjustment function as required.

When the origin position is set to [Retracted End Position] or [Extend End Position], the position approx. 0.3mm away from the table end is set to the origin position. If the position where the table comes into contact with the workpiece needs to be displayed as zero on the counter, please reset it with PLC etc. separately with the table bumped.

Caution

CEU5 Multi-counter parameter settings:

Switch the CEU5 Multi-counter to Function mode [FUNC.] and set the Pre-scale [PRESCL] parameters to match the connected Card Motor model according to the specifications in the table below.

	LAT3-□	LAT3F-□		
Encoder resolution (μm)	30	5	2.5	1.25 ^{Note 1)}
Connected model	MANUAL			
Multiplier factor	X4	X1	X2	X4
Value per 1 pulse	00.0300	00.0050	00.0025	0.00125
Decimal point position		**.*		*.*****
Input type	2PHASE			

Note 1) Since the CEU5 Multi-counter has a 6-digit display, the tens of digits will not be displayed when the resolution is set to 1.25.

The Multi-counter may lose pulses when a long counter cable is used or when the Card Motor travels at high speed.

Refer to the CEU5 Multi-counter operation manual for setting details.

14. Alarm detection

It is possible to check the type of the alarm by a combination of lighting-up and flashing of ALM and PWR LEDs.

When an alarm is generated, deactivate the alarm after troubleshooting and correcting the error with reference to chapter “**14.2 Alarms and countermeasures**” (P.67).

Alarms are divided into two types. One can be cleared by resetting SVON input signal reset (ON-OFF-ON). The other cannot be cleared unless the power supply control is turned off.

14.1 AlarmLED display

The controller uses LED display to distinguish the type of the alarm when an alarm is generated.

Content of alarm	LED		
	PWR	ALM	Flashing type
Memory error	Flashing	Flashing	Flashing alternately by 0.5 seconds
Temperature error	Flashing	Flashing	Flashing simultaneously by 0.5 seconds
Over current error	Flashing	ON	by 0.5 seconds
Parameter error	ON	Flashing	by 0.5 seconds
Return to origin position non-execution error	ON	ON	-

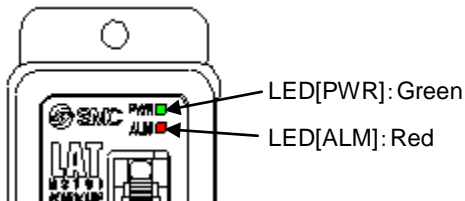

14.2 Alarms and countermeasures

Alarm name	Recovery method	Content / Countermeasure
Memory error	Turn the power off and on again.	<p><Content of error> The internal memory fails. Check if the conditions described below occurs.</p> <p>(1) Power supply shut-off during data writing (2) Power interruption of the power supply voltage (3) Noise due to crossing of cables and power lines.</p> <p><Countermeasure> Turn off the power and then turn it on again.</p>
Temperature error	Turn the power off and on again or reset using the SVON input.	<p><Content of error> The rated temperature is exceeded due to increase in temperature in the motor. Check if the conditions described below occurs.</p> <p>(1) The product is used in a location where the specified ambient temperature is exceeded. (2) There is a heat generating source around the motor. (3) The product is used with the force exceeding the allowable thrust setting value.</p> <p><Countermeasure> Review the ambient temperature and check the operation again after supplying power again or turning the SVON input signal OFF temporarily.</p> <div style="border: 1px solid black; padding: 5px; margin: 5px 0;"> <p style="text-align: center;"> Caution</p> <p>Please refer to the manual or the catalogue of the actuator for the allowable thrust setting value. When the Card Motor is not connected to the controller, temperature error can be generated due to unstable temperature information. Check the Card Motor and controller connection.</p> </div>
Over current error (Motor overload error) (Over current error)	Turn the power off and on again or reset using the SVON input.	<p><Content of error> This alarm is generated when the Card Motor has been overloaded causing an overcurrent to flow through the Card Motor, and when overcurrent flows through the parallel output terminals. Check if the conditions described below occur.</p> <p>(1) The motor cannot reach the target position during positioning due to obstacles. (2) The connection of the output signal is not correct.</p> <p><Countermeasure> Check the motor type and rated value. Turn the power off and on again Check the operation again after turning the SVON input signal OFF.</p>
Parameter error (Origin parameter error) (Step Data parameter error) (Invalid parameter error)	Turn the power off and on again or reset using the SVON input.	<p><Content of error> The basic parameter setup and step data setup settings are not correct. Check if any of the conditions described below occur.</p> <p>(1) Error related to the basic parameter data - [Card Motor product number] has not been selected. (2) Error related to the step data - "Target Position" of the step data is set outside of the stroke range, or the "positioning time", "speed", "acceleration" or "deceleration" is set to 0. - It is not possible to achieve the [Target position] and [Positioning time] using the Cycle Time Entry Method (or "Speed", "Acceleration" or "Deceleration" using the Speed Entry Method) for the next step data from the current table position.</p> <p><Countermeasure> Check the basic parameter data and step data. Check the operation again after turning off and on the power supply or turning the SVON input signal OFF.</p>
Return to origin position non-execution error	Turn the power off and on again or reset using the SVON input.	<p><Content of error> The operation is instructed while return to origin position has not been executed yet.</p> <p><Countermeasure> Perform the return to origin position after turning the SVON input signal OFF.</p>

15. Controller and Peripheral Devices / Specific Product Precautions

15.1 Design and selection

Warning

1. Use the specified voltage.

Otherwise, malfunction and breakage of the controller may result.

If the applied voltage is lower than the specified voltage, it is possible that the load cannot be moved due to an internal voltage drop. Please check the operating voltage before use. If the current is small, it may not be able to achieve the maximum force or cause a malfunction.

2. Do not operate beyond the specifications.

Fire, malfunction, or damage to the product can result. Please check the specifications before use.

3. Install an emergency stop circuit.

Please install an emergency stop outside of the enclosure so that it can stop the system operation immediately and intercept the power supply.

4. In order to prevent danger and damage due to the breakdown and the malfunction of this product, which may occur at a certain probability, a backup system should be established in advance by giving a multiple-layered structure or a fail-safe design to the equipment, etc.

5. If a fire or personal injury is expected due to abnormal heat generation, ignition, smoking of the product, etc, cut off the power supply for this product and the system immediately.

15.2 Handling Precautions

Warning

1. Never touch the inside of the controller/driver.

It may cause an electric shock or damage to the controller.

2. Do not perform the operation or setting of this equipment with wet hands.

It may cause an electric shock.

3. A product that is damaged or missing any components should not be used.

Electric shock, fire, and injury can result.

4. Do not connect the controller to actuators other than the Card Motor.

It may cause damage to the controller or the actuator.

5. Be careful not to be caught or hit by the workpiece while the actuator is moving.

It may cause an injury.

6. Do not connect the power supply or power on the product until it is confirmed that the area where the workpiece moves is safe.

The movement of the workpiece may cause an accident.

7. Do not touch the product when it is energized and for some time after power has been disconnected, as it is very hot.

It may cause burns due to the high temperature.

8. Check the voltage using a tester at least 5 minutes after power-off when performing installation, wiring and maintenance.

Electric shock, fire, and injury can result.

9. Incorrect wiring can cause malfunction or break the product. Do not touch the controller while power is supplied to it.

Take safety measures against static electricity sufficiently when it is necessary to touch the controller for maintenance.

⚠ Caution

1. When the multi-counter is not used, mount the counter plug attached to the counter connector.

If foreign matter such as metal fragments enters the counter connector, short-circuit may occur.

2. Be sure to perform return to origin position before using the product.

If the origin position is not set, the product will not operate even if the step data is selected.

3. The positioning time set and entered in the controller setting software is just the target value for operation. This is not guaranteed.

The operation may not complete even if the set positioning time has passed. In such a case, detect that the operation has completed with BUSY and INP signal.

4. Select the value approximated to the weight of jigs or workpieces mounted on the Card Motor as the load mass of the controller setting software.

If the value selected in the controller setting software and weight of workpieces are different, the product may vibrate or positioning accuracy may decrease.

5. When the load mounted on the Card Motor is small (such as 100 g or less) and the Card Motor has stopped at a target position, depending on the operating conditions the Card Motor may continuously hunt for the target position (vibrate) within the positioning accuracy range.

Please contact an SMC Sales representative for how to improve it.

6. BUSY output signal

The BUSY signal turns ON when the Card Motor begins to operate, and it turns OFF when the operating speed reaches 2 mm/s or less.

However, when the Card Motor operates at a slower speed than 5 mm/s, the BUSY signal may not turn ON at all.

7. INP output signal

Both in the positioning operation and pushing operation, if the specified positioning width set to the target position is reached, the signal will turn on.

In the pushing operation, if the table exceeds the target position and stays out of the specified positioning width, the signal will turn off.

INP signal output range

Model	Output range (mm)
LAT3F-*	+/-0.05
LAT3-*	+/-0.3

15.3 Installation

Warning

- 1. The controller and its peripheral devices should be installed on a fire-proof material.**
Direct installation on or near a flammable material may cause fire.
- 2. Do not install this product in a place subject to vibration and impact.**
A failure and malfunction can result.
- 3. Do not mount this controller and its peripheral devices together with large electromagnetic contactor or no-fuse breaker which generates vibration on the same panel. Mount them on different panels, or keep the controller and its peripheral devices away from such a vibration supply.**
A failure and malfunction can result.
- 4. This controller and its peripheral devices should be installed on a flat surface.**
If the mounting surface is distorted or not flat, excessive force may be applied to the housing, etc. causing malfunction.

15.4 Power supply

Warning

- 1. Use a power supply that has low noise between lines and between power and ground.**
In cases where noise is high, connect an isolation transformer.
- 2. The power supplies should be separated between the controller power and the I/O signal power and both of them do not use the power supply of “rush-current restraining type”.**
If the power supply is “inrush-current restraining type”, a voltage drop may be caused during the acceleration of the actuator.
- 3. Take appropriate measures to prevent surges from lightning. Ground the surge absorber for lightning separately from the grounding of the controller and its peripheral devices.**
- 4. Use the UL-certified products below for direct current power supply.**
 - a) Limited voltage current circuit in accordance with UL 508.
A circuit which power is supplied by secondary coil of a insulated transformer that meets the following conditions
 - Maximum voltage (No load): 30 Vrms (42.4 V peak) or less
 - Maximum current: 8 A or less (including short circuit)limited by circuit protector (such as fuse) with the following ratings

Voltage without load (V peak)	Maximum current rating (A)
0 to 20 [V]	5.0
Over 20 [V] up to 30 [V]	100 Peak voltage
 - b) Circuit (class 2) with maximum 30 Vrms (42.4 V peak) or less, which uses class 2 power supply unit in accordance with UL1310 or class 2 transformer in accordance with UL 1585 as the power supply

15.5 Grounding

Warning

- 1. Make sure the product is grounded to ensure the noise tolerance of the controller.**
Otherwise it may cause malfunction, damage, an electric shock or fire.
Do not share the earth with equipment that generates a strong electromagnetic noise.

2. Dedicated grounding should be used.

Grounding should be to a D-class ground. (Ground resistance 100Ω or less)

3. Grounding should be performed near the unit as much as possible to shorten the grounding distance.

4. In the unlikely event that malfunction is caused by the ground, it may be disconnected.

15.6 Wiring

 **Warning**

1. Preparation for wiring

Switch the power supply off before wiring or plugging and unplugging of connectors.

Mount a protective cover over the terminals after the wires have been connected.

2. Do not route the digital I/O signal wires and power supply cables together.

Malfunctions stemming from noise may occur if the digital I/O signal and power cables are routed together.

3. Confirm proper wiring before switching the power on.

Incorrect wiring will lead to malfunction or may damage the controller or its peripheral devices depending on the seriousness of the wiring error.

Confirm that there is no mis-wiring before switching the power on.

4. Reserve enough space for the routing of the cables.

If the cables are forced into unreasonable positions, it may damage the cables and connectors, which may lead to misconnection or short-circuit and result in malfunction.

Avoid bending the cables in sharp angles close to the connectors or where they enter the product.

Fix the cable as close as possible to the connectors so that mechanical stress cannot be applied to the connectors.

15.7 Operating environment

 **Caution**

1. Do not use in an area where dust, powder dust, water or oil is in the air.

A failure and malfunction can result.

2. Do not use in an area where a magnetic field is generated.

It will cause failure or malfunction.

3. Do not install in the environment of flammable gas, explosive gas and corrosive gas.

It could lead to fire, explosion and corrosion.

4. Avoid radiating heat from large heat sources such as direct sunlight or heat treating furnace

It will cause failure of the controller or its peripheral devices.

5. Do not use the product in an environment subject to a temperature cycle.

It will cause failure of the controller or its peripheral devices.

6. Do not use in a place where surges are generated.

When there are units that generate a large amount of surge around the product (Ex. solenoid type lifters, high frequency induction furnaces, motors, etc.), this may cause deterioration or damage to the product's internal circuit. Avoid surge generation and crossed lines.

7. Neither the Card Motor nor the controllers have the tolerance to the thunder surge.

8. Do not install this product in an environment subject to vibration and impact.

It will cause failure or malfunction.

9. If this product is used with a relay or solenoid valve, they should be the surge absorbing element built-in type.

10. Do not expose the product to a strong light source such as direct sunlight.

The Card Motor uses an optical sensor to detect the position, so if it is exposed to a strong light source such as direct sunlight, a malfunction could occur. In such a case, install a light shielding plate such as a cover.

15.8 Maintenance

 **Warning**

1. Perform maintenance checks periodically.

Confirm wiring and screws are not loose.

Loose screws or wires may cause unexpected malfunction.

2. Conduct an appropriate functional inspection after completing the maintenance.

In case of any abnormalities (if the actuator does not move, etc.), stop the operation of the system.

Otherwise, an unexpected malfunction may occur and it will become impossible to ensure safety.

Give an emergency stop instruction to confirm safety.

3. Do not disassemble, modify or repair this controller and the peripheral equipment.

4. Do not put anything conductive or flammable inside of this controller.

Burning or explosion can result.

5. Do not perform the insulation resistance test or insulation withstand voltage test.

 **Caution**

1. Ensure sufficient space for maintenance.

Design the system that allows required space for maintenance.

16. Troubleshooting

Refer to the table below for troubleshooting.

When none of the causes in the troubleshooting can be confirmed, it is presumed that the product is faulty and normal operation can only be recovered by the replacement of a part.

There is a possibility that this product has been damaged due to the operating conditions (problems relating to the application), so please contact SMC to discuss appropriate measures.

16.1 Operation troubles

Error Problem	Error Possible causes	Investigation method and the location of possible causes	Countermeasures
Does not operate at all.	Power supply failure.	Is the green LED in the controller lit?	Check the supplied voltage and current for power supply to the controller. → 4. External Wiring Diagram (P.17) → 5. CN1: Power supply plug (P.19)
	External equipment failure	PLC connected to the controller operates properly? Check the operation of the controller itself by test operation, which is a function of the setting software.	Refer to the operation manual of the controller and take appropriate measures. → 7.3 The parallel I/O signal (P.24)
	Incorrect wiring	Check if the wiring is correct. Refer to the operation manual of the controller to check wiring, for broken wires and short-circuits.	Correct wiring and check if the input/output of each signal is correct. Separate the power supply for the CN1 controller power supply and the CN5 I/O signal power supply. → 4. External connection (P.17) → 7.4 Parallel I/O connector wiring (Example) (P.28)
	Alarm generated	Controller alarm is generated? Refer to the operation manual of the controller. Check the type of alarm.	Refer to the operation manual of the controller and take appropriate measures. → 14. Alarm Detection (P.66)
	Unsuitable specification	Check that the Basic Parameter Setup settings in the controller (product number and mounting orientation of the Card Motor) correspond to the product number and mounting orientation of the Card Motor that is connected to the controller.	Set the product number and mounting orientation of the connected Card Motor to the controller. → 12.2 Basic Parameter Setup window (P.51)
	Duplicated operation commands	The parallel I/O signals are activated in "Test Mode" whilst the Controller Setting Software is being started.	Select "Monitor Mode" in the Monitor/Test window of the Controller Setting Software, or terminate the setting software. → 11.1 Overview of the operation instructions (P.46) → 12.4 Monitor/Test window (P.57)
	Signal timing	The parallel I/O signals have been activated after the power supply has been turned on and before the ALARM output has turned ON. The DRIVE signal is turned OFF during operation (except when the Card Motor is performing a pushing operation).	Activate the parallel I/O signals first after that the ALARM signal has been activated after the power supply has been turned on. If the DRIVE signal is turned OFF during operation, the table of the Card Motor stops on the spot, and holds the position. If it is required to complete the operation, do not turn OFF the DRIVE signal until the operation has been completed. → 11.2 Parallel I/O operation procedures (P.46) → 7.3 Parallel I/O signal (P.24)

Operation stops intermittently	Alarm generated	Controller alarm is generated? Refer to the operation manual of the controller. Check the type of alarm.	Refer to the operation manual of the controller and take appropriate measures. → 14. Alarm Detection (P.66)
	Incorrect wiring	Check if the wiring is correct. Refer to the operation manual of the controller to reconfirm wiring, broken wires and short-circuits.	Correct wiring and check if the input / output of each signal are correct. Separate the power supply for the CN1 controller power supply and the CN5 I/O signal power supply. → 4. External connection (P.17) → 7.4 Parallel I/O connector wiring (Example) (P.28)
	Noise	Ground properly. Avoid bundling the cables.	Refer to the operation manual of the controller and take appropriate measures. → 3.4 Mounting (P.15)
	Parameter wrong input	Check if parameter values are correct. Reconfirm if appropriate controller is used for the actuator.	Modify the parameters to appropriate ones and test the operation. → 8. Setting Data Entry (P.29)
	Voltage drop	Temporary voltage drop in the power supply.	Possibility of momentary voltage drop due to an inadequate power supply capacity is inadequate, or the power supply is inrush current suppressor type. → 3. Product Specifications (P.12)
	Unsuitable specification	Check that the Basic Parameter Setup settings in the controller (product number and mounting orientation of the Card Motor) correspond to the product number and mounting orientation of the Card Motor that is connected to the controller.	Set the product number and mounting orientation of the connected Card Motor to the controller. → 12.2 Basic Parameter Setup window (P.51)
	Signal timing	Check the timing of the signal from the PLC to the controller.	PLC processing delay and controller scan delay are generated. Please ensure an interval of 2msec or more between input signals, and maintain the signal state. → 9.5 Controller input signal response time (P.41)
	Setting error	The "Operating Time" in the "Continuous Operation (Test of the continuous operation)" menu in the Controller Setting Software is set to be too short.	Modify the "Operating Time" settings. → 12.4 Monitor/Test window (P.57)
The Card Motor vibrates.	Unsuitable specification	Check that the Basic Parameter Setup settings in the controller (product number and mounting orientation of the Card Motor) correspond to the product number and mounting orientation of the Card Motor that is connected to the controller.	Set the product number and mounting orientation of the connected Card Motor to the controller. → 12.2 Basic Parameter Setup window (P.51)
	Inappropriate parameter input	Check that the parameter values are appropriate and that the program is correct. Check and confirm that the target position, positioning time and load mass values are correct.	Amend the parameters by modifying the Step Data settings. Set the "Load Mass" value as close as possible to the weight of the workpiece mounted on the Card Motor. If the Card Motor still vibrates reduce the "Load Mass" value. After the possible causes are eliminated switch off the power supply once and switch it on again. Modify the parameters to the appropriate ones and test the operation. → 8.2 Step Data Setup setting method and movement profiles (P.30) → 8.3 Step Data setup (P.33)
	The Card Motor or the workpiece is loose	Check if something has come loose and confirm that the Card Motor is fixed properly to the mounting frame, and that the workpiece is fixed properly to the Card Motor table.	Tighten the Card Motor and the workpiece securely. Refer to the LAT3 Card Motor Operation Manual for details of tightening torques and how to fix them.

Communication with the controller cannot be established. (LATC-W1)	The USB driver is not installed	Check that the USB driver for the conversion unit is installed.	<p>If the USB driver has not been installed, the installation of the USB driver starts automatically when the conversion unit is connected to the PC.</p> <p>For details of the installation procedure refer to the "LATC-W1 Controller Setting Software Installation Manual".</p> <p>* The USB driver needs to be installed individually for every COM port.</p> <p>* If the installation does not start when the conversion unit is connected to the PC, the USB driver may have already been installed. A specific COM port number is assigned to each COM port the conversion unit is connected to. Check that the COM port number match with the COM port the conversion unit connected to.</p> <p>The COM port number can be checked using the Device Manager of the PC. For details of the COM port checking method refer to the "LATC-W1 Controller Setting Software Installation Manual".</p>
	Incorrect COM port setting	Check that the correct COM port is set to the Controller Setting Software.	<p>The COM port allocated to the conversion unit is different for different PC's. Check and confirm the COM port number with the conversion unit connected to the PC. The COM port number can be checked using the Device Manager in the PC. For details of the COM port checking and setting methods refer to the "LATC-W1 Controller Setting Software Installation Manual".</p>
	Connection failure	Confirm the connection status.	<p>Confirm that the LATC4 controller communication cable, conversion unit, USB cable, and PC are connected correctly. For example, communication cannot be established if the connector has been damaged.</p> <p>Check that the power supply to the controller (LATC4) has been turned on. Communication cannot be established if the power supply is off.</p> <p>If any external equipment (PLC and measurement hardware), except the LATC4 controller, are connected to the PC, disconnect them. (There is a possibility that the other equipment connected to the PC interfere with the communication.)</p>
	The CPU of the PC is busy or overloaded	Confirm that no other applications except the Card Motor Controller Setting Software are running simultaneously, and that the CPU of the computer is not overloaded.	<p>Terminate all other applications except the Card Motor Controller Setting Software.</p>

16.2 Position / Speed troubles

Error Problem	Error Possible causes	Investigation method and the location of possible causes	Countermeasures
Displacement	Displaced from the origin position	In case of return to origin position on the pushing or retracting end position, does the actuator travel to the origin position? Perform return to origin position several times to check the origin position.	Check actuator's operation (if foreign matter is caught in the product etc.).
	Inappropriate parameter input	Check if the values for the parameter are appropriate and the program is correct. Reconfirm the target position, positioning time and load mass.	Modify the parameters to appropriate ones and test the operation. → 8. Setting Data input (P.29)
	Unsuitable specification	Check that the Basic Parameter Setup settings in the controller (product number and mounting orientation of the Card Motor) correspond to the product number and mounting orientation of the Card Motor that is connected to the controller.	Set the product number and mounting orientation of the Card Motor to the controller. → 12.2 Basic Parameter Setup window (P.51)
	Use in a strong light source.	Check that the Card Motor is not exposed to a strong light source such as direct sunlight.	Install a light shielding plate as a cover.
	Signal timing	The Card Motor has been commanded to execute a new relative step data whilst the table of the Card Motor was still moving. A relative positioning has been performed from a position with remained deviation.	In relative positioning the table moves the set travel distance from the current table position. Therefore ensure that the initial table starting position is where the table is supposed to be before starting relative positioning. → 8.2 Step Data Setup setting method and movement profiles (P.32)
Doesn't move to the correct position	Incorrect wiring	Check if the wiring is correct. Refer to the operation manual of the controller to check wiring, broken wires and short-circuits.	Correct wiring and check if the input/output of each signal is correct. Separate the power supply for the CN1 controller power supply and the CN5 I/O signal power supply. → 4. External connection (P.17) → 7.4 Parallel I/O connector wiring (Example) (P.28)
	Unsuitable specification	Check that the Basic Parameter Setup settings in the controller (product number and mounting orientation of the Card Motor) correspond to the product number and mounting orientation of the Card Motor that is connected to the controller.	Set the product number and mounting orientation of the Card Motor to the controller. → 12.2 Basic Parameter Setup window (P.51)
	Signal timing	Check the timing of the signals from the PLC to the controller. The DRIVE signal is turned OFF whilst a step data is being executed.	PLC processing and controller scan delay times are generated. Ensure an interval of 2 msec or more between input signals, and maintain the signal state for at least 2 msec. When the DRIVE signal is turned OFF, the table of the Card Motor stops on the spot, and holds the position. If it is required that the operation is completed, do not turn OFF the DRIVE signal until the operation has been completed. → 9.5 Response time for the controller input signals (P.41) → 7.3 Parallel I/O signals (P.24)

Doesn't move to the correct position	Data writing failure	Check whether data (step data, parameter) is written correctly. Do not turn off the controller input power or remove the cable while data is being written.	Turn the power OFF and ON again. Re- input correct data (step data, parameter) again and confirm operation. → 3.2 Parts description (P.13) → 8. Setting Data Entry (P.29)
Speed does not reach the desired speed.	Inappropriate parameters	Check if parameter values are correct. Reconfirm the target position, positioning time and load mass.	Modify the parameters to appropriate ones and test the operation. → 8. Setting Data Entry (P.29)
	Operation pattern is not suitable.	Check that appropriate positioning time and load mass is entered based on the current and target position.	Shorten the positioning time or increase the load mass. → 8. Setting Data Entry (P.29)
	Unsuitable specification	Check that the Basic Parameter Setup settings in the controller (product number and mounting orientation of the Card Motor) correspond to the product number and mounting orientation of the Card Motor that is connected to the controller.	Set the product number and mounting orientation of the Card Motor to the controller. → 12.2 Basic Parameter Setup window (P.51)
	Voltage drop	Temporary voltage drop in the power supply.	Possibility of momentary voltage drop due to an inadequate power supply capacity is inadequate, or the power supply is inrush current suppressor type. → 3. Product Specifications (P.12)
Pushing thrust does not reach the thrust setting value.	Inappropriate parameters	Check that the parameter values are set correctly for a pushing operation Step Data.	Set the maximum speed to be 1 mm/s or more for pushing operation. Modify all other parameters to appropriate ones and test the operation. → 8. Setting Data Entry (P.29) → 9.3 Pushing operation (page 39)
	Unsuitable specification	Check that the Basic Parameter Setup settings in the controller (product number and mounting orientation of the Card Motor) correspond to the product number and mounting orientation of the Card Motor that is connected to the controller.	Set the product number and mounting orientation of the Card Motor to the controller. → 12.2 Basic Parameter Setup window (P.51)
	Voltage drop	Temporary voltage drop in the power supply.	Possibility of momentary voltage drop due to an inadequate power supply capacity is inadequate, or the power supply is inrush current suppressor type. → 3. Product Specifications (P.12)

Revision history
A: Complete revision Revised in September 2012

SMC Corporation

4-14-1, Sotokanda, Chiyoda-ku, Tokyo 101-0021 JAPAN

Tel: + 81 3 5207 8249 Fax: +81 3 5298 5362

URL <http://www.smcworld.com>

Note: Specifications are subject to change without prior notice and any obligation on the part of the manufacturer.

© 2010-2012 SMC Corporation All Rights Reserved

